

# FATIGUE ANALYSIS OF DOUBLE CHANNEL COLD FORMED STEEL BEAM COLUMN JOINT

Rakshith S L<sup>1</sup>, Nisarg Shankar S<sup>2</sup>, Dr.Puttaraju<sup>3</sup>

<sup>1</sup>P.G. Student, Civil Engineering Department, S J B Institute of Technology, Bengaluru - 560060, Karnataka, India

<sup>2</sup>Assistant Professor, Civil Engineering Department, S J B Institute of Technology, Bengaluru - 560060, Karnataka, India

<sup>3</sup>Principal, Civil Engineering Department, S J B Institute of Technology, Bengaluru-560060, Karnataka, India

\*\*\*

**Abstract** - In steel construction, cold-formed structural members are becoming more popular and have a increasing importance. Its growing popularity in building construction is due to its advantages over other construction materials such as lightness and consequent ease of erection and installation, economy in transportation and handling. Even though the static behaviour of cold-formed steel elements is well established, fatigue behaviour of these elements under fluctuating loads is still uncertain. Fatigue strength is important for cold-formed steel structural members and the probability of failure by fatigue is comparable with that of other Ultimate Limit State modes of failure. Hence the prospect of using cold-formed steel sections under dynamic conditions becomes attractive. Objective of this study is to examine the performance of cold formed steel beam column joint subjected to fatigue loading. Using ANSYS software, fatigue analysis of double channel beam column - joint with a bolted and a welded connection with varying thickness (3mm and 5mm) are planned to be studied. Within bolted connection, bolts only and cleat angle connections are studied. From this study, the best connection is flange and web cleat bolted connection.

**Key Words:** Ansys, Fatigue, Cold formed steel, welded connections, Bolted Connections.

## 1. INTRODUCTION

Fatigue is a process that causes failure or damage to the element subjected to repeated loading. Fatigue occurs when a member subjected to a repeated cyclic loading. The process fatigue occurrence appears in type of cracks creating at the specific areas in the construction. Fatigue is the procedure of dynamic restricted long-term basic change happening in a member subjected to circumstances that deliver fluctuating stress and strain sooner or later (or focuses) and it finishes up in cracks or rupture after an adequate amount of variances. The invention of the fatigue happened in 1800s when various investigators in Europe watched the bridges, railroad segments are cracked under the repetitive loading. As far the century continued and utilization of metals reached out in increasing the utilization of the machines, an ever increasing number of disasters of parts exposed to repetitive loadings were documented. In mid-1800s, a scientist named A.Wohler suggested a technique in which

the disaster of segments from repetitive loadings could be moderated and, now and again, rejected. Undoubtedly, previous disasters from the repetitive loads had brought about disasters of parts, for example, concrete buildings, wooden structures, however the necessity for extra machines produced using metal segments in late 1800s invigorated the requirement to create outline techniques that will keep disasters from repetitive loads of a wide range of hardware. This action then concentrated from the mid of 1800s is as yet in progress today. These must be utilized as a part of a predictable outline movement that might be alluded to as an exhaustion plan strategy. Clearly, if other time related disappointment methods happen associatively with repetitive loads and it collaborates generally, at that point the assignment turns out to be much all the more difficult. As much as people dependably want to utilize more products and placed more requests on the things they could plan and deliver, the test of fatigue was continually going with us. Until the early piece of 1900s, not an extraordinary arrangement was thought about the physical wellspring of fatigue. However, with the appearance of an expanded comprehension of materials, which quickened in the mid-1900s, a lot of information has been produced about repeated load effects on engineering materials. The fatigue procedure has ended up being exceptionally hard to consider. In any case, broad advance on understanding the stages of fatigue has been made over the most recent 100 years or somewhere in the locality.

## 2. OBJECTIVES

- To determine the fatigue behaviour of double channel cold formed steel beam column joint subjected to fatigue loading.
- To determine the fatigue life of double channel cold formed steel beam column joint with varying thickness.
- To determine the best connection of double channel cold formed steel beam column joint in both thickness.

### 3. STAGES INVOLVED IN FINITE ELEMENT MODELLING

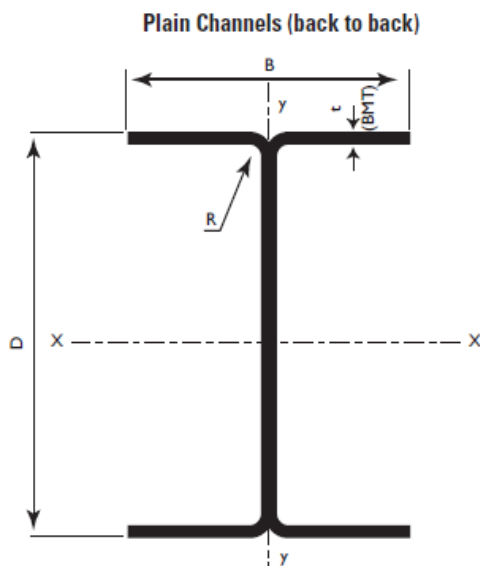
#### 3.1 Engineering Data

The material properties of cold formed steel section are explained here,

Young 'Modulus	250GPa
Poisson's ratio	0.3
Yield Strength	350MPa

#### 3.2 Geometry

The sectional data of cold formed steel column beam joint are showed below. Double channel section with length of the column as 1500mm and length of the beam as 1000mm with the varying thickness of 3mm and 5mm.

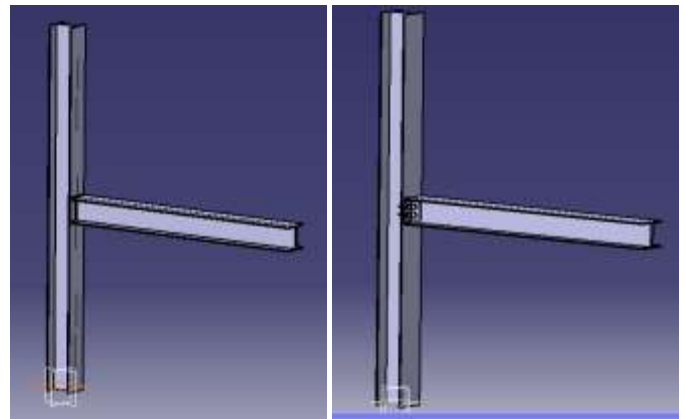


D=100mm, B=100mm, t=3mm & 5mm

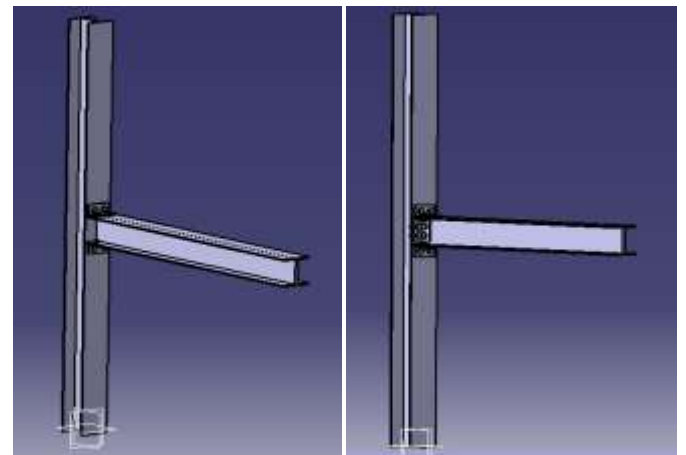
**Fig-1:** Details of Double channel section

#### 3.3 MODELLING

Four models with different connection such as welded connection, bolted connection with web cleat angle connection, flange cleat angle connection, web and flange cleat angle connection with variation in thickness 3mm and 5mm are designed using CATIA software.



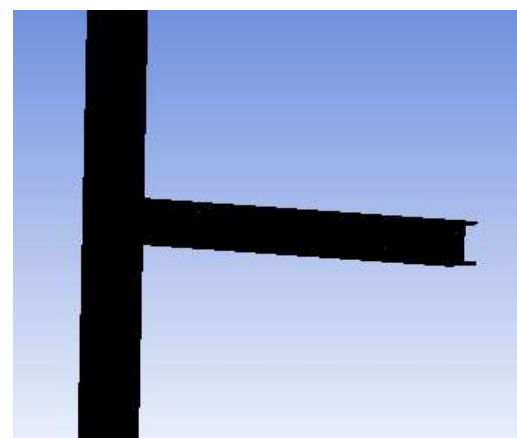
**Fig -2:** DC-WW(3 and 5mm) **Fig-3:** DC-FC (3 and 5mm)



**Fig-4:** DC-FC (3and 5mm) **Fig-5:** DC-FWC-(3 and 5mm)

#### 3.4 MESHING

The model has been divided into Finite number of elements called Mesh. The meshing has been provided of 5mm for all types of connections.



**Fig -6:** Meshed joint

### 3.5 SETUP

In this case load and boundary conditions are applied to the ansys model. Here the support condition is fixed at both the ends of the column and load is provided in a region which is 1m from the free end of beam

### 4. RESULTS AND DISCUSSION

By applying fatigue analysis on beam column joint different values such as load, deformation, fatigue life and damage are obtained for varying thickness. The results are shown below.

1. Double channel beam column joint of welded connection with thickness 3mm and 5mm are analyzed and the results are presented below.

2. Double channel beam column joint with web cleat bolted connection with thickness 3mm and 5mm are analyzed and the results are presented below.

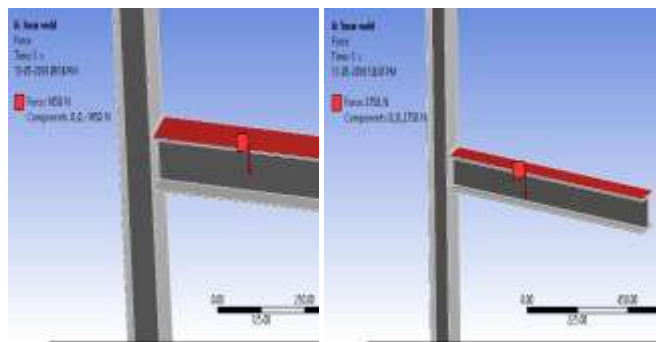


Fig -7: Load taken by 3mm and 5mm section

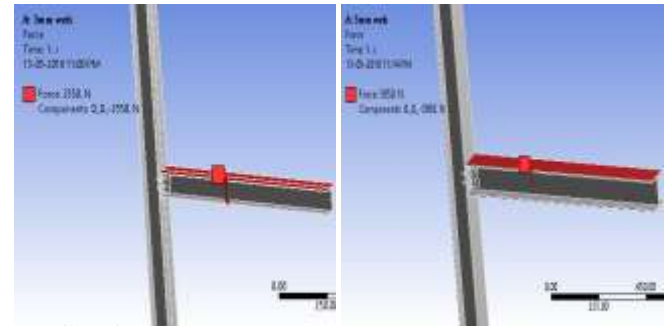


Fig -10: Load taken by 3mm and 5mm section

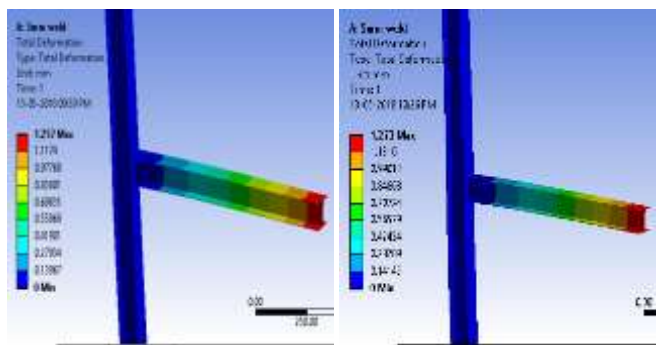


Fig -8: Deformation of 3mm and 5mm section

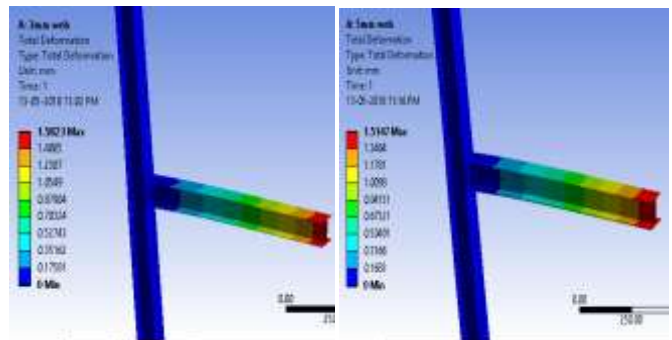


Fig -11: Deformation of 3mm and 5mm section

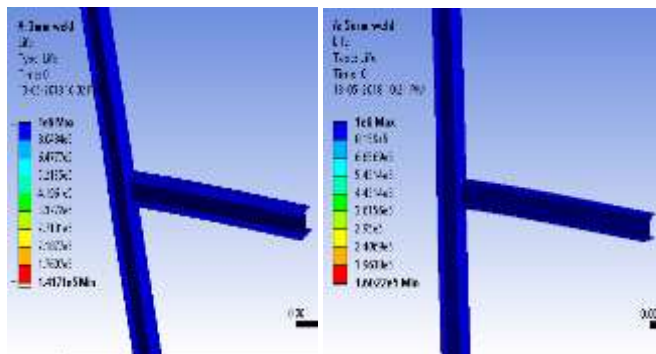


Fig -9: Fatigue life of 3mm and 5mm section

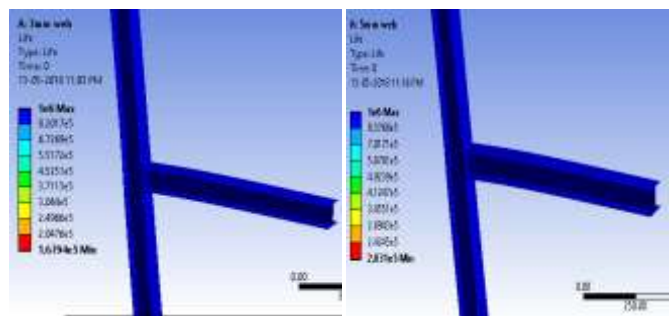


Fig -12: Fatigue life of 3mm and 5mm section

3. Double channel beam column joint with flange cleat bolted connection with thickness 3mm and 5mm are analyzed and the results are presented below.

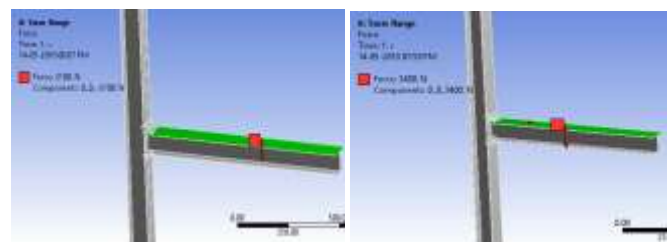


Fig -13: Load taken by 3mm and 5mm section

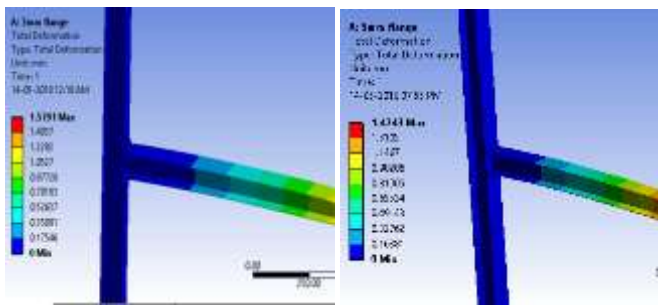


Fig -14: Deformation of 3mm and 5mm section

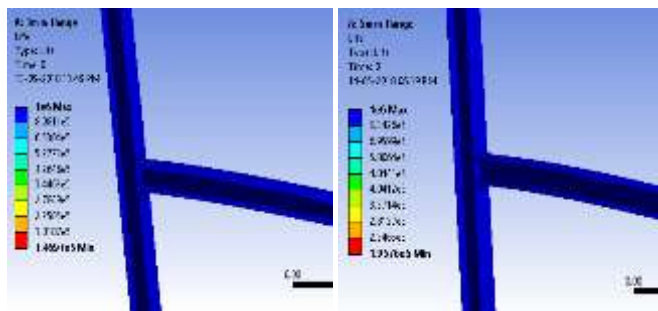


Fig -15: Fatigue life of 3mm and 5mm section

4. Double channel beam column joint with both web cleat and flange cleat bolted connection with thickness 3mm and 5mm are analyzed and the results are presented below.

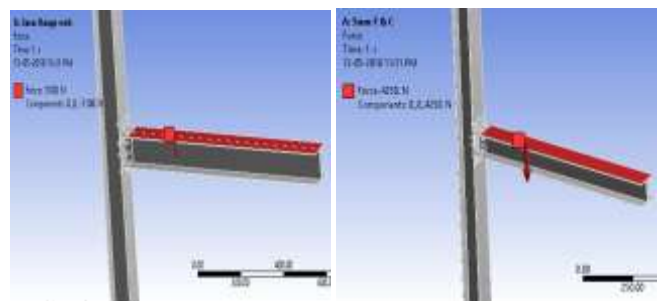


Fig -16: Load taken by 3mm and 5mm section

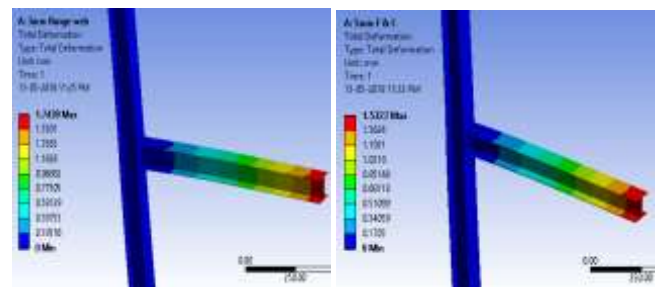


Fig -17: Deformation of 3mm and 5mm section

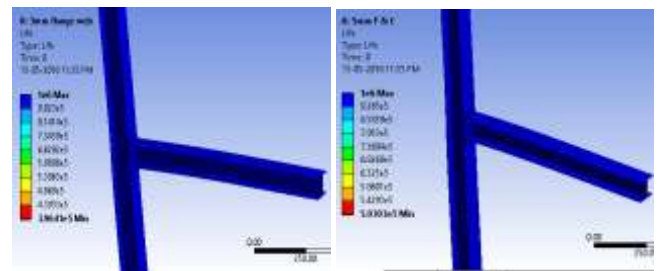


Fig -18: Fatigue life of 3mm and 5mm section

5. Stress-Cycle curve (S-N curve) obtained for the given cold formed steel section is given below.

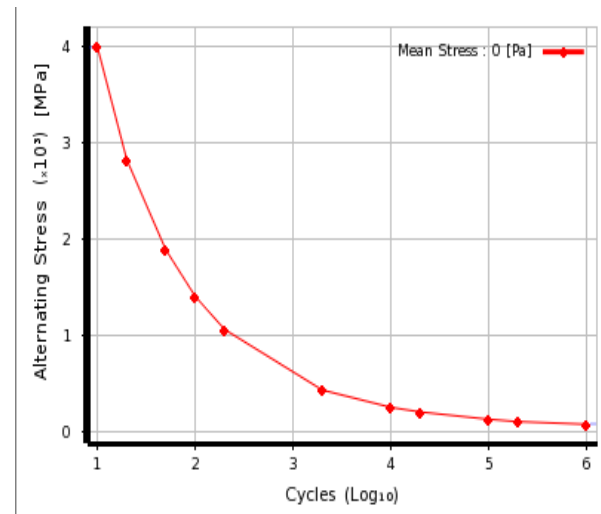
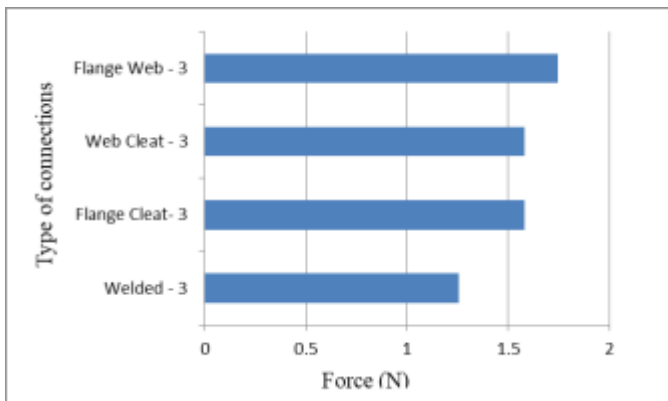


Chart-1 S-N Curve for Cold formed steel section

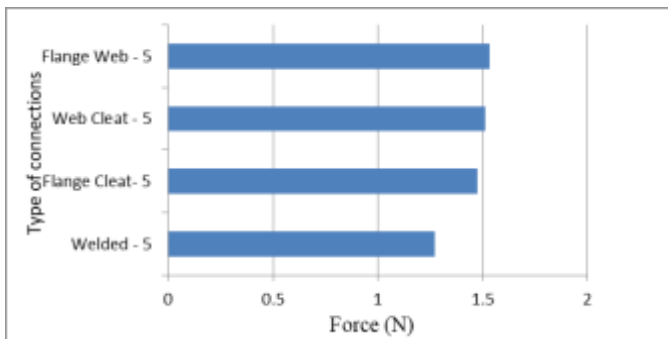
Table-1 Fatigue results of double channel section

Type of connection	Force (N)	Deformation (mm)	Life (cycles)
DC-WW-3	1650	1.257	1.417x10 <sup>5</sup>
DC-WW-5	2750	1.273	1.602x10 <sup>5</sup>
DC-FC-3	2550	1.5823	1.679x10 <sup>5</sup>
DC-FC-5	3850	1.5147	2.031x10 <sup>5</sup>
DC-WC-3	2100	15791	1.469x10 <sup>5</sup>
DC-WC-5	3400	1.4743	1.957x10 <sup>5</sup>
DC-FWC-3	3100	1.7439	3.9641x10 <sup>5</sup>
DC-FWC-5	4250	1.5327	5.0303x10 <sup>5</sup>

From the above following graphs are drawn and comparisons are made and listed below.

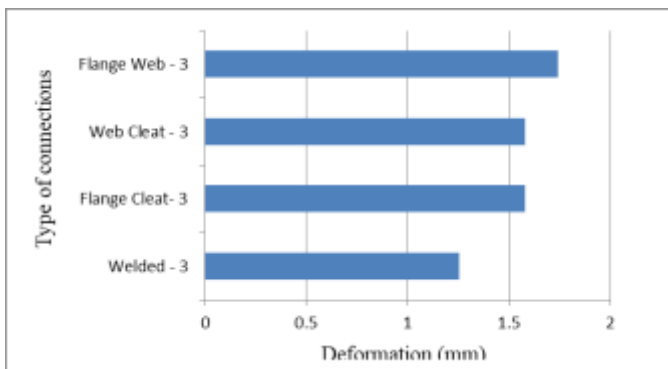


**Chart-2** Comparing the value of force in 3mm thick section

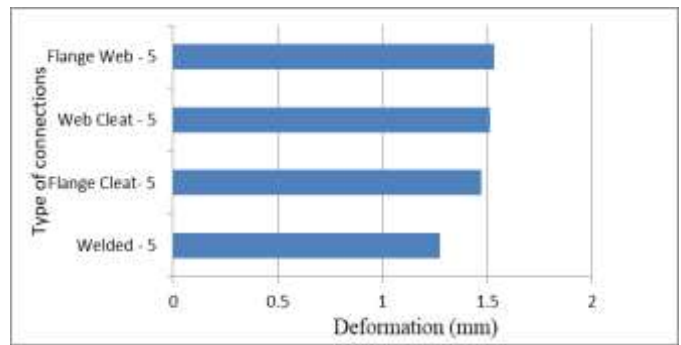


**Chart-3** Comparing the value of force in 5mm thick section

The force applied is different for different connections and the load applied is in ascending order from one connection to another. The force applied is maximum in flange web cleat bolted connection and less in welded connection for both 3mm and 5mm thickness section.

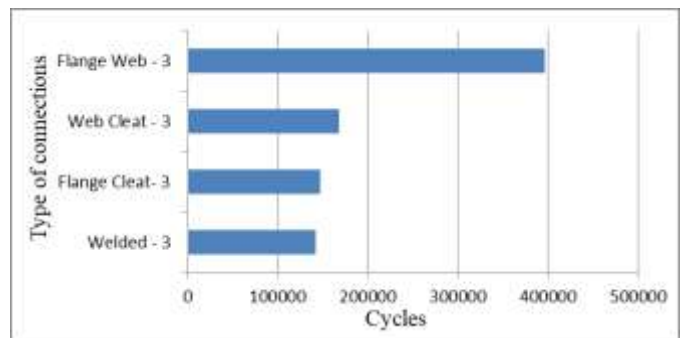


**Chart-4** Comparing the value of deflection in 3mm thick section.

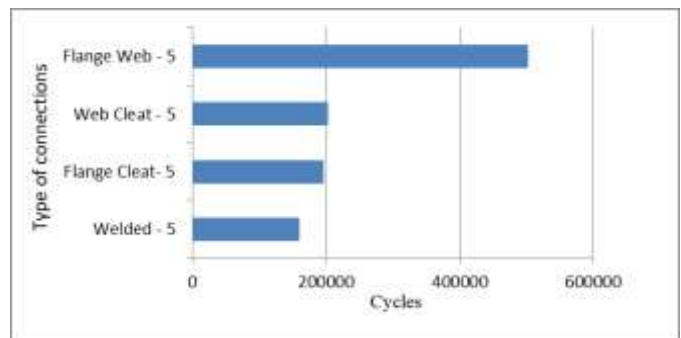


**Chart-5** Comparing the value of deflection in 5mm thick section.

Deflection has somewhat slight variation in all connections with variation in thickness.



**Chart-6** Comparing the number of cycles in 3mm thick section



**Chart-7** Comparing the number of cycles in 5mm thick section.

Maximum number of fatigue life is for flange and web bolted connection and minimum is for welded connection for both 3mm and 5mm thickness.

## 5. CONCLUSIONS

The main conclusions drawn from this study are summarized below:

1. The analysis type used in the study is stress life which is based on stress cycle curves.

2. The force equivalent to yield stress of the cold formed steel section is given as fatigue load for each of the connections.

3. The fatigue life defined in this study was between  $10^5$  to  $10^6$  cycles.

4. The endurance limit of cold formed steel section is 86.2MPa.

5. In the case of double channel section the maximum load is taken by flange and web cleat bolted connection i.e., 3100N for 3mm thickness and 4250N for 5mm thickness and minimum load of 1650N and 2750N for welded connection with 3mm and 5mm thickness.

6. Minimum fatigue life is for welded connection ( $1.4171 \times 10^5$  cycles) for 3mm thickness and ( $1.6022 \times 10^5$  cycles) for 5mm thickness.

7. Maximum fatigue life is for flange and web cleat bolted connection ( $3.9641 \times 10^5$  cycles) for 3mm thickness and ( $5.0303 \times 10^5$  cycles) for 5mm thickness.

#### ACKNOWLEDGEMENT

I am thankful to my guide, Asst.Professor, Nisarg Shankar Civil Engineering Department and my Principal Dr.Puttaraju for their constant encouragement and through guidance. I also thank my parents, friends and above all the god almighty for making this work complete.

#### REFERENCES

- [1] Amit M. Chavan, Dr.S.S.Angalekar "Finite element analysis of cold formed perforated beam column connections", International Research Journal of Engineering and Technology", Volume 03, July 2017, Issue 07, pp-ISSN 2395-0056.
- [2] B. A. Ali, S. Saad, M. H. Osman, Y. Ahmad "Finite Element Analysis of Cold-formed Steel Connections", International Journal of Engineering (IJE), Volume(5), issue (2) 2011.
- [3] Bayan Anwer Ali, Sariffuddin Saad, Mohd Hanim Osman & Yusof Ahmad, "Finite Element Analysis of Cold-formed Steel Connections" International Journal of Engineering (IJE), Volume (5): Issue (2): 2011, pp-185-192.
- [4] Blaz Cermelj, Primož Moze, Franc Sinur "On the prediction of low-cycle fatigue in steel welded beam-to-column joints", Journal of Constructional Steel Research, Volume 117, July 2015, pp.49-63.
- [5] Foster. P, Abdelal. G, Lim J. B. P, Hajsadeghi M, McCrum D "Journal of Construction in Developing countries", Volume 21(1), 2016, pp.167-180.
- [6] IS: 801-1975 Indian standard code of practice for use of cold-formed light gauge steel structural members in general building construction.
- [7] IS 811: Specification for cold formed light gauge structural steel sections.
- [8] Jia Wang , Brian Uy , Huu-Tai Thai , Dongxu Li "Behaviour and design of demountable beam-to-column composite bolted joints with extended end-plates", Journal of Constructional Steel Research, Volume 144, November 2017, pp.221-235.
- [9] Karthika G N, Pinky Merin Philip "Fatigue analysis of double channel cold formed steel beam column joint", International Research Journal of Engineering and Technology", Volume 04, Jan 2017, Issue 05, pp-ISSN 2395-0072.
- [10] Mahmood Md Tahir, Irwan Juki, Lee Hong Yong "Finite Element Analysis of Flush End-plate connections connected to Column Web", International journal of steel structures, Vol.11, No 3, September 2011, pp.247-258.
- [11] O.Mirza "Finite Element Analysis of the Behaviour of Composite Beam-to-Column connections subjected to seismic loading", Structures Congress ASCE, Volume 9, Issue 3, June 2014, pp.3346-3353.
- [12] Shubhangi P. Tippe, P.M. Kulkarni "Finite element analysis of perforated beam column connections", International Research Journal of Engineering and Technology", Volume 05, May 2017, Issue 01, pp-ISSN 2395-0072.
- [13] Yufan Huang , Enrico Mazzarolo , Bruno Briseghella , Tobia Zordan , Airong Chen "Experimental and numerical investigation of the cyclic behaviour of and innovative prefabricated beam-to-column joint", Engineering Structures, Volume 150, 2017, pp.373-389.