

Experimental Investigation on Flexural Behaviour of Corroded R.C Beam Retrofitted with Basalt Fiber Sheet

Prakash Bharvad¹, Abbas Jamani²

¹Student, Dept. of Structural Engineering, L.J Institute of engineering and technology, Ahmedabad

²Asst. Professor, Dept. of Structural Engineering, L.J Institute of engineering and technology, Ahmedabad

Abstract - The present study deals with the behaviour of beams having corroded reinforcements of varying levels of corrosion such as 5%, 10% and 15% mass loss in reinforcements and the effect of Basalt fiber sheet wrapping on its flexural behaviour. Total of 78 beam specimens will be casted which will consist of 6 control specimen. The control specimen will be of non-corroded reinforcements in group of 3 each for concrete grade of M-20 and M-25. 36 beam will be casted with M-20 grade of concrete. From 39 beam group of 3 beam for 5%, 10% and 15% corrosion reinforcement and its wrapping by 4 different techniques for same grade will be casted. Similar 39 beams for M25 grades will be casted. And result are compared with the normal specimen for flexural strength of the beam specimen. Basalt fiber retrofitting with U-wrapping Pattern improved the ultimate load carrying capacity and flexural Strength of corroded beams significantly high than other wrapping pattern.

Key Words: Retrofitting of beam, Corrosion of steel, load carrying capacity, Flexural strength, Basalt fiber, Wrapping Pattern. Etc.

1. INTRODUCTION

Many existing structures all around the world, which do not fulfil the specified requirements as it was expected for. These failures are due factors like rebar corrosion, failure of bonding between beam-column, and to aspects sudden loading like impact, earthquake, etc.

In such circumstances there are two possible solutions: replacement of Structure or retrofitting. Full structural replacement might have disadvantages such as high costs for material and labour, a stronger environmental impact and when possible, it is often better to repair or upgrade the structure by retrofitting.

The repair and strengthening of reinforced concrete beams, slabs, columns and beam-column joints in structural engineering applications has increased over past 20 years.

2. MATERIAL PROPERTIES AND MIX PROPORTIONS

2.1 Materials

Cement

Ordinary Portland Cement of 53 Grade manufactured by siddhi cement company was used in concrete mixes corresponding to IS-8112. The specific gravity of cement is 3.15.

Sand

Natural river sand is used as fine aggregate. As per IS: 2386 (Part III)-1963, the bulk specific gravity in oven dry condition and water absorption of the sand are 2.65 and 1.70% respectively.

Aggregate

Crushed stones of maximum size 20 mm are used as coarse aggregate. As per IS: 2386 (Part III)-1963 [6], the bulk specific gravity in oven dry condition and water absorption of the coarse aggregate are 2.85 and 0.80% respectively.

Water

Portable water was used to prepare the concrete mix and for the curing.

Basalt fiber

Basalt fiber is a material made from extremely fine fibres of basalt rock, Basalt fiber are basically fiber form of basaltic rocks.

So basalt fibres sustain almost all properties that basalt rocks possess. Basalt rocks are volcanic dense rocks. It is not an organic product, so it will not degrade with time.

The basalt fiber is somewhat more economical because no any other additives present in it. It has good tensile strength, and also has good resistance to chemical attack, impact load and fire with less poisonous hazes.

Table -1: Property of Basalt Fiber

Property	Results
Colour	Grey
Fiber diameter (µm)	13-20
Thickness (mm)	0.14
Bulk Density, (g/cm ³)	2.8
Ultimate tensile strength, (MPa)	3050
Cost of fiber per meter	750
Woven Pattern	Uni-directional

Epoxy Resin

An epoxy resin is binding agents with high tensile strength the higher viscosity epoxy resin can be used for surface coating or filling larger cracks or holes. Epoxy resin and hardener is used for bonding of the basalt fibre sheet. The strengthening was done by wrapping above fiber mat.

2.2 Mix Design

A standard mix M20 and M25 grade was calculated as per Indian Standard (IS 10262-2009). For each binder content, the W/C ratio were 0.50 and 0.45 respectively were determined by trial mixtures. The mix design is given in table-2

Table -2: Proportions of Mix Design

Material	M-20	M-25
Cement	310 kg/m ³	355 kg/ m ³
Water	155 kg/m ³	160 Liter
Fine aggregate	870 kg/m ³	732 kg/ m ³
Coarse aggregate	1187 kg/ m ³	1194.34 kg/ m ³

3 EXPERIMENTAL WORK

3.1 Reinforcement Detail

Longitudinal Steel: - 4 no-10mm Dia
 Shear reinforcement: - 8mm Dai @ 100 mmc/c

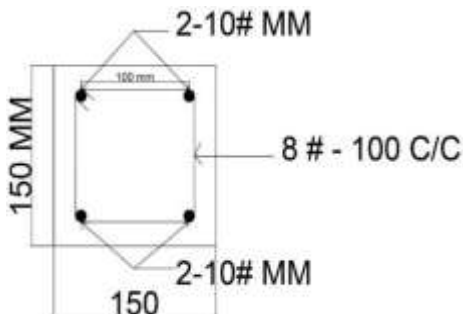

Fig-1: Reinforcement Detail

3.2 Corrosion of Reinforcement

The inducing of corrosion to the reinforcements was done by the Hydrochloric acid which was concentrated to 30%.

The reinforcements were place in the barrel filled with hydrochloric acid and were measured time to time for inducing exactly the corrosion that was required diameter wise.

Diameter of Reinforcement is measure using a Vermeer calipers.

Table -3: Corrosion Details

% Corrosion	Dia of Reinforcement before corrosion	Dia of Reinforcement After corrosion	Time taken for corrosion.	Weight loss after corrosion (%)
5	10mm	9.5mm	5 hours 5 min	4.98
10	10mm	9mm	10 hours 13 min	9.85
15	10mm	8.5 mm	15 hours 18 min	14.92

3.3 Casting of Beams

Three Aluminum moulds are used for casting the beam. The inside surface of the mould is oiled to facilitate easy removing of the beam from the moulds. Beams were reinforced with 2 bars of 10mm diameter in tension zone and 2 hanger bars of 10mm diameter in compression zone as to support illustrated in figure. To facilitate binding of the longitudinal steel and to maintain the clear cover, 8mm vertical stirrups at equal spacing were used.



Fig-2: Corroded Reinforcement



Fig-3: Casting Of Beam

3.3 Test setup of beam

All the beams were tested under 2 point loading in a Universal Testing Machine of 2000 kN capacity and the experimental setup is shown in Fig. 4.



Fig-4: Testing of Beam.

Above figure shows the test setup of beam. It consist of hydraulic jack through which load is applied on beam, load cell, the concentrated load is applied on beam, steel rollers are used to support the beam over it,

Table -4: Initial Crack and Ultimate load

Sr No	Beam Notification	Loads at Initial Crack (kN)	Ultimate load (kN)
1	CB -20	48.34	63.4
2	5CB -20	44.96	59.20
3	10CB - 20	41.38	56.22
4	15CB - 20	38.67	53.48
5	CB -25	64.10	86.97
6	5CB -25	59.38	80.70
7	10CB - 25	57.48	76.48
8	15CB - 25	52.87	72.82

3.4 Retrofitting Of Beams

Hand layup method is used for retrofitting of beams. The surface of the beam after curing is made rough with steel Wire brush and then cleaned with water to remove all dirt's for the proper bonding with fibre sheets. A layer of epoxy and Harder (2:1) is applied at an appropriate thickness of about 1 mm with brush. The basalt fiber sheets were measured and cut to the desired shape and dimensions. The Fiber were placed on the concrete surface and gently pressed onto the coated epoxy resin.



Fig-5: Surface Preparation and Applying Basalt fiber on Beam.

4. RESULTS

Table -5: Strength Increases of Retrofitted beam for M-20

Sr No	Wrapping pattern	Avg. Strength in Corrosion Percentage (N/mm ²)		
		5%	10%	15%
1	Full -U	98.65	93.21	89.18
2	Strip	89.07	83.96	79.83
3	Bottom	83.90	79.21	74.44

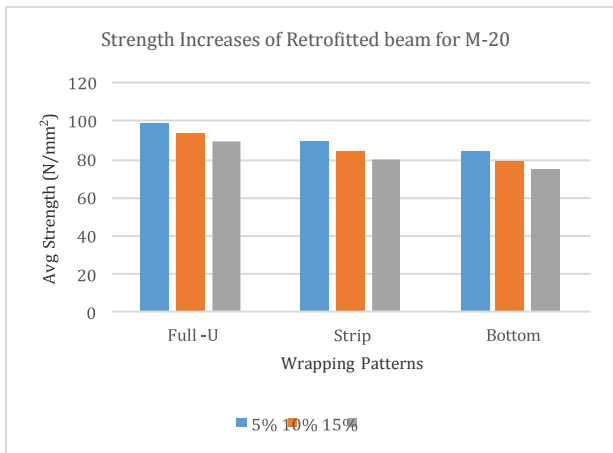

Chart -1: Strength Increases of Retrofitted beam for M-20

Table -6: Strength Increases of Retrofitted beam for M-25

Sr No	Wrapping pattern	Avg. Strength in Corrosion Percentage (N/mm ²)		
		5%	10%	15%
1	Full -U	134.29	127.21	121.22
2	Strip	121.48	114.15	109.88
3	Bottom	113.70	107.99	102.31

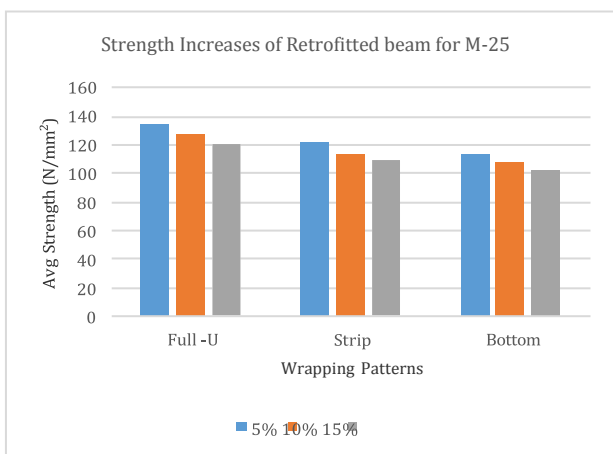

Chart -2: Strength Increases of Retrofitted beam for M-25

Table -7: Flexural Strength of Retrofitted beam for M-20

Sr No	Wrapping pattern	Avg. Flexural Strength in Corrosion Percentage (N/mm ²)		
		5%	10%	15%
1	Full -U	20.46	19.33	18.50
2	Strip	18.47	17.41	16.56
3	Bottom	17.40	16.43	15.44

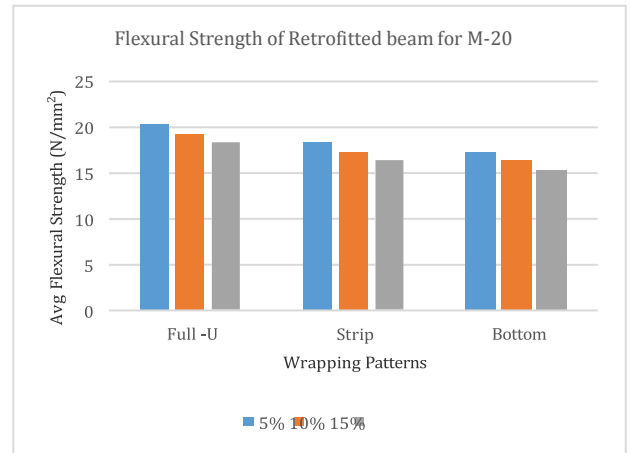

Chart -3: Flexural Strength of Retrofitted beam for M-20

Table -8: Flexural Strength of Retrofitted beam for M-25

Sr No	Wrapping pattern	Avg. Flexural Strength in Corrosion Percentage (N/mm ²)		
		5%	10%	15%
1	Full -U	27.85	26.38	25.14
2	Strip	25.30	23.68	22.79
3	Bottom	23.58	22.40	21.22

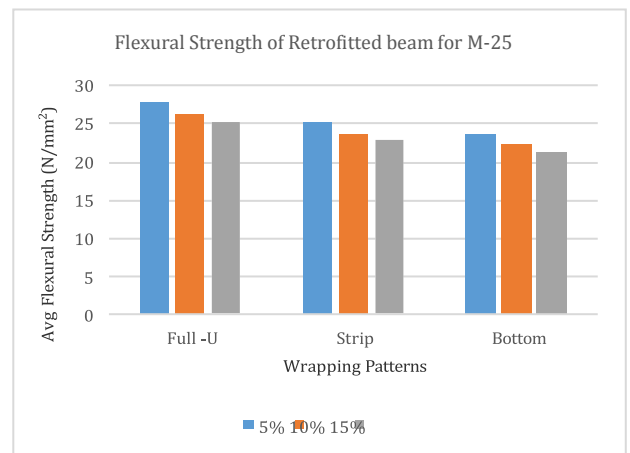

Chart -4: Flexural Strength of Retrofitted beam for M-25

5. SUMMARY OF RESULTS AND DISCUSSION

As the corrosion rate increases 5%, 10%, and 15% the weight of Re-bar decreases 4.98%, 9.85%, and 14.92% respectively as compared to control Specimen (Non Corroded).

As the corrosion rate increases 5%, 10%, and 15% Diameter of Re-bar decreases 9.5mm 9mm, and 8.5 mm respectively as compared to control Specimen (Non Corroded)

With increases corrosion rate 5%, 10%, and 15% the first Crack load was decreases 6.99%, 10.26%, 17.94% for M-20 and 7.36%, 10.94%, 17.52% for M-25 Grade of concrete as compared to control Specimen (Non Corroded)

With increases corrosion rate 5%, 10%, and 15% the Ultimate load was decreases 7%, 11.32%, 15.64% for M-20 and 7.21%, 12.06%, 16.27% for M-25 Grade of concrete as compared to control Specimen (Non Corroded)

After Retrofitting of beam the results shows that for 5% corrosion flexural Strength and ultimate load for U-Wapping, Strip Wrapping and Bottom Wrapping pattern increasing 66.63%, 50.46%, and 41.72% Respectively for M-20 Grade of concrete and 66.42%, 50.54% and 40.90% Respectively for M-25 Grade of concrete as compared to control Specimen (Non Corroded).

After Retrofitting of beam the results shows that for 10% corrosion flexural Strength and ultimate load for U-Wapping, Strip Wrapping and Bottom Wrapping pattern increasing 65.82%, 49.34%, and 40.88% Respectively for M-20 Grade of concrete and 66.33%, 49.27% and 41.20% Respectively for M-25 Grade of concrete as compared to control Specimen (Non Corroded).

After Retrofitting of beam the results shows that for 15% corrosion flexural Strength and ultimate load for U-Wapping, Strip Wrapping and Bottom Wrapping pattern increasing 66.75%, 49.26%, and 39.19% Respectively for M-20 Grade of concrete and 66.46%, 50.89% and 40.50% Respectively for M-25 Grade of concrete as compared to control Specimen (Non Corroded).

Basalt fiber retrofitting with U-wrapping Pattern improved the ultimate load carrying capacity and flexural Strength of corroded beams significantly high than other wrapping pattern.

6. CONCLUSIONS

As the corrosion rate increases, the ultimate stress and yield stress of Re-bar were found to decrease significantly.

The results indicate that cracking load carrying capacity of beam specimen reduced with increases of corrosion rate of reinforcement as compared to normal specimen.

The results indicate that ultimate load carrying capacity of beam specimen reduced with increases of corrosion rate of reinforcement as compared to normal specimen.

With the help of external wrapping of basalt fiber on beam flexural load carrying capacity of retrofitted beams are increases.

Basalt fiber retrofitting with U-wrapping Pattern improved the ultimate load carrying capacity and flexural Strength of corroded beams significantly high than other wrapping pattern. For both M-20 and M-25 for 5%, 10%, and 15% corroded beams.

ACKNOWLEDGEMENT

I feel heartening as a matter of respect and satisfaction to express my deep sense of gratitude to my highly-esteemed guide, Mr. A. R. JAMANI for their inspiring guidance, encouragement and constructive suggestions throughout the period of study and preparation of this work.

I am highly indebted to God & My Parents, who allow me to fly in open sky and encouraged me to make my career for higher studies. I am very much thankful to Jay Doshi, Darshil Shah, Tapan Gandhi, & Parth Rasalia for giving me a positive energy & support in my work all time at all different stages.

REFERENCES

- [1] Mr.Ankit .U. Oza, MR.Piyush Jain "Experimental study on Retrofitting of RC beam using Basalt Fibers" International Journal of Advance Engineering and Research Development - 2017.
- [2] Gang Wu; Yi-Hua Zeng "Experimental Study on the Flexural Behavior of RC Beams Strengthened with Steel-Wire Continuous Basalt Fiber Composite Plates" American Society of Civil Engineers- 2013.
- [3] R.Anandakumar, Dr.C.Selvamony, Dr.S.U.Kannan "Retrofitting of Concrete Specimens and Reinforced Concrete Piles Using Basalt Fibers" International Journal of Engineering Science Invention- 2013

- [4] A. Chandran and K.L. Muthuramu "Experimental Study of Flexural Behavior of RC Beams Strengthening with BFRP Sheets" Research Journal of Applied Sciences, Engineering and Technology 2015.
- [5] Balamuralikrishnan R., and Jeyasehar C. A. (2009), "Flexural behaviour of RC beams strengthened with Carbon Fiber Reinforced Polymer (CFRP) fabrics", The Open Civil Engineering Journal, 3, 102-109.
- [6] Ceroni F. (2010), "Experimental performances of RC beams strengthened with FRP materials", Construction and Building materials, 24, 1547-1559.
- [7] IS 456-2000 – "Code of Practice is an Indian Standard code of practice for general structural use of plain and reinforced concrete", Bureau of Indian Standards.
- [8] IS 10262:2009, "Guidelines for concrete mix design proportioning", Bureau of Indian Standards .
- [9] IS: 383-1970, "Specification for Coarse and Fine Aggregates from natural sources for Concrete", Bureau of Indian Standards.

BIOGRAPHIES



Prakash S. Bharvad
P.G Student, Department of Structural engineering, L.J Institute of engineering and technology, Ahmedabad, Gujarat, India



Abbas Jamani
Asst. Professor, Department of Structural engineering, L.J Institute of engineering and technology, Ahmedabad, Gujarat, India