

Numerical Investigation on Gas Turbine Rotor Blade

Azeemsha S S¹, Vinod Yeldho Baby²

¹Department of Mechanical Engineering, MACE, Kothamangalam, Kerala, India

²Professor, Department of Mechanical Engineering, MACE, Kothamangalam, Kerala, India

Abstract - Cooling of gas turbine blades is a major consideration because they are subjected to high temperature working conditions. Several methods have been suggested for the cooling of blades and one such technique is to have radial holes to pass high velocity cooling air along the blade span.

The forced convection heat transfer from the blade to the cooling air will reduce the temperature of the blade to allowable limits. Modeling of gas turbine blade is done in solid works 2016 design software. Finite element analysis is used in the present work to examine steady state thermal performance for SiC, N155 and Haste alloy X. Four different models consisting of solid blade and blades with varying number of holes (7, 8, 9 holes) were analyzed in this project to find out the optimum number of cooling hole. It is observed that as the no. of holes increases the temperature distribution increase. The steady state thermal analysis is carried out in ansys workbench software. It is observed that blade with 9 holes has showing more heat flux than the remaining blades. Finally the blade with 9 holes has giving optimum performance for prescribed loading conditions with average temperature of 1200 °C and convection 30°C.

1. INTRODUCTION

A turbine blade is the individual component which makes up the turbine section of a gas turbine. The blades are responsible for extracting energy from the high temperature, high pressure gas produced by the combustor. The turbine blades are often the limiting component of gas turbines. To survive in this difficult environment, turbine blades often use exotic materials like super alloys and many different methods of cooling, such as internal air channels, boundary layer cooling, and thermal barrier coatings. Blade fatigue is a major source of failure in steam turbines and gas turbines. Fatigue is caused by the stress induced by vibration and resonance within the operating range of machinery. To protect blades from these high dynamic stresses, friction dampers are used.

In a gas turbine engine, a single turbine section is made up of a disk or hub that holds many turbine blades. That turbine section is connected to a compressor section via a shaft (or "spool"), and that compressor section can either be axial or centrifugal. Air is compressed, raising the pressure and temperature, through the compressor stages of the engine. The temperature is then greatly increased

by combustion of fuel inside the combustor, which sits between the compressor stages and the turbine stages. The high-temperature and high-pressure exhaust gases then pass through the turbine stages. The turbine stages extract energy from this flow, lowering the pressure and temperature of the air and transfer the kinetic energy to the compressor stages along the spool. This process is very similar to how an axial compressor works, only in reverse.

The gas turbine obtains its power by utilizing the energy of burnt gases and the air which is at high temperature and pressure by expanding through the several rings of fixed and moving blades. The turbine drives the compressor so it is coupled to the turbine shaft. After compression, the working fluid were to be expanded in a turbine, then assuming that there were no losses in either component, the power developed by the turbine can be increased by increasing the volume of working fluid at constant pressure or alternatively increasing the pressure at constant volume. Either of there may be done by adding heat so that the temperature of the working fluid is increased after compression. To get a higher temperature of the working fluid, a combustion chamber is required where combustion of air and fuel takes place giving temperature rise to the working fluid. The turbine escapes energy from the exhaust gas.

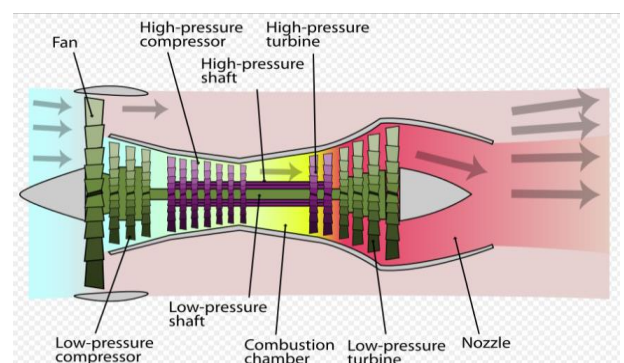

Fig -1: Schematic diagram of a twin spool jet engine.

2. LITERATURE REVIEW

V. Veeraragavan had mainly done the research on the aircraft turbine blades; his main focus was on 10 C4/ 60 C50 turbine blades models. He had used the conventional alloys such as titanium, zirconium, molybdenum, and

super alloys were chosen for the analysis. He had analyzed the effect of the temperature on the different material for the certain interval of times. And conclude the molybdenum alloys had better temperature resistance capability.

R D V Prasad, G Narasa Raju, M S S Srinivasa Rao, N Vasudeva Rao had done research on different types of the cooling technique which maintain temperature of the blade to allowable limits, Finite element analysis is used to examine steady state thermal & structural performance for N155 & Inconel 718 nickel-chromium alloys. Four different models consisting of solid blade and blades with varying number of holes (5, 9 & 13 holes) were analyzed to find out the optimum number of cooling holes. They had used two material Inconel 718 and Inconel 155 for their research work and found out Inconel 718 has the better thermal properties as the blade temperature and the stress induce is lesser.

S.Gowreesh et.al studied on the first stage rotor blade of a two stage gas turbine has been analyzed for structural, thermal, modal analysis using ANSYS 11.0 which is a powerful Finite Element Method software. The temperature distribution in the rotor blade has been evaluated using this software. The design features of the turbine segment of the gas turbine have been taken from the preliminary design of a power turbine for maximization of an existing turbo jet engine. It has been felt that a detail study can be carried out on the temperature effects to have a clear understanding of the combined mechanical and thermal stresses.

Kauthalkar et.al the purpose of turbine technology is to extract, maximum quantity of energy from the working fluid to convert it into useful work with maximum efficiency. That means, the Gas turbine having maximum reliability, minimum cost, minimum supervision and minimum starting time. The gas turbine obtains its power by utilizing the energy of burnt gases and the air. This is at high temperature and pressure by expanding through the several rings of fixed and moving blades. A high pressure of order 4 to 10 bar of working fluid which is essential for expansion, a compressor is required. The quantity of working fluid and speed required are more so generally a centrifugal or axial compressor is required. The turbine drives the compressor so it is coupled to the turbine shaft.

John.v et.al studied on the design and analysis of Gas turbine blade, CATIA is used for design of solid model and ANSYS software for analysis for F.E. model generated, by applying boundary condition, this paper also includes specific post-processing and life assessment of blade .How the program makes effective use of the ANSYS pre-processor to mesh complex turbine blade geometries and apply boundary conditions. Here under we presented how

Designing of a turbine blade is done in CATIA with the help of co-ordinate generated on CMM. And to demonstrate the pre-processing capabilities, static and dynamic stress analysis results, generation of Campbell and Interference diagrams and life assessment. The principal aim of this paper is to get the natural frequencies and mode shape of the turbine blade.

V.Raga Deepu et.al Studied on a Gas turbine is a device designed to convert the heat energy of fuel in to useful work such as mechanical shaft power. Turbine Blades are most important components in a gas turbine power plant. A blade can be defined as the medium of transfer of energy from the gases to the turbine rotor. The turbine blades are mainly affected due to static loads. Also the temperature has significant effect on the blades. Therefore the coupled (static and thermal) analysis of turbine blades is carried out using finite element analysis software ANSYS. In this paper the first stage rotor blade of the gas turbine is created in CATIA V5 R15 Software. This model has been analyzed using ANSYS11.0. The gas forces namely tangential, axial were determined by constructing velocity triangles at inlet and exist of rotor blades. After containing the heat transfer coefficients and gas forces, the rotor blade was then analyzed using ANSYS 11.0 for the couple field (static and thermal) stresses.

3. COMPUTER AIDED ANALYSIS OF GAS TURBINE ROTOR BLADE

The software uses the Finite Element Method (FEM). FEM is a numerical technique for analyzing engineering designs. FEM is accepted as the standard analysis method due to its generality and suitability for computer implementation. FEM divides the model into many small pieces of simple shapes called elements effectively replacing a complex problem by many simple problems that need to be solved simultaneously.

Static Analysis:

When loads are applied to a body, the body deforms and the effect of loads is transmitted throughout the body. The external loads induce internal forces and reactions to render the body into a state of equilibrium. Linear Static analysis calculates displacements, strains, stresses, and reaction forces under the effect of applied loads.

Material	Density (kg/m ³)	Young's modulus (Pa)	Poisson's ratio	Thermal conductivity (W/mk)
Silicon carbide	3100	4.1E+11	0.14	20.7
N155	8249	143 E+9	0.34 4	20.0
Haste alloy X	8300	144E+9	0.348	25

Fig 2: Properties Of Materials.

Material:N155

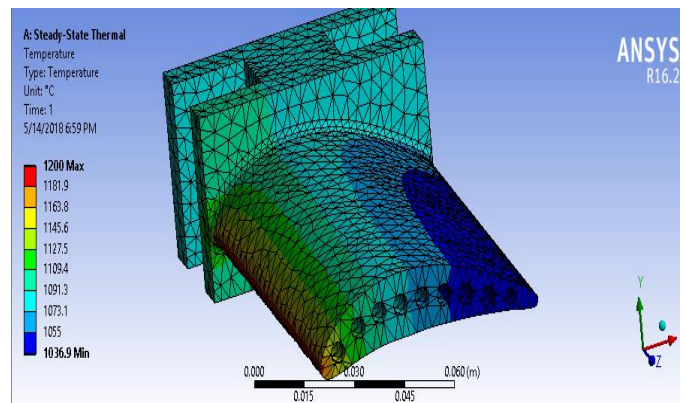
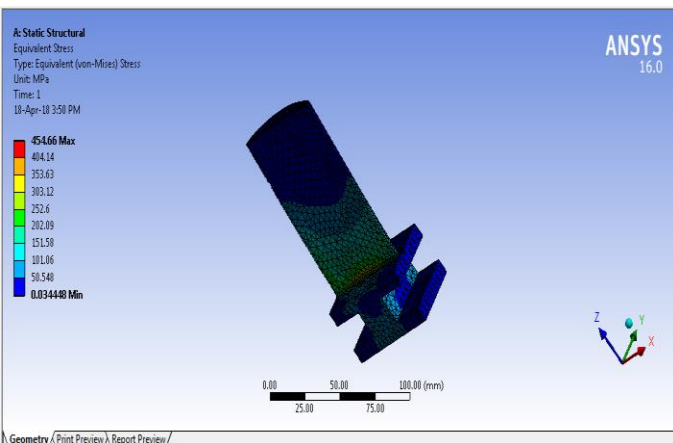
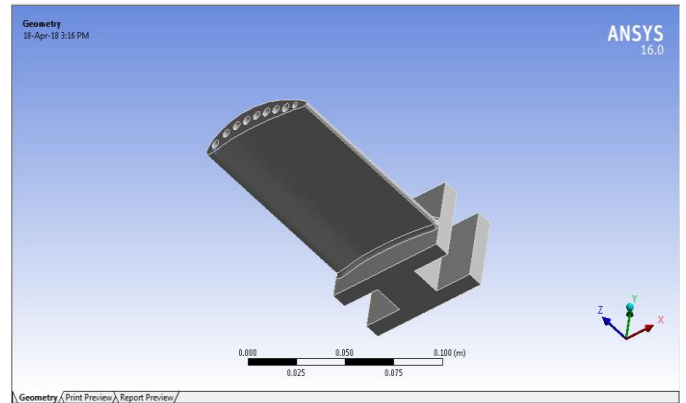
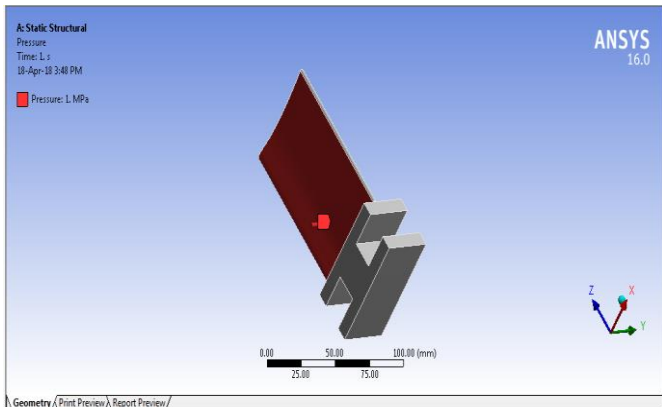

Thermal Stress Analysis:

Changes in temperature can induce substantial deformations, strains, and stresses. Thermal stress analysis refers to static analysis that includes the effect of temperature.

Material : N155

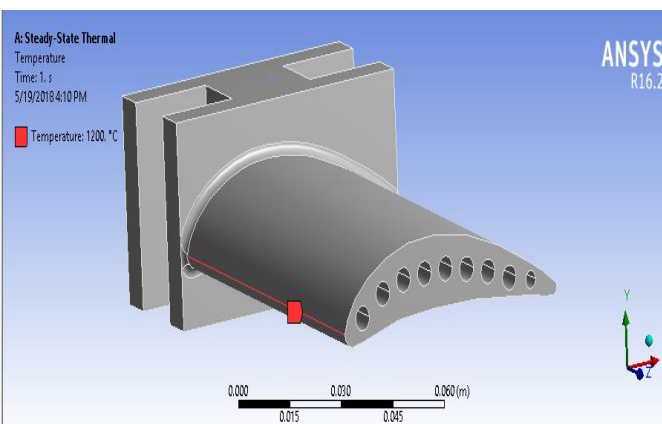

4. RESULTS AND DISCUSSION

4.1 STRUCTURAL ANALYSIS RESULTS

7 holes

Material	Stress (MPa)	Total deformation (mm)	Strain
Silicon carbide	455.09	1.1134	0.0033258
N 155	454.66	1.0241	0.0030349
Haste alloy X	454.69	1.0657	0.0031616

8 holes

Material	Stress (MPa)	Total deformation (mm)	Strain
Silicon carbide	476.23	0.39044	0.0011643
N 155	470.76	1.0835	0.0032957

Haste alloy X	470.95	1.0748	0.0032741
---------------	--------	--------	-----------

9 holes

Material	Stress (MPa)	Total deformation (mm)	Strain
Silicon carbide	476.98	0.39256	0.0011679
N 155	471.39	1.0901	0.0033042
Haste alloy X	471.53	1.0814	0.0032822

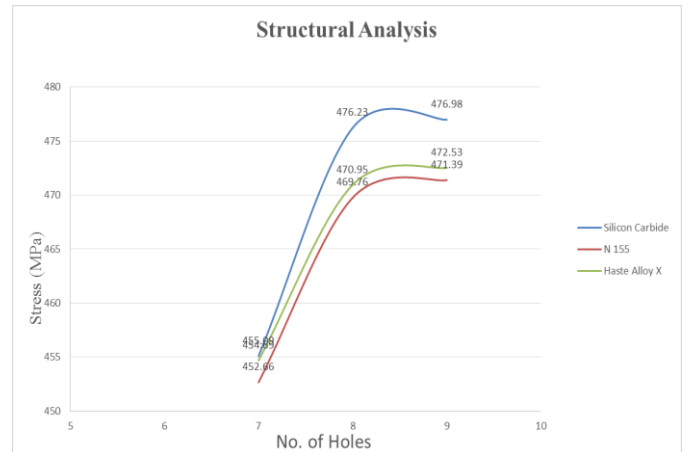

4.2: STEADY STATE THERMAL ANALYSIS RESULTS

7 holes

Material	Temperature distribution (°C)		Total Heat Flux (W/m ²)
	Max	Min	
Silicon Carbide	1200	1173.2	8.8599e5
N 155	1200	1053.4	8.129e5
Haste alloy X	1200	1080.2	8.2929e5

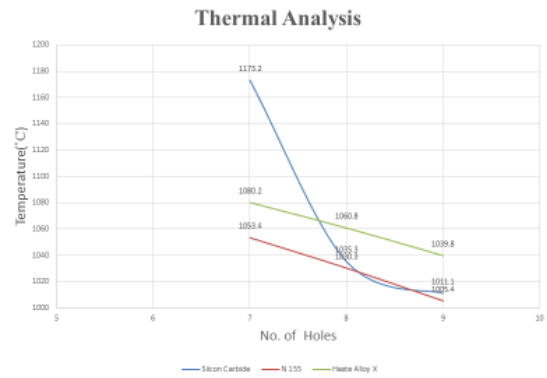

8 holes

Material	Temperature distribution (°C)		Total Heat Flux (W/m ²)
	Max	Min	
Silicon Carbide	1200	1035.3	1.02e6
N 155	1200	1030.3	1.016e6
Haste alloy X	1200	1060.8	1.0398e6

9 holes

Material	Temperature distribution (°C)		Total Heat Flux (W/m ²)
	Max	Min	
Silicon Carbide	1200	1041.1	2.4472e6
N 155	1200	1036.9	2.4385e6
Haste alloy X	1200	1066.4	2.4907e6

5. CONCLUSIONS

Modeling and analysis on gas turbine rotor blade is done. Modeling of turbine blade is done in solid works using various commands. Three models with 7holes, 8holes and 9holes are modeled. The gas turbine blade model is imported to ansys work bench software. Structural analysis is done at 1MPa pressure with three different materials such as Silicon carbide, N 155 and Haste alloy Structural deformations such as stress, deformation and strain are found and tabulated. From the results 7 holes gas turbine blade with N155 material obtaining low stress value compared to other. Next steady state thermal analysis is carried out on turbine blade by applying different materials such as, Silicon carbide, N 155 and Haste alloy X at temperature 1200°C and 30°C of convection. Temperature distribution and heat flux values are noted and are tabulated. From the analysis results we noticed that at 9 holes the N155 material is showing minimum temperature distribution. Thus from the study we can conclude that N155 material with 9 holes is more preferable compared to remaining.

REFERENCES

1. Jump up^ Bhagi LK, Rastogi V, Gupta P (2017). "Study of corrosive fatigue and life enhancement of low pressure steam turbine blade using friction dampers". *Journal of Mechanical Science and Technology*. 31: 17-27. doi:10.1007/s12206-016-1203-5.
2. Flack, p. 406
3. Jump up^ Flack, p. 407
4. ^ Jump up to:^{a b} Bhagi LK, Rastogi V, Gupta P (2013). Fractographic investigations of the failure of L-1 low pressure steam turbine blade. *Case Studies in Engineering Failure Analysis*, 1(2), pp.72-78
5. Gowreesh, S., Sreenivasalu Reddy, N. and Yogananda Murthy, NV. 2009. Convective Heat Transfer Analysis of a Aero Gas Turbine Blade Using Ansys, *International Journal of Mechanics And Solids*. 4: 39-46.
7. Facchini, B. and Stecco. S.S. 1999. Cooled expansion in gas turbines: a comparison of analysis methods, *Energy Conversion and Management*. 40: 1207-1224.
8. Mohammad, H., Albeirutty. Abdullah, S., Alghamdi., Yousef, S. Najjar. 2004. Heat transfer analysis for a multistage gas turbine using different blade-cooling schemes, *Applied Thermal Engineering*. 24: 563-577.
9. Mahfoud, K. and George, B. 1997. Computational study of turbine blade cooling by slot-injection of a gas, *Applied Thermal Engineering*. 17: 1141-1149.
10. Moyroud, F., Fransson, T. and Jacquet-Richardet, G. 2002. A comparison of two finite element reduction techniques for mistuned bladed-disks, *Journal of Engineering for Gas Turbines and Power*. 124: 942-953.
11. Giovanni, C., Ambra, G., Lorenzo, B. and Roberto, F. 2007 Advances in effusive cooling techniques of gas turbines, *Applied Thermal Engineering*. 27: 692-698.
12. Cun-liang, L., Hui-ren, Z., Jiang-tao, B. and Du-chun, X. 2010. Film cooling performance of converging slot-hole rows on a gas turbine blade, *International Journal of Heat and Mass Transfer*. 53: 5232-5241.
13. Zhang, JJ. Esat, II. And Shi, YH. 1999. Load Analysis with Varying Mesh Stiffness, *Computers and Structures*. 70: 273-280.
14. Hildebrand, FB. 1997. Introduction to Numerical Analysis, McGraw-Hill, New York.
15. Moussavi Torshizi, SE. Yadavar Nikraves, SM. and Jahangiri, A. 2009. Failure analysis of gas turbine generator cooling fan blades, *Engineering Failure Analysis*. 16: 1686-1695.
16. Cleeton, JPE. Kavanagh, RM. and Parks, GT. 2009. Blade cooling optimisation in humid-air and steam-injected gas turbines, *Applied Thermal Engineering*. 29: 3274-3283.
17. Krishnamoorthy, C. 1994. Finite Element Analysis Theory and Programming, Tata McGraw-Hill, New Delhi.
18. Martin, HC. And Carey, GF. 2006. Introduction to the Finite Element Analysis, McGraw Hill Publishing Co Ltd, New Delhi.
19. Facchini, B. and Stecco. S.S. 1999. Cooled expansion in gas turbines: a comparison of analysis methods, *Energy Conversion and Management*. 40:1207-1224.