

# Advance Robotics Technology on Crash Analysis of Automobile Bumper by Varying Suitable Input Parameter in Order to Control Energy Absorption for Improve Passenger Car Safety Aspect

Sagar P Dhamone<sup>1</sup>, Dr Arun kumar P<sup>2</sup>

<sup>1</sup>Department of Mechanical Engineering, KLS's G.I.T, India

<sup>2</sup>Associate Professor in Mechanical Engineering, KLS's G.I.T, India

\*\*\*

**Abstract:** The goal of this work is to mitigate the degree of damage to passengers caused by automobile collisions. Crash phenomena involving road vehicles were investigated for the purpose of developing an impact attenuation design that can withstand speeds higher than the current specified range of up to 4 km/h (for a bumper). Different impact attenuation systems in the vehicle were studied with emphasis on the bumper modeling, material consideration, automatic machine handling, Robotics sensor for Bumper can achieve the desirable properties such as low weight, high fatigue strength, accessories in automation, improvement in quality of products.

Manufacturing by using advanced tools to achieve better quality output such as (RP), Injection moulding or fabrication of glass fiber based hybrid composites material.

Automotive development cycles are getting shorter by the day. With increasing competition in the marketplace, the OEM's and suppliers main challenge is to come up with time-efficient design solutions. Researchers are trying to improve many of existing designs using novel approaches. Many times there is conflicting performance and cost requirements, this puts additional challenge with R&D units to come up with a number of alternative design solutions in less time and cost compared to existing designs. These best solutions are best achieved in a CAE Environment using some of the modern CAD and FEM tools such tools are capable of effecting quick changes in the design within virtual environment.

A mathematical model for a bumper was developed Simulation of impact of the bumper against a fixed barrier was performed. A varying suitable parameter into the bumper system to improve on the attenuation of the impact and kinetic energy absorption capacity an innovated experiment testing method is developed for achieving accurate results such as Bumper impact test arrangement Full Frontal Impact Test, Offset Frontal Crash Testing, in order to control energy Absorption for improve passenger car safety aspect

The combination of all above investigation gives better results output, high strength, cost and weight reduction passenger safety, easily method to fabricated and manufacturing, experiment setup for crash analysis, better tools for design and analysis, high strength with less weight material fended out that achieve 3 times speed higher than the speed for which current conventional bumpers are designed to attenuate (i.e. 4 km/h).

**Keywords--** Investigation; Bumper; Design; Material condition; Analysis; Testing

## 1 INTRODUCTION

The rapid development of auto industry, traffic accident rate is higher and higher; all countries begin to attach importance to the vehicle safety. Research on the safety of bumper collision has large help to improve the vehicle collision safety, so the bumper safety performance has important significance, material consideration shield made of steel, aluminum, rubber, plastic or composite materials can achieve the desirable properties such as low weight, high fatigue strength, easy forming and high strength, they are suitable for material replacing the use of plastic in auto bumpers and fascia's gives designers a tremendous amount of freedom when it comes to styling a prototype vehicle, or improving an existing model. Plastic can be styled for both aesthetic and functional reasons in many ways without greatly affecting the cost of production. Plastic bumpers contain reinforcements that allow them to be as impact-resistant as metals while being less expensive to replace than their metal equivalents Plastic car bumpers generally expand at the same rate as metal bumpers under normal driving temperatures and do not usually require special fixtures to keep them in place In a case of a collision to the front or rear occurring at low speed, the bumper shall absorb the energy to prevent or reduce damage to the car. Consequently, the purpose of the bumper is not to be a structural component that actively contributes to occupant protection during front or rear collisions but more to protect components like the hood, lights and cooling.

Different countries have different performance standards for bumpers, Automation, Under the

International safety regulations originally developed as European standards and now adopted by most countries outside North America, a car's safety systems must still function normally after a straight-on pendulum or moving-barrier impact of 4 km/h (2.5 mph) to the front and the rear, and to the front and rear corners of 2.5 km/h (1.6 mph) at 45.5 cm (18 in) above the ground with the vehicle loaded or unloaded. In North America (FMSS: Federal Motor Vehicle Safety Standards) and Canada (CMVSS: Canadian Motor Vehicle Safety Standards), it should be meet 4KMPH pendulum and barrier impacts.

Automotive Industry Standards Committee (AISC) specified the standards for Automation and vehicle test In India AIS-006- Automotive vehicle-Bumper Fitment on M1 Vehicles – Test Methods AIS-007 (Revision 4) Amd No. 1- Information on Technical Specifications to be submitted by the Vehicle Manufacturer Crash Analysis the deformation, stress, and energy absorbing capacity of various structural components of a vehicle hitting a stationary or moving object The component is said to be crashworthy (safe) if it meets the plastic strain and energy targets Bumper is one of the components which is used to protect passengers from front and rear collision Bumper crash tests are necessary for instance to calculate the energy absorption of this component during a crash.

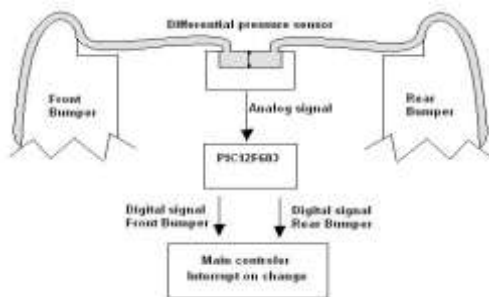

Fig.1: Model of bumper

Automotive development cycles are getting shorter by the day. With increasing competition in the marketplace, the OEM's and suppliers main challenge is to come up with time-efficient design solutions, Advance robotics & Automation

Researchers is trying to improve, advance robotics technology for manufacturing, sensing technology, design, reducing in energy absorption, conflicting performance and cost requirements, this puts additional challenge with R&D units to come up with a number of alternative design solutions in less time and cost compared to existing designs. These best solutions are best achieved in a CAE environment using some of the modern CAD and FEM tools. Such tools are capable of effecting quick changes in the design within virtual

environment & Robotics techniques gives acquires, Reduction in production costs, Reduction in accidents and hence safety for workers can achieve

## 2. LITERATURE

Previous Literatures mainly focuses on the most important parameters related to impact are studies by many researchers. It was observed that, major injury due to impact velocity of around 20-30 kmph was affected to the knee ligament.

**Davoodi et al.** Proposed conceptual design of fiber reinforced epoxy composite bumper absorber as a pedestrian energy absorber. The energy absorption capacity was sufficient for pedestrian impact and it could possible to use as substitute for the existing materials such as EPP foam for low impact collision.

**Javad ET. al.** (2009) --- has discussed, the most important parameters including material, thickness, and shape and impact condition were studied for design and analysis of an automotive front bumper beam to improve the crashworthiness design in low-velocity impact. The simulation of original bumper under condition impact was according to the low-speed standard of automotive stated in E.C.E. United Nations Agreement, Regulation no. 42, 1994. The bumper beam analysis was accomplished for composite and aluminum material to compare the weight and impact behavior. The strength in elastic mode was investigated with energy absorption and impact force in maximum deflection situation. A good design of this part of automotive must prepare for the safety of passengers; meanwhile, should have low weight. Beside the role of safety, fuel efficiency and emission gas regulations are being more important in recent years that encourage manufacturer to reduce the weight of passenger cars.

**Claes Magnusson --- R&D Coordinator, Volvo Cars Body Components, Olofström, Sweden**

A study of high strength stainless and carbon steels at Volvo Cars Body Components. It demonstrates the difference in formability and crash absorbing capability for a specific component. The austenitic stainless grades and the carbon steel Trip700 undergo a microstructure transformation during plastic deformation. This means that traditional forming limit curves index the formability to low for these types of materials. Instead, a forming limit dome height diagram should be used to index the formability for all type of materials. The crash impact absorbing capabilities was highest for the bumper that was made in high strength stainless steel since that material had the highest yield stress of all materials in this study

**2.1 Conclusion:** Previous research mainly focuses on the most important parameters such as

- Improvement of the structural adhesive increases the difficulties in crash simulations of adhesive-bonded vehicle structures.
- Manufacturing by injection molding parameters on a car bumper and analysis model car bumper using plastic flow simulation software
- To increase crash performance in automotive vehicles it is necessary to use new technique

## 2.2 Gap in literature

- There are few studies reporting about the work done related to improvement in the design, manufacturing, front bumper of passenger car.
- The applicability of these studies for passenger cars (India) is not validated.
- Present studies have not identified the effect of shape, size and or material.
- The safety of the passenger needs to be increased.
- The impact analysis of the passenger cars considering the material and size for the Indian cars.
- The use of sensing technology is under research stage
- Considering friction damper we improve energy absorption capacity of the bumper.
- Using mat lab for simulation of design parameters can build a physical model.

## 3 The aim of this paper is to study front bumper of one of the existing passenger car in Indian market.

India is the 10th largest producer of automobiles in the world. The country's attention to vehicle safety requirements has progressed significantly since the year 2000. This mission of road safety research is to reduce the incidence of road traffic Accidents and to minimize their effects once an accident has happened contrast, the goal of this dissertation is to reduce the effect of crash impact on passengers in collision of vehicles traveling at medium speeds (40 km/h to 56 km/h) automobile bumpers are designed to withstand impact energy equivalent to 4 km/h. This corresponds to rolling impact and it would be beneficial to improve upon this design criterion.

The specific objectives are to:

- To study existing passenger car front bumper in Indian market for possible design modifications as discussed earlier
- Improve automobile bumpers to enable them withstand impact energy of vehicles traveling at several times the speeds conventional bumpers are designed for.
- Model and simulate impact phenomenon in order to study crash dynamics.
- Use information from the simulation to generate design parameters for better impact attenuation bumpers.
- Propose designs of a bumper that could attenuate the impact energy of vehicles traveling at speeds several times the specified speeds for the design of a conventional bumper.
- Carry out impact analysis using CAE to study performance of modified bumper against existing front bumper
- Design, analysis, material condition & generating energy absorption equation by FEM approach
- Adopting advance technology such as robotics, automation, sensing to improve passenger re safety aspect
- A mathematical model for a bumper was developed. Simulation of impact of the bumper against a fixed barrier was performed.

## 4 Researchers are trying to improve many of existing designs, automation & sensing techniques

### 4.1 Design modifications can be suggested or tried out on following basis;

- **Performance related parameters of bumper**

The optimization of molding parameter effect is very important for the automotive industry because it gives beneficial effects in production costs due to less material being used and shorter cycle times.

- **Energy absorption capability -**

The cushion provides the maximum amount of energy absorption in the minimum amount of space. This maximized absorption results in minimized end loads as compared to urethane bumpers and rubber bumpers.

- **New and lightweight materials –**

The materials of the bumper manufacturing process should be very light in weight like plastic or elastic or rubber materials. It is just like foam like light weighted material like foam plastics.

- **Shape and Size –**

The size and the shape of the bumper should be comfortable for the frontal view of the car. It is also attractive as well as light weighted which protects the frontal side of the car.

- **Robotics Sensor for Bumper**

There are two different sensors, the Bumper Sensor and the Limit Switch, that act as touch sensors. Despite their differences in appearance and usage, both sensors operate in a similar matter, and can be programmed in the same way.



Fig.2: Sensor assembly of the car bumper



Figure no. 3: Side view of a bumper

To modeling the actual dimension of the car bumper into the SolidWork software and analyze Automobile Bumper, Beam, supporting part & vehicle model by using FE software (ALGOR).

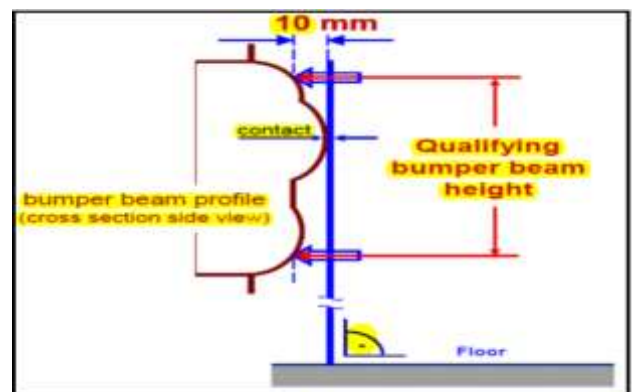

Figure.4: Measuring the Qualifying Bumper Beam Height.

## 4.2 Methodology

The study will focus on existing design performance, advantage and limitations. Based on Observations design improvements will be made in terms of shape & material based on design Modification objectives.

Modified front bumper design will be tested using FEM software for impact loads as per international standards.

### 4.2.1 Measuring the Qualifying Bumper Beam Height

After removing all detachable components (e.g. energy absorbing materials) the bumper beam height shall be measured from a vertical plane contacting the beam up to 10 mm into the profile to get the qualifying bumper beam height. The procedure is shown in Figure 4.

### 4.2.2 Key steps to a crash analysis study

A crash analysis study includes six key steps:

1. Identify the locations that are candidates for improvement.
2. Quantify the main crash trend(s) at a particular location.
3. Determine the source of the problem(s).
4. Evaluate types of improvements to address the crash problem(s).
5. Obtain an expert opinion about safety improvement(s).
6. Obtain funding to implement a safety improvement.

#### 4.2.3 The analyses study results

- To analyze the mechanical properties on front part (fascia) of car bumper
- To analyze on mechanical properties focus on stress analysis
- To modeling the actual dimension of the car bumper into the Solid Work software and analyze by using FE software (ALGOR).
- The element type is decided based on geometry size & shape, type of analysis, time allotted For project, for meshing the conventional model which was developed in CATIA software has to be meshed for analysis of crash. For this HYPERMESH software is used.

Mesh element size -10 mm

Element Type = Single order shell elements

Element formulations = ELFORM 16

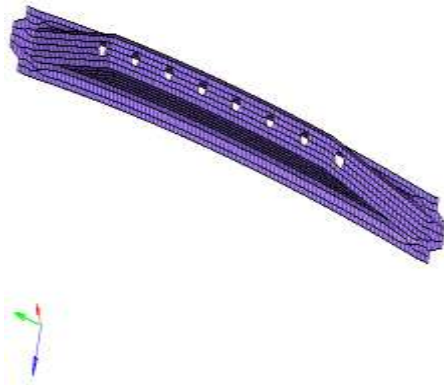

Figure 5: Mesh model of the bumper beam

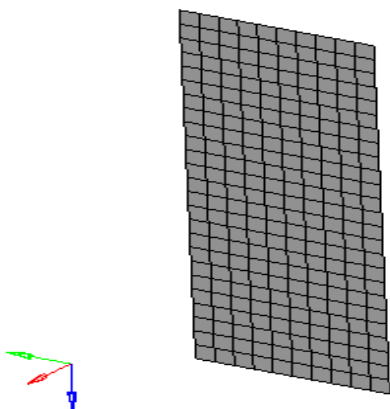

Figure 6: Rigid wall

- To investigate material consideration shield made of steel, aluminum 2014, rubber, ABS, PVC, composite materials or smart material can achieve the desirable properties such as low weight, high fatigue strength
- To investigate polymer composite material bumper (Proton Pesona) based on their geometry and other parameters that influence the compatibility of car bumper.
- To evaluate failure mechanism of the car bumper:
- To study the load distribution on the bumper either it is uniformly distributes to all the part during the analysis.
- To predict the critical point
- The goal of this work is to mitigate the degree of damage to passengers caused by automobile collisions.
- Different impact attenuation systems in the vehicle were studied with emphasis on the bumper modeling, analysis and design.
- A passive friction element was introduced into the bumper system to improve on the attenuation of the impact and kinetic energy absorption capacity
- The goal of this paper is to design a bumper with minimum weight by employing the Glass Material Thermoplastic (GMT) materials
- The experiments revealed that higher energy absorption could be achieved with the addition of a friction element to traditional bumpers.
- Performance related parameters of bumper

#### 4.3 Energy absorption capability

The main objective of the project is to determine energy absorption structure to absorb the impact energy during a low speed collision. Low speed collision is defined as within the range of 2.5 km/h to 4 km/h. In order to achieve the main objective, the analysis of stress distribution on the bumper due to the collision, would be set as the secondary objective.

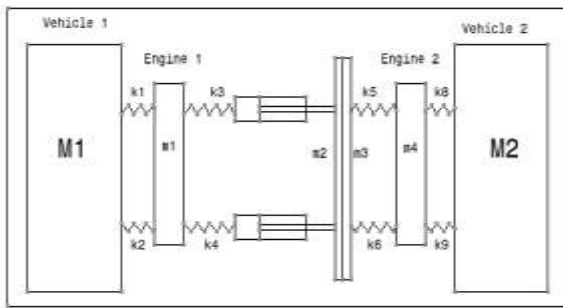

Figure.7: Schematic model of the crash system

The force experienced by the automobile is decreased.

Where,  $M$  - is mass

$V$  - Is initial velocity

$V_1$  - is the final velocity and

$KE_{nc}$  - is the non-conservative kinetic energy, or the sound and heat energy lost in the collision.

This phenomenon is expressed more formally through the application of Newton's second law of motion, as: -  
 $F = M \cdot a$

Where,  $a$  = can be represented by the change in velocity over the change in time.

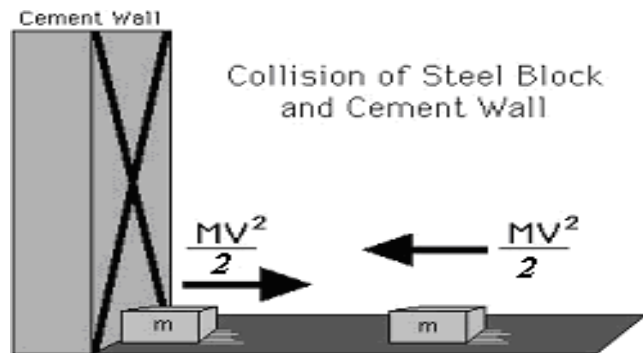

Figure.8: Collision of Steel Block & cement wall

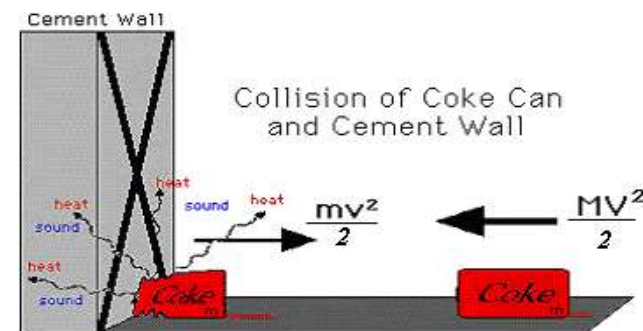

Figure.9: Collision of Coke can and cement wall

The governing energy equation Also, Substituting the previous equation for 'a' in Newton's second law yields:

From this equation, it is clear that as the time of the collision decreases, the force experienced by the automobile increases dramatically Mass -point, element concentrated mass at C.G. of the component, spring - translations & rotations stiffness, damper- damping coefficient

CASE NO.	1	2	3	4
Impact Condition				
Bumper Arrangement				
Velocity 'Ve'	$V$	$\frac{V}{2}$	$V_1 + V_2$	$\frac{V_1 + V_2}{2}$
Weight per bumper 'We'	$W$	$2W$	$\frac{W_1 W_2}{W_1 + W_2}$	$\frac{2W_1 W_2}{W_1 + W_2}$
$W$ = Maximum weight on rail EXCLUDING any SUSPENDED load. $V$ = Maximum velocity.		$W_e$ = Equivalent Weight for Bumper sizing. $V_e$ = Equivalent Velocity for Bumper sizing.		

Table 1 application for Bumpers of the same type used together

The study will focus on modifying few of above stated parameters to suggest improvements in existing bumper of passenger car/ SUV present in Indian markets. First, study will focus on studying existing design and based on observations, design improvements will be suggested. Modified front bumper design will be tested using FEM software for deflection, impact force and stress distribution. Results of modified bumper will be compared against existing design. FEM is backbone of today's automotive industry. In recent times FE analysis is widely used to validate the complex designs like bumper. Use of FEA not only reduces product development time but also saves lot of cost. Hence, this work proposes FE analysis of bumper to validate the design modifications in from bumper of car.

This study will use commercial FEA tools such as ANSYS, Abaqus, LSDYNA, etc for carrying out FE analysis limited to the Bumper as a single component (though, the boundary conditions would take into consideration its fitment with the mating parts in the assembly).

• **Finite Element Analysis**

Finite element method is used to analyze structures by computer simulations and therefore it helps to reduce the time required for prototyping and to avoid numerous

test series. The modeling and analysis will be done using Finite element Analysis software.

**• Steps for finite element analysis:**

- Preprocessing
- Creating the model
- Defining the element type
- Defining material properties
- Meshing
- Applying loads
- Applying boundary conditions
- Solution: Assembly of equations and obtaining solution
- Post processing: Review of results such as deformation plot, stress plot, etc

**5 Alternative methods for computation/ validation**

The component would be tested over a physical setup & results so obtained would be compared with the standard

**5.1 Types of Crash Testing**

- Environmental and Climatic Testing
- Structural and Rigidity Testing
- Endurance and Durability Testing
- Functional and Performance Testing

Above testing will provides parameters acting on bumper such as climate, rigidity, endurance, duration & performance

**5.2 Offset Frontal Crash Testing:**

Here only one side of a vehicle's front end, not the full width, hits the barrier so that a smaller area of the structure must manage the crash energy. This means the front end on the struck side crushes more than in a full-width test, and intrusion into the occupant compartment is more likely.



Figure 10: Frontal Offset Crash Test

**5.3 Full Frontal Impact Test:**

Crashing the full width of a vehicle into a rigid barrier maximizes energy absorption so that the integrity of the occupant compartment, or safety cage, can be maintained in all high-speed crashes. Full-width rigid-barrier tests produce high occupant compartment decelerations, so they're especially demanding of restraint systems.



Figure 11: Frontal Impact Crash Test.

- Bumper impact test arrangement

**5.4 Advance automation techniques used for bumper**

**5.4.1 Rapid prototyping technologies:** Prototyping or model making is one of the important steps to finalize a product design. It helps in conceptualization of a design. Before the start of full production a prototype is usually fabricated and tested. RP process belong to the generative (or additive) production processes unlike subtractive or forming processes such as lathing, milling, grinding or coining etc. in which form is shaped by material removal or plastic deformation. In all commercial RP processes, the part is fabricated by deposition of layers contoured in a (x-y) plane two dimensionally. The third dimension (z) results from single layers being stacked up on top of each other, but not as a continuous z-coordinate.

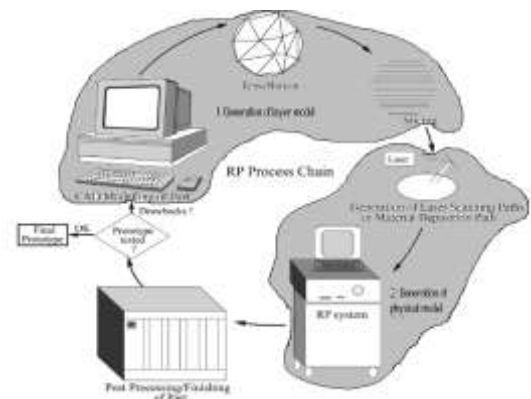

Figure 12: RP process chain showing fundamental process steps

The RP use for Automation of bumper can be possible by Stereolithography

### 5.4.2 Stereolithography

In this process photosensitive liquid resin which forms a solid polymer when exposed to ultraviolet light is used as a fundamental concept. Due to the absorption and scattering of beam, the reaction only takes place near the surface and voxels of solid polymeric resin are formed. A SL machine consists of a build platform (substrate), which is mounted in a vat of resin and a UV Helium-Cadmium or Argon ion laser. The laser scans the first layer and platform is then lowered equal to one slice thickness and left for short time (dip-delay) so that liquid polymer settles to a flat and even surface and inhibit bubble formation. The new slice is then scanned. Schematic diagram of a typical Stereolithography apparatus is shown in figure15

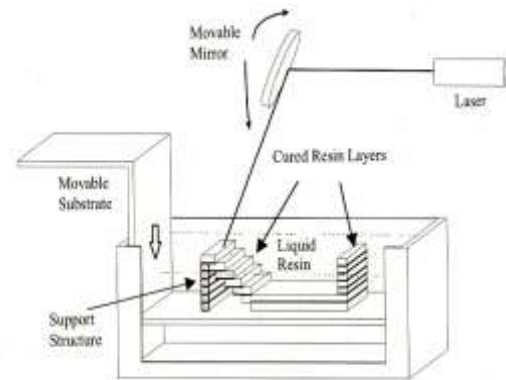

Figure 15: Stereolithography

Overhangs or cantilever walls need support structures as a green layer has relatively low stability and strength. These overhangs etc. are supported if they exceed a certain size or angle, i.e., build orientation. The main functions of these structures are to support projecting parts and also to pull other parts down which due to shrinkage tends to curl up (Gebhardt, 2003). These support structures are generated during data processing and due to these data grows heavily specially with STL files, as cuboid shaped support element need information about at least twelve triangles. A solid support is very difficult to remove later and may damage the model. Therefore a new support structure called fine point was developed by 3D Systems (figure 6) and is company s trademark. Build strategies have been developed to increase build speed and to decrease amount of resin by depositing the parts with a higher proportion of hollow volume. These strategies are devised as these models are used for making cavities for precision castings. Here walls are designed hollow connected by rod-type bridging elements and skin is introduced that close the model at the top and the bottom. These models require openings to drain out uncured resin.

- Selective Laser Sintering
- Fused Deposition Modeling
- Laminated Object Manufacturing

#### Following steps will be performed to execute

##### 1 Literature Review

Selection of appropriate Car/ SUV/ MUV or heavy duty vehicle

Understanding functional requirements of the front bumper/ rear bumper

2 To study existing bumper for various functional requirements and list out advantages and limitations of existing design

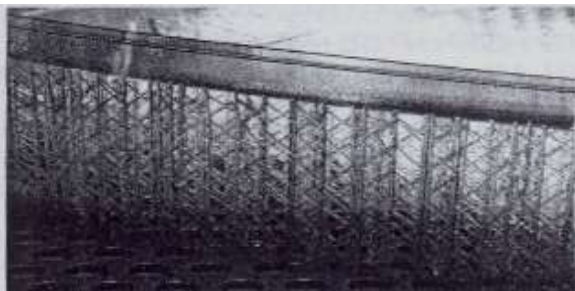

Figure 13: Fine point structure for Stereolithography.

In new SL systems, a blade spreads resin on the part as the blade traverses the vat. This ensures smoother surface and reduced recoating time. It also reduces trapped volumes which are sometimes formed due to excessive polymerization at the ends of the slices and an island of liquid resin having thickness more than slice thickness is formed (Pham and Demov, 2001). Once the complete part is deposited, it is removed from the vat and then excess resin is drained. It may take long time due to high viscosity of liquid resin. The green part is then post-cured in an UV oven after removing support structures.



Figure NO- 14 RP Product of Bumper



- 3 CAD modeling of modified front bumper & identification of material to achieve low weight & high strength
- 4 Developing mathematical equation related to bumper energy absorption and Simulink with math lab
- 5 Impact analysis using CAE software
- 6 Automation of Bumper by using advance technique
- 7 Comparing results of modified front bumper against existing bumper
- 8 Experiment Testing
- 9 Developing innovation method & experiment for analysis energy absorption of automobile bumper with crashworthiness

## 6 CRASHWORTHINESS OBJECTIVES:

Vehicle crashworthiness and people safety remain among the most important and challenging design considerations in the automotive industry. Early in the history of vehicle structural developments, vehicle bodies were manufactured from wood, and the goal of crashworthiness was to avoid vehicle deformations as much as possible. Designers create vehicles to provide occupant protection by maintaining integrity of the passenger compartment and by simultaneously controlling the crash deceleration pulse to fall below the upper limit of human tolerance. Therefore, the main objectives of crashworthiness is an optimized vehicle structure that can absorb the crash energy by controlled vehicle deformations while maintaining adequate space so that the residual crash energy can be managed by the restraint systems to minimize crash loads transfer to the vehicle residents. Moreover, vehicle crashes occur over a wide range of speeds, persisting for a fraction of a second, such as when a vehicle hits a tree, or for few seconds as in rollover events. These factors illustrate some of the complex tasks involved in the design of vehicle structures to satisfy crashworthiness constraints for all collision situations. Accident reform and analysis of motor vehicle crashes provide important information regarding the safety performance of vehicle in the traffic environment. These methods do not provide sufficient quantitative information necessary for vehicle design, such as deceleration pulse, resident kinematics or occupant loads. So, design engineers rely on a combination of standard laboratory tests, proving ground evaluations, and analysis to achieve safety objectives. At present vehicle crashworthiness is evaluated in four distinct modes like frontal, mode, rear mode and rollover crashes.

## 7 DISCUSSIONS

In order to reduce the impact injury to the resident, various moderation systems have been designed, exist and will be continuously improved for resident protection during a vehicular crash event. At present pursuit for continued improvement in automotive safety, various self-discipline systems have been developed to provide occupant protection in a wide variety of crash environments under different directions and conditions. It is extremely difficult to present scrupulous mathematical treatments to cover resident safety in complicated real world situations. In this paper, some fundamental principles of dynamics are presented and applied to examples with primary discussions on the vehicle response in frontal impact analysis only, even though side crash events are lightly touched upon. The vibration, collision and energy absorption analysis will be discussed on further result.

## Conclusion

From above study we concluded that Selection an appropriate Car/ SUV/ MUV or heavy duty vehicle can get desirable output on crashworthiness of bumper such as material identification modeling & analysis different component can achieve high strength, reduction in weight which can with stand impact absorbed by energy at the load acting on crashworthiness

The permissible strain values can be achieved by changing the thickness & material of bumper components. Changing the thickness & material is very cost effective way to get the assembly in safety zone as compared to others such as change in geometry or addition of ribs.

Crumple zones play an important role in securing the passenger compartment. Crumple zones are designed to sponge up the impact energy. Hence crumple zones play an important role in the safety of the occupant of the car by deforming exactly as calculated and absorbing most of the impact energy. As a result of crumple zones

The international standard is compared with results analysis achieve desirable parameter, innovation development method is identify for performing experiment analysis on energy absorption on crashworthiness of bumper

By using advance technique of automation, sensing & robotics we achieved 98 acquires, increase in productivity, uniform components are produced.

**REFERENCES**

- (1) Butler M, Wycech J, Parfitt J, and Tan E, "Using Terocore Brand Structural Foam to Improve Bumper Beam Design", SAE Technical Paper, 2002,
- (2) Carley ME, Sharma AK, Mallela V, "Advancements in expanded polypropylene foam energy management for bumper systems", SAE Technical Paper, 2004
- (3) Evans D and Morgan T, "Engineering Thermoplastic Energy for Bumpers", SAE Paper, 1999
- (4) Witteman WJ, "Improved Vehicle Crashworthiness Design by Control of the Energy Absorption for Different Collision Situations", Doctoral dissertation, Eindhoven University of Technology, 2000.
- (5) Jovan Obradovic, et. al. "Lightweight design and crash analysis of composite frontal impact energy absorbing structures." Science Direct paper 2011. Page no.423-430
- (6) Ping Zhu , et. al. "Metamodeling development for reliability-based design optimization of automotive body structure." Science Direct paper 2011. Page no.729-741
- (7) Xin Yang, et. al."Modeling of high strength steel joints bonded with toughened adhesive for vehicle crash simulations" Science Direct paper 2012. Page no.21-32
- (8) Belingardi, G., Avalle, M., Chiara, A., Crushing Behaviour of Aluminium Circular Tubes, 4th International Conference ATA-MAT, Torino, Italy, 1994. References 180
- (9) Landheer, D., Rapid Design of Crash Properties for Safe Automobiles: A Conceptual Approach, Ph.D. thesis, Eindhoven University of Technology, Laboratory for Automotive Engineering, Eindhoven, The Netherlands, 1997. References 183
- (10) JavadMarzbanrad, ( 2009),"Design and analysis of an automotive bumper beam in low-speed frontal crashes" Science Direct paper pp.902-911.
- (11) Tawfik Khalil and Paul Du Bois, "Finite Element Analytical Techniques and Applications to Structural Design"
- (12) Manufacturing System Design of Automotive Bumper Manufacturing
- (13) David S. Cochran, Joachim Linck, and Jey Won Massachusetts Institute of Technology, Cambridge,Massachusetts - Patrick Neise, Technical University of Munich, Germany
- (14) Rapid prototyping technologies, applications and part deposition planning by pulak m. pandey