

# CFD ANALYSIS ON THE PERFORMANCE OF CENTRIFUGAL PUMP IMPELLER BY CHANGING THE NUMBER OF BLADE AT DIFFERENT RPM OF IMPELLER

Anjusha Tiwari<sup>1</sup>, Prof. Kamal Kumar Jain<sup>2</sup>, Prof. Anshul Choudhary<sup>3</sup>, Dr.R.K Dave<sup>4</sup>.

<sup>1</sup>P.G student, SRIT, Jabalpur,(M.P) 482002

<sup>2</sup>Prof., Mechanical Dept, SRIT Jabalpur,(M.P)482002

<sup>3</sup>H.O.D, Mechanical Dept, SRIT , Jabalpur,(M.P)482002

<sup>4</sup>Prof., Mechanical Dept, SRIT Jabalpur,(M.P)482002

\*\*\*

**Abstract** - In the present work simulations for centrifugal pump were performed in order to give design improvements to the existing design of the pump. A centrifugal pump is common type of pump has been used in industry like sewage, drainage and chemical industry. Due to need of industrial requirements, the optimization of pump impeller has to be carried out in order to improve efficiency the head of pump.

A computational fluid dynamics (CFD) three dimensional simulation is done to optimize the pressure head, efficiency and power required of centrifugal pump by changing in impeller exit blade width, exit diameter, trailing edge blade angle.

In CFD analysis of the impeller, the head of pump is optimized to improve the performances of centrifugal pumps. Impeller is rotated for different revolution and mass flow rate. In this study initially the geometry of centrifugal pump impeller is created in Ansys blade gen design modeler and further mesh in Ansys turbo grid meshing tool and finally CFD analysis done in Ansys CFX.

In this study firstly the original dimensions of impeller taken from base paper [1] and by Changing the number of blades of the impeller and by varying the values of discharge at constant RPM the performance of impeller was checked by parameters Head, Power imparted to water by impeller and efficiency, from analysis it is found that as the number of blades of impeller increases the value of head and power imparted and the efficiency of impeller increases.

After that by keeping the number of blades as constant at different RPM of impeller the analysis has been performed and from analysis it is found that as the RPM of impeller increases the value of head and power imparted increase and the efficiency of impeller decreases.

**Key Words:** ANSYS CFX, CENTRIFUGAL PUMP IMPELLER, ANSYS BLAGEGEN , RPM, HEAD, POWER, EFFICIENCY.

## 1. INTRODUCTION

Centrifugal pumps are the most common type of pump used in industry, agriculture, municipal (water and wastewater plants), power generation plants, petroleum and many other industries.

Centrifugal pumps are the primary pump type in the class of pumps called "kinetic" pumps and are distinctly different than "positive displacement" pumps shown in Fig1.1 All centrifugal pumps include a shaft-driven impeller that rotates (usually at 1750 or 3500 RPM) inside a casing. Liquid flows into the suction port (inlet) of the casing and is thrown to the outside of the casing and then exits the discharge port. The velocity imparted to the liquid by the impeller is converted to pressure energy or "head".

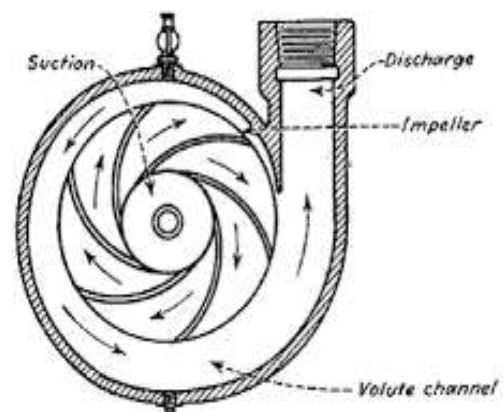

Figure 1.1: Centrifugal Pump.

Centrifugal pumps are unique because that can provide high or very high flow rates (much higher than most positive displacement pumps) and because their flow rate varies considerably with changes in the Total Dynamic Head (TDH) of the particular piping system. This allows the flow rate from centrifugal pumps to be "throttled" considerably with a simple valve placed into the discharge piping, without causing excessive pressure buildup in the piping or requiring a pressure relief valve.

Therefore, centrifugal pumps can cover a very wide range of liquid pumping applications.

### 1.2 MAIN PARTS OF CENTRIFUGAL PUMP

A centrifugal pump is a machine that uses rotation to impart velocity to a liquid, it then converts that velocity into flow. In that definition it can be seen that there are two things going on:

First, energy is being imparted to a liquid in the form of velocity. Second, that energy is converted into a steady flow.

Above discussion suggests that the centrifugal pump is composed of mainly two parts: the first being a rotating element consisting of an impeller and a shaft, and the second being a stationary element consisting of a casing, casing cover, and bearings. However, there are other components which complete a centrifugal pump assembly as shown in Figure 1.2:

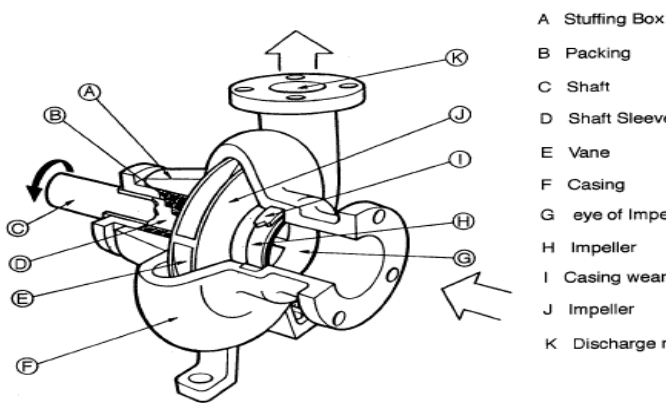

Figure 1.2-Main components of a closed-impeller centrifugal pump

#### (I) Impeller and Centrifugal Force

The rotating part of the centrifugal pump is called the 'impeller'. The impeller is a rotating disc with curved blades standing out vertically from the face of the disc.

The tips of the blades in the impeller are sometimes covered by another flat disc to give shrouded blades, otherwise the blade tips are left open and the casing of the pump itself forms the solid outer wall of the blade passage. The advantage of the shrouded blade is that flow is prevented from leaking across the blade tips from one passage to another.

The impeller is mounted on a shaft connected to the shaft of an electric motor. As the impeller rotates, the fluid that is drawn into the blade passages at the impeller inlet is accelerated as it is forced radially

outwards. In this way, the static pressure of fluid is raised.

#### (II) Casing

It is an air-tight passage surrounding the impeller which converts the K.E of water leaving the impeller into pressure energy before the water leaves the casing and enters the delivery pipe. The three commonly used casings are

**(a) Volute casing:-** Casing that surrounds the impeller, is of spiral type in which flow area increases gradually. The increase in area of flow, decreases the velocity of flow and thus increases the pressure of water. The efficiency of centrifugal pump having this casing is reduced due to the formation of eddies.

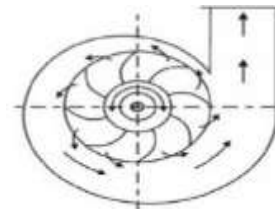

Figure 1.3: Volute Casing

**(b) Vortex casing:-** If a circular chamber is introduced between the casing and the impeller, then that casing is known as vortex casing. This considerably reduces the loss of energy due to the formation of eddies. Thus, the efficiency of the pump is more than the efficiency of volute casing centrifugal pump.

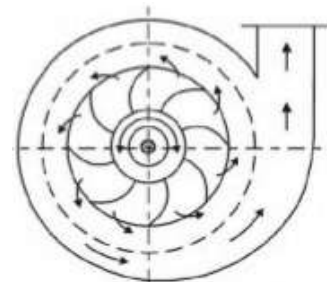

Figure 1.4: Vortex Casing

### 2.0 The objectives of the paper

A centrifugal pump is a common type of pump which has been used in industry like sewage, drainage and chemical industry. Due to the need of industrial requirements, the optimization of pump impeller has to be carried out in order to improve

- Efficiency of centrifugal Pump.
- Head of the Pump.
- Power imparted to water by impeller of Centrifugal Pump.

Centrifugal pumps are extensively used in the oil and gas industries and the impeller design parameters have Significant effect on the pump performance.

So in this study an impeller of centrifugal pump has been taken and by changing certain parameters of the geometry of impeller and the performance of centrifugal pump has been studied.

Firstly the impeller model has been taken from base paper [1] and check out the performance at different rpm of impeller by changing the number of blades in impeller to 6, 7, 8 and 9 all the models of impeller.

Following are the parameters which has been studied in this study, which are as following.

1. Changing the number of blades of the impeller and by varying the values of discharge at constant RPM the performance of impeller was checked.
2. Study the effect of varying the rpm of impeller by considering the number of blades of the impeller as constant.
3. The value of discharge varying from .1 to .14 and rpm of impeller were taken as 1323, 1470, 1617 and 1764.N

**3.0 METHODOLOGY**

In this study the blade of impeller has been designed by using the bladegen module the dimensions of the blade of impeller has been taken from base paper, below table1 showing the dimensions of the impeller blade and figure3.3 and 3.4 showing the Meridional configuration for impeller and complete model of the impeller.

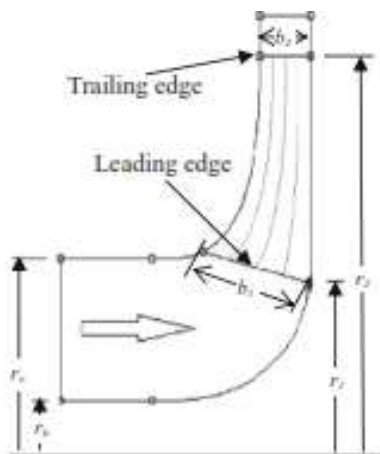

**Figure 3.3 Meridional configuration for impeller**

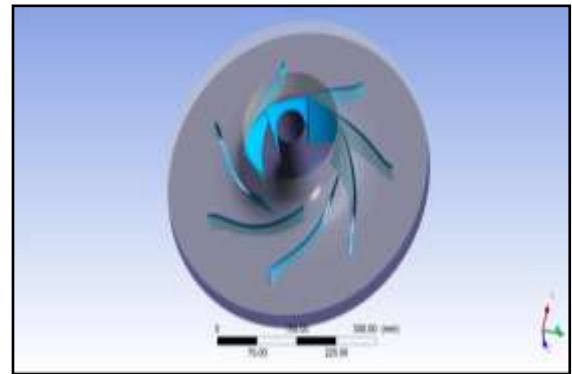

**Figure 3.4: Complete model of centrifugal impeller.**

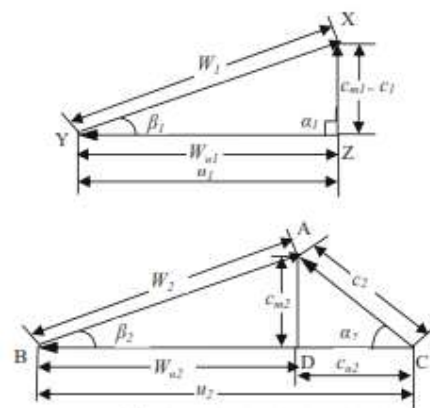

**Figure 3.5 Inlet and exit velocity triangle**

The dimensions above in the table are taken from the base paper and the performance of pump has been analysed by parameters like Head (H), Power imparted by impeller in water (P) and efficiency ( $\eta$ ).

The performance of impeller has been analysed by changing some parameter of impeller blade and then a final optimized model has been made by taking the best results obtained from each different cases considered.

Below table shows the different cases of impeller blade of centrifugal pump which has been studied.

**Table.3.2. Impeller width at exit**

<b>Case 1</b>				
<b>Number of impeller blade</b>	6	7	8	9

**Table.3.5. Impeller for optimized model**

<b>Case 2</b>				
<b>RPM of impeller</b>	1323	1470	1617	1764

The table above showing the modification which has been done in the existing blade of impeller. CAD modelling and meshing of the flow domain were carried out by using Ansys- BladeGen and –Turbo Grid module, respectively Ansys-CFX 16.0 was used for the flow simulations. The mesh in the flow passage was with O-grid block, and it was with H-grid block at the inlet and outlet. To achieve linear velocity distribution in the viscous sub layer, higher number of cells was employed near the wall. To avoid fine mesh inconsistencies and to resolve the boundary layer, at least 10 nodes were included into the boundary layer below figure 3.6 showing the meshing of complete impeller model. Default meshing method is used for meshing the geometry. It is meshed into 2, 33,100 nodes and 2, 12,355 elements as shown in Fig 3.6

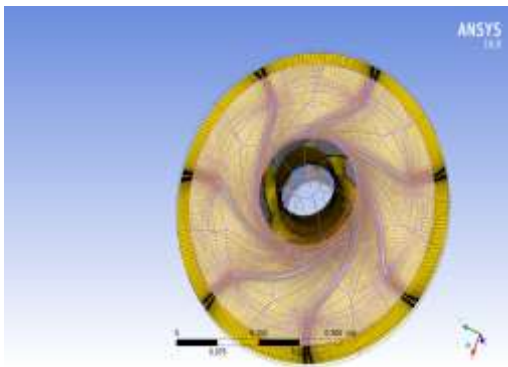

**Figure 3.6: The meshing model of impeller.**

**3.1 MATERIAL PROPERTIES**

For analyzing the performance of centrifugal pump in this research the water is used in fluid domain. The fluid properties of water has been given in table3.5 below from base paper.

**Table.3.5. Properties of water**

Sr. No.	PROPERTIES	VALUE
1	viscosity ( $\mu$ ) N s/m <sup>2</sup>	1.002e <sup>-3</sup>
2	Specific heat capacity (Cp) j/kg k	4181.7
3	Density ( $\rho$ ) kg/m <sup>3</sup>	997
4	Thermal conductivity (k) W/mk	0.6069

**3.2 BOUNDARY CONDITION**

The equations relating to fluid flow can be closed (numerically) by the specification of conditions on the external boundaries of a domain. It is the boundary conditions that produce different solutions for a given geometry and set of physical models. Hence, boundary conditions

Determine to a large extent the characteristics of the solution you obtain. Therefore, it is important to set boundary conditions that accurately reflect the real situation to enable you to obtain accurate results.

Boundary conditions are a set of properties or conditions on surfaces of domains, and are required to fully define the flow simulation. The type of boundary condition that can be set depends upon the bounding surface. A fluid boundary is an external surface of the fluid domain excluding surfaces where it meets other domains. A solid boundary is an external surface of the solid domain excluding surfaces where it meets other domains.

- A fluid-fluid interface is the interface between two fluid domains.
- A fluid-solid interface is the interface between a solid and fluid domain.
- A solid-solid interface is the interface between two solid domains.

The following boundary types are available in ANSYS CFX:

- Fluid Boundaries
- Solid Boundaries

Here in this research fluid-fluid interface is used to analyses the performance of impeller pump. Water has been used as the working fluid. The direction of the flow was defined normal to the boundary. Inlet velocity and temperature were specified. Outflow boundary condition was used at pressure-outlet boundary.

Pressure at inlet section of water is considered as 101353 Pa with inlet temperature of 288.15K. And at the outlet of the domain the mass flow rate has been changed ranges from 100-140 kg/s with the increment of 10 kg/s. below figure 3.7 showing the model with boundary conditions.

Table 3.6 Boundary conditions

1	Inlet condition	101353 Pa
2	Outlet condition for inlet fluid mass flow rate (Kg/s)	100-140 kg/s with the increment of 10 kg/s.
3	Outlet condition for inlet fluid Discharge ( $Q_0$ m <sup>3</sup> /s)	0.1-0.14
4	Inlet temperature ( $T_{in}$ )	288.15 K
5	RPM of impeller N (rpm)	1323, 1470, 1617 and 1764

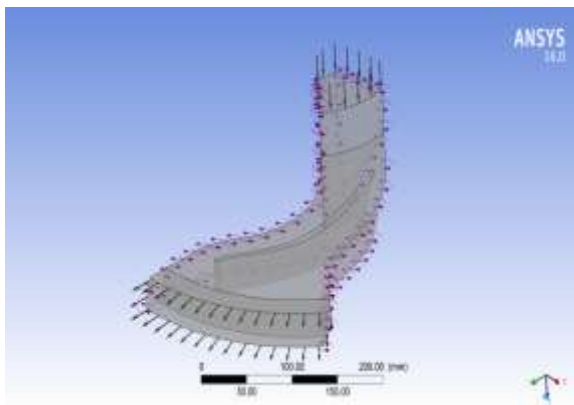

Figure 3.7 Impeller with applying boundary condition.

#### 4.0 RESULTS AND DISCUSSION

##### 4.1 GRAPHS SHOWING VARIATION OF HEAD, POWER AND EFFICIENCY OF IMPELLER BY CHANGING NUMBER OF BLADES AT CONSTANT RPM.

Here in this section firstly the comparisons have been made between pump impellers having different number of blades (6, 7, 8 and 9) by considered the same rpm. Flow rate is the fixed parameter in every graph and variations of other parameter Head, efficiency and power were discussed.

In this section the variation of head, power and efficiency had been studied with respect to different values of discharge by changing different numbers of blades of impeller.

##### 4.1.1 Head Variation at different numbers of blade with rpm of 1470 w.r.t discharge Q

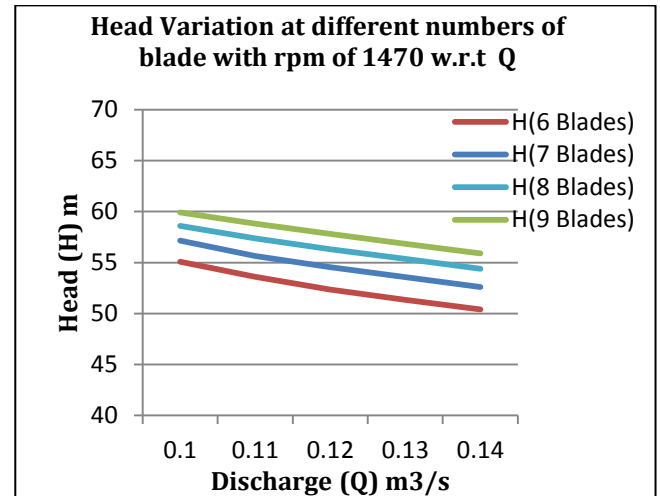

Graph 4.1: Head Variation at different numbers of blade with rpm of 1470 w.r.t discharge Q

From above graph it is clearly seen that as the number of blades of impeller increases the Head also increases for every values of discharge and it is also found that as the value of discharge increases on any number of impeller blades the Head decreases.

##### 4.1.2 Power imparted by impeller on water at different numbers of blade with rpm of 1470 w.r.t discharge Q

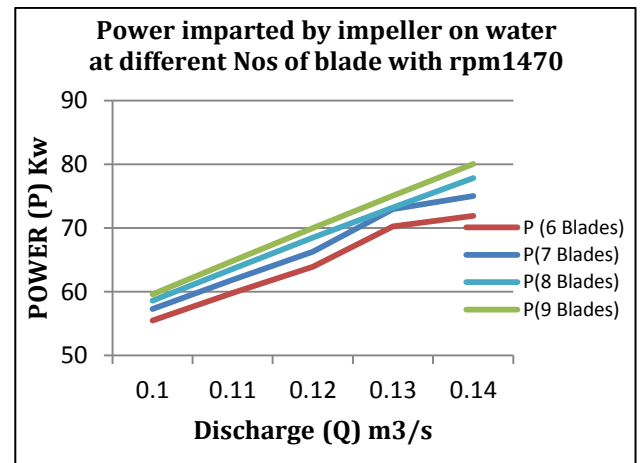

Graph 4.2: Power imparted by impeller on water at different numbers of blade with rpm of 1470 w.r.t discharge Q

Above graph shows that as the number of blades of impeller increases the Power imparted by impeller on water (P) also increases for every values of discharge and it is also found that as the value of discharge increases on any impeller the power also increases.

#### 4.1.3 Efficiency of pump impeller at different numbers of blade with rpm of 1470 w.r.t discharge Q

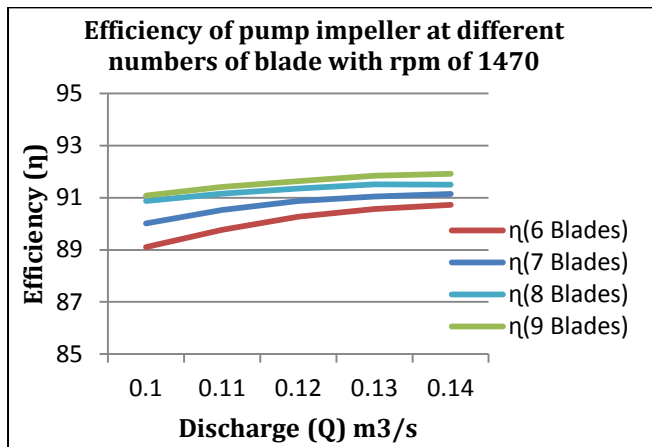

Graph 4.3: Efficiency of pump impeller at different numbers of blade with rpm of 1470 w.r.t discharge Q

From above graph it is seen that as the number of blade of impeller increases the efficiency of impeller pump also increase for every values of discharge and it is also found that as the value of discharge increases on any impeller the efficiency also increases.

#### 4.2 VARIATION OF HEAD, POWER AND EFFICIENCY OF IMPELLER BY CHANGING RPM AT CONSTANT NUMBER OF IMPELLER BLADE.

Here in this section the comparisons have been made between pump impellers having 7 number of blades by considered the different rpm of impeller. Flow rate is the fixed parameter in every graph and variations of other parameter Head, efficiency and power are discussed.

##### 4.2.1 Head Variation at different rpm of impeller have 7 number of blades.

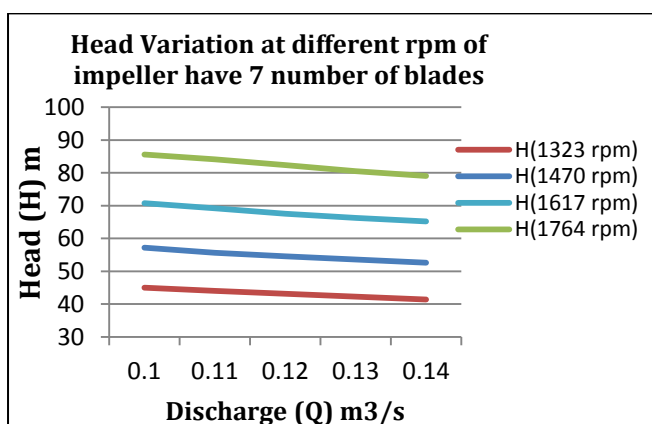

Graph 5.16: Head Variation at different rpm of impeller have 7 number of blades

From above graph it is clearly seen that as the rpm of impeller increases the Head also increases for

every values of discharge and it is also found that as the value of discharge increases on any rpm of impeller blades the Head decreases.

##### 4.2.2 Power imparted by impeller on water at different rpm of impeller have 7 number of blades.

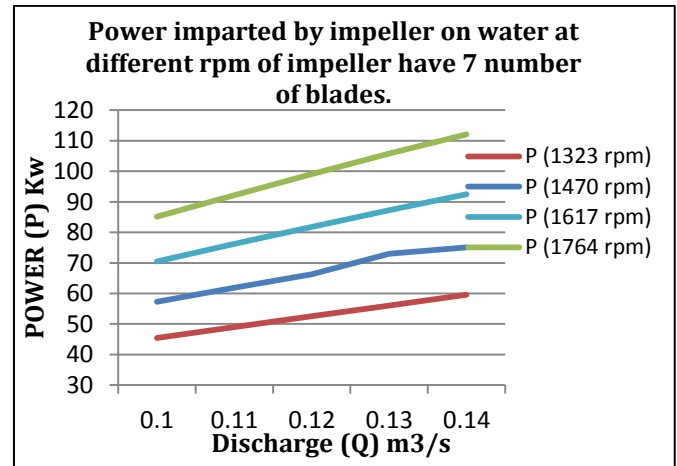

Graph 4.5: Power imparted by impeller on water at different rpm of impeller have 7 number of blades.

Above it is clearly seen that as the rpm of impeller increases the Power imparted by impeller on water (P) also increases for every values of discharge and it is also found that as the value of discharge increases on any rpm of impeller blades the power also increases.

##### 4.2.3 Efficiency of pump impeller at different rpm of impeller have 7 number of blades.

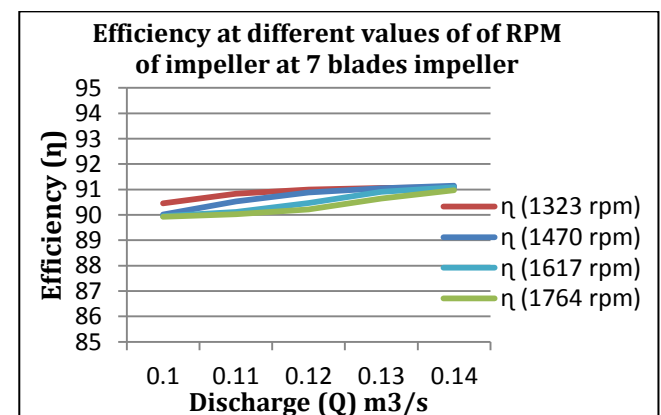

Graph 4.6: Efficiency of pump impeller at different rpm of impeller have 7 number of blades.

From above graph it is found that as the rpm of impeller increases the efficiency of impeller pump decreases for every values of discharge and it is also found that as the value of discharge increases on any rpm of impeller the efficiency also increases.

## 5.0 FINAL CONCLUSION.

Followings are the conclusion which have been found from study.

- As the number of blades of the impeller increases the values of head also increases in every values of RPM of impeller.
- As the value of number of blades of the impeller increases the values of power imparted by the impeller to water also increases in every values of RPM of impeller.
- As the value of number of blades of the impeller increases the values of efficiency also increases in every values of RPM of impeller.
- If the same number of impeller blade model has been checked at different RPM it is found that the value of head and power increases but the value of efficiency decreases.

## 6.0 REFERENCES

- [1] Sayed Ahmed, Imran Bellary and Abdus Samad, "Pumping crude oil by centrifugal impeller having different blade angles and surface roughness" J Petrol Explore Prod Techno (2016) 6:117-127 ,DOI 10.1007/s13202-015-0173-y Published online: 9 June 2015.
- [2] Seralathan S, Roy Chowdhury D G."Modification of centrifugal impeller and effect of impeller extended shrouds on centrifugal compressor performance "Research Scholar, Department of Mechanical Engineering, HITS, Hindustan University, Padur 603 103.
- [3] Seralathan S, Roy Chowdhury D."Free rotating vane less diffuser of diffuser diameter ratio 1.30with different speed ratios and its effect on centrifugal compressor performance improvement". Department of Mechanical Engineering, Hindustan Institute of Technology and Science, Padur 603 103, Tamilnadu, India.
- [4] Alex George and Dr. P Muthu. "Cfd analysis of performance characteristics of centrifugal pump impeller to minimizing cavitation". International Conference on Current Research in Engineering Science and Technology (ICCREST-2016).
- [5] Satish M.Rajmane and Dr.S.P.Kallurkar."Cfd analysis of domestic centrifugal pump for performance enhancement". International Research Journal of Engineering and Technology (IRJET), e-ISSN: 2395-0056/ Volume: 02 Issue: 02 | May-2015.
- [6] P.Gurupranesh, R.C.Radha and N.Karthikeyan."Cfd analysis of centrifugal pump impeller for performance enhancement".IOSR Journal of Mechanical and Civil Engineering (IOSR-JMCE) e-ISSN: 2278-1684, p-ISSN: 2320-334X PP 33-41.
- [7] P.ArunKumar, P.Dhachinamoorthi, K.Saravanakumar and S.Venkatesh."Analysis and investigation of centrifugal pump impellers using cfd".IRACST – Engineering Science and Technology: An International Journal (ESTIJ), ISSN: 2250-3498 Vol.4, No.4, August 2014.
- [8] Atiq Ur Rehman, Sub hash Shinde, akshoyranjan Paul and Anuj Jain." Effects of discharge on the performance of an industrial centrifugal pump" Proceedings of 2015 International Conference on Computing Techniques and Mechanical Engineering (ICCTME'2015) Phuket, October 1-3 2015, pp. 24-32
- [9] A Manivannan."Computational fluid dynamics analysis of a mixed flow pump impeller" International Journal of Engineering, Science and Technology Vol. 2, No. 6, 2010, pp.200-206.
- [10] Satish M. Rajmane and Dr. S. P. Kallurkar."Flow distribution network analysis for discharge side of centrifugal pump"Novateur Publications, International Journal of Innovations in Engineering Research andTechnology [Ijiert] Issn: 2394-3696 Volume 2, Issue 7, July-2015.
- [11] Narayan P. Jaiswal. "Cfd analysis of centrifugal pump: a review" Int. Journal of Engineering Research and Applications.ISSN: 2248-9622, Vol. 4, Issue 5(Version 6), May 2014, pp.175-178.
- [12] Dr. S B Prakash, Ajay Bhardwaj M." Cfd analysis of a radiator pump to investigate the cause and to eliminate the unwanted vibrations" International Journal of Research Studies in Science, Engineering and Technology Volume 1, Issue 5, August 2014, PP 52-59 ,ISSN 2349-4751 (Print) & ISSN 2349-476X.
- [13] "Analysis of effects of impeller inlet width on the performance of centrifugal pump". Journal of Chemical and Pharmaceutical Research, 2014, 6(5):2078-2081 ISSN: 0975-7384CODEN (USA): JCPRC5., 2015, pp.290-294.