

# VEHICLE TRACKING SYSTEM USING GPS-GSM TECHNOLOGY

Peter .O. Ohiero<sup>1</sup>, Julius .U. Ukang<sup>2</sup>, Okpogo, Ota Ota<sup>3</sup>

<sup>1,2</sup>Lecturer, Department of Electrical and Electronic Engineering, Cross River University of Technology, Calabar, Nigeria

<sup>3</sup>Student, Department of Electrical and Electronic Engineering, Cross River University of Technology, Calabar, Nigeria

\*\*\*

**Abstract** - This project presents a vehicle tracking system using GPS-GSM technology that can be remotely monitored by a GSM phone. It is designed to track the position of a vehicle at any period of time. It comprises of a GPS receiver, a microcontroller and a GSM module. The combination of these technologies produces a tracking system. The GPS continuously takes input data from the satellite and stores the latitude and longitude values in a PIC16F72 microcontroller's buffer. This basically means that if a person has to track a vehicle, a message has to be sent to a GSM device, by which it gets activated. The location of the vehicle is identified using global positioning system (GPS) and global system for mobile communication (GSM). These systems constantly watch a moving vehicle and report the status on demand. When theft is identified, the owner sends an SMS to the microcontroller and the microcontroller sends back a message containing the location of the vehicle in terms of latitude, longitude and time.

**Key Words:** Vehicle tracking security, GPS, GSM, SMS, microcontroller.

## 1. INTRODUCTION

The rising cases of vehicle theft, vehicle hijack, kidnapping, diversion of crude oil and petrol, change of route by drivers of transport companies and theft of valuable containers and items in sea ports have necessitated the use of a more reliable security system in vehicles and storage facilities for valuable items. A security system that can track, monitor and give feedback of the location of the vehicle or container.

Several technologies have been developed to provide reliable security for vehicles and valuable goods. Some of the technologies are locking systems such as the steering wheel lock, central locking systems, theft detection systems, fuel and ignition disabling system, etc. all these can reduce the possibility of vehicle been stolen but can easily be manipulated by the thief and does not give a trace or location of the vehicle or goods if the vehicle is eventually stolen. Several researchers and companies have designed and constructed vehicle monitoring and tracking device [1][2][3][4]. Many of them are microcontroller based system.

There are the 8051 and the PICs microcontroller. The 8051 is an 8-bit controllers with different input/output (I/O) features that are part the 8051 core which requires lesser hardware for its functions. It has only one 16 bit

pointer register and does not have an internal Analogue to Digital Converter (ADC), which are major drawbacks of the 8051 core. This makes it difficult to move a block of data. On the other hand the PICs has an advanced level of A/D applications, it is fast, easy to program and interface with other peripherals and low power consumption suitable for automobile applications, the reason it is used in this project.

The vehicle tracking system presented here is a vehicle theft or location change monitoring and tracking system that gives information on demand of the new location of vehicle. This system is suitable for vehicle owners, school buses, transport business companies, fleet management, crude oil and petrol tankers owners etc. It consists of small electronic unit which is fixed in a hidden place in the vehicle to monitor the location of the vehicle. It is fixed in the vehicle in such a manner that it is not visible to anyone who is inside or outside the vehicle except the owner of the vehicle or the company that installed it. After installation, the system will locate target by the use of a web application (HTML based application) in Google map. When the vehicle changes location or is stolen, the GPS module (receiver) in the device receives information about the location (coordinates) from the GPS satellites and transmits data to the microcontroller. The GSM modem provided with a registered SIM card receives the GPS parameters of latitude, longitude and time from the microcontroller. The Exact location of the vehicle is indicated in the form of latitude and longitude along with the exact navigated track on Google map. The arrived data, in the form of latitude and longitude is used to locate the vehicle on Google maps, the output is then displayed on the LCD and transmits to the vehicle owner mobile phone in the form of SMS when request is made. This system is user friendly, easily installable, easily accessible and can be used for various other purposes. The system is not limited to find the location of the target but also calculates the distance travelled between two stations.

## 2. DESCRIPTION OF THE PROPOSED SYSTEM

The vehicle tracking system we designed and implemented consists of different modules to make a complete system. Each of the module consists of electronic components that are put together. The block diagram of the vehicle tracking system is shown in Fig. 1, which practically shows the overall view of the system. It consists of GPS module, GSM modem, microcontroller PIC16F72, LCD display and power supply

unit. The microcontroller PIC16F72 is the central processing unit that is programmed to controls the operation of other modules.

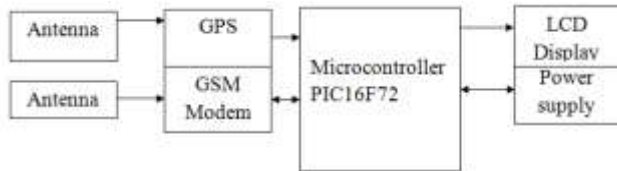

Fig-1: Block diagram of vehicle tracking system

The system is designed in such a way that it continuously monitors a moving vehicle and report the status of the vehicle on demand. For this to be achieved, a microcontroller is interfaced serially to a GSM Modem and GPS Receiver. A GSM modem is used to send the position of the vehicle from a remote place. The GPS module will continuously give the data i.e. the latitude and longitude indicating the position of the vehicle. The hardware interfaces to microcontroller are LCD display, GSM modem, power supply, GPS Receiver and motor.

Fig. 2 shows the circuit diagram of the system. The compact circuitry is built around a PIC16F72 microcontroller. A 30MHz quartz crystal oscillator is connected to pin 9 and 10 of the microcontroller which provides basic clock frequencies to the microcontroller. GPS uses satellites and devices or receivers to determine an exact location on earth. In this project we use active GPS that transmit information to the PIC16F72 microcontroller thereby providing real time information on the LCD 16x2 display.

The power supply section is extremely important for all electronic circuits. A regulated 5V, 500 mA and 12V, 500 mA is provided using a three terminal voltage regulator IC LM7805. The output of the regulator which is +5V is connected to VDD of the LCD and as well pin 1 of the microcontroller, VSS of the LCD is looped to VEE and connected to ground (GND) as well as the ground terminal of the voltage regulator. A power supply of 5V is connected to GPS modem through pin 1 which directly goes to the output of the voltage regulator (LM7805). The input of the regulator being 12VDC without regulation is fed to the GSM receiver through pin 11 of the microcontroller. Register select (RS) which selects command register when low; and data register when high is connected to pin 2 of the microcontroller. Enable (E) of the LCD which sends data to data pins when a high to low pulse is given is connected to pin 2 of the microcontroller. DB 4, 5, 6, 7 which are data pins of the LCD are connected to the output pins 24, 25, 27, 28 of the microcontroller. 12V and 5V power supply were chosen because GSM modules uses 12V and GPS modules uses 5V supply. The main function of the microcontroller is to invert analogue signal from GSM/ GPS module to digital signals for real time display on the LCD.

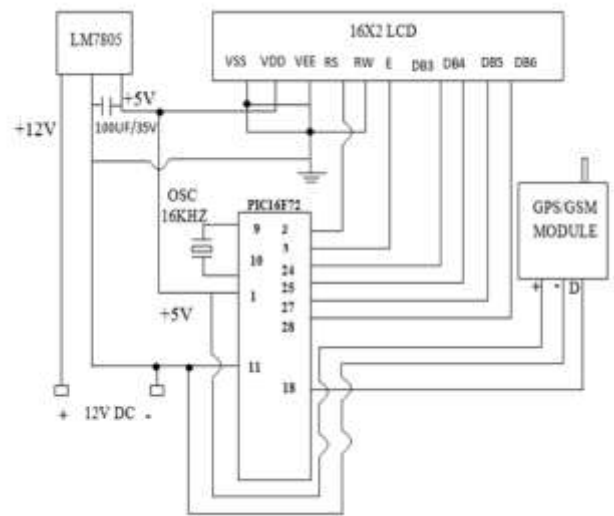

Fig-2: Circuit diagram of a vehicle tracking system

### 3. OPERATION

Whenever a vehicle is parked, it is kept at vehicle tracking security mode. Once the vehicle is stolen, the position of the vehicle changes, the owner can send an SMS to the vehicle to know the location or position of the vehicle. The SMS sent would pass through the GSM service provider and then reach the vehicle, which is travelling, because the vehicle has a GSM device with a SIM card. This GSM modem will receive the SMS and send to the microcontroller in the vehicle. The microcontroller will receive this SMS and compare the password and the command. If the information matches the already programmed one, then it will perform the request required by the owner. It will then send the required location; latitude, longitude and time to the registered number of the owner and the results will be display on the screen of the owner’s mobile phone. The owner can then send a message to stop the engine of the vehicle.

### 4. SOFTWARE REQUIREMENT

In this project, Proteus software was used for both the simulation and the PCB design while the Arduino compiler were used to program and compile the microcontroller.

The Arduino IDE is a cross-platform application written in Java, and is derived from the IDE for the processing programming language and the wiring project. It is designed to introduce programming to artists and other beginners that have little knowledge of software development. It includes a code editor with features such as syntax highlighting, brace matching, and automatic indentation [5], and is also capable of compiling and uploading programs to the board with a single click. The Arduino IDE comes with a C/C++ library called "Wiring", which makes many common input/output operations much easier [6].

### 5. TESTING AND OPERATION

Fig. 3 shows the assembling of the different modules of the proposed vehicle tracking system and Fig 4 shows the completely cased system. In testing, we fixed the completed vehicle tracking device in a car as shown in Fig. 4 and allow the car to be driven away to a different location. We then send an SMS with a registered mobile phone to the GSM modem with a registered SIM card with a command "TRACK VEHICLE" and an SMS was received by the mobile phone. The SMS gave the latitude, longitude and time as shown in Fig. 5.



Fig-3: Image of the complete system assembly with LCD showing the position of the vehicle



Fig - 4: Image of the complete system assembly with LCD showing the location of the vehicle

### 6. RESULTS AND DISCUSSION

The vehicle tracking system works mainly by receiving messages from a mobile phone. There is a message command by which we can track the vehicle. And this command is to send an SMS; "TRACK VEHICLE" to the registered SIM card number in the GSM modem. This command initiates the GPS modem and receives the latitude and longitude position and this information will then be sent as SMS to the mobile device. Whenever theft occurs or on demand request of the vehicles location, the device sends a message to the vehicle owner's mobile device as shown on the mobile phone screen in Fig. 5 as follows:

#### Vehicle tracking alert:

Your vehicle current location is:

Latitude: 0455.73335

Longitude: 00819.81980

Please take some action soon... Thank you

This system shows the location of vehicle on the LCD connected to it to ensure the working condition of the microcontroller.



Fig-5: Owner's mobile phone Screenshot of returned SMS to a TRACK VEHICLE request





**Fig-6:** Google map location of the vehicle and tracking system

- [2] S. Boopathi, K. Govindaraju, M. Sangeetha, M. Jagadeeshraja, M. Dhanasu "Real Time Based Smart Vehicle Monitoring and Alert Using GSM" International Journal of Advanced Research in Computer and Communication Engineering Vol. 3, Issue 11, November 2014, ISSN (Online): 2278-1021, ISSN (Print): 2319-5940.
- [3] Kunal Maurya , Mandeep Singh, Neelu Jain, "Real Time Vehicle Tracking System using GSM and GPS Technology- An Anti-theft Tracking System", International Journal of Electronics and Computer Science Engineering, ISSN 2277-1956/V1N3-1103-1107.
- [4] Lu Mai, Min Zaw O "Design and Construction of Microcontroller Based Wireless Remote Controlled Industrial Electrical Appliances Using ZigBee Technology", International Journal of Scientific Research Engineering & Technology (IJSRET), ISSN 2278 - 0882, Volume 3 Issue 1, pp. 79 - 84, April 2014.
- [5] Daniel. W. Lewis, "Fundamental of embedded software", prentice hall of India, 2004.
- [6] Alan G. Smith, "Introduction to Arduino: A piece of cake!" ISBN: 1463698348, ISBN-13: 978-1463698348, <http://www.introtoarduino.com>

## 7. CONCLUSION

We have successfully developed and implemented a vehicle tracking system that gives feedback information of the location of stolen vehicle using GPS-GSM technology. It is user friendly, easily installable, easily accessible and can be used for various other purposes. The system is not limited to find the location of the target but also calculates the distance travelled between two stations. It can also be applied for better management of fleet with a return of large profit, better scheduling or route planning to enable large job schedule. If this project is properly implemented it will improve safety, reduce vehicle loss due to theft, increase productivity, reduce diversion of routes by transport company's drivers. We are still working on the possibility of improving on the system to give SMS feedback to the vehicle owner when an accident occurs. This will help to reduce the delay in evacuation of accident victims to hospital and reduce the chances of losing life.

## REFERENCE

- [1] K.S. Alli, C. Ijeh-Ogboi and S.L. Gbadamosi "Design and Construction of a remotely controlled vehicle anti-theft system via GSM network" International Journal of Education and Research vol. 3 No. 5 May 2015.