

# Experimental Study on Effect of Metallic Oxides Mixture on Tribological Behaviour of Aluminum Based Metal Matrix Composites

Lokesh KS<sup>1</sup>, Dr.Thomas Pinto<sup>2</sup>

<sup>1</sup>Assistant Professor, Department of Mechanical Engineering, Srinivas Institute of Technology, Karnataka, India

<sup>2</sup> Professor, Department of Mechanical Engineering, Srinivas Institute of Technology, Karnataka, India

\*\*\*

**Abstract** - Use of naturally available, economically viable with greater abundance of internal constituents defines the natural ceramic particles invites the investigation proposals to evaluate and characterize when effectively merged with metals which weighs lighter and exhibits better strength. The demand for light weight and high strength materials for structural and tribological applications aims to develop new age materials to full fill the need of various commercial aspects including easy of processing techniques. Metals like aluminum with variety of grades acts as matrix to access the minute particles exhibits huge benefits once made by most convenient techniques to term them as metal matrix conjugates. Red mud emerges as the major waste material during production of alumina from bauxite by the Bayer's process. It comprises of oxides of iron, titanium, aluminium and silica long with some other minor constituents. Based on economics as well as environmental related issues, enormous efforts have been directed worldwide towards red mud management issues i.e. of utilization, storage and disposal. Different avenues of red mud utilization are more or less known but none of them have so far proved to be economically viable. Tribological properties are improved remarkably by introducing hard intermetallic compound into the aluminium matrix. The reinforcing materials are generally contain Silicon carbide, alumina as constituents which are costly to inculcate as a major part so that introducing this composition in aluminium matrix leads to property enhancement for the prepared metal matrix composites. keeping this aspect in mind the present research aim is to explore the use of red mud as a reinforcing material which build with the composition of  $\text{SiO}_2$ ,  $\text{Al}_2\text{O}_3$  as well as low cost option when used with aluminium. Samples are prepared by stir casting technique. Castings are cut, turned and shaped into the required size to prepare the specimens for evaluation of wear resistance of samples by employing pin-on-disc apparatus. It is observed that the inclusion of the red mud is drastically affecting the friction resistance and frequent wear of the composites. The increase of the red mud particles by weight percentage has decreased the wear resistance as these samples have greater susceptibility to abrasive resistance indicating the most suitable for light weight and tribological applications.

**Key Words:** Metallic oxide mixtures, Al203/Al light weight structures, Advanced MMC's

## 1. INTRODUCTION

Metal matrix composite materials have found application in many areas of daily life often which is not realized that the application make use of composite materials. These materials are produced in situ from the conventional production and processing of metals [1]. Aluminium alloys are preferred engineering material for automobile, aerospace and mineral processing industries for various high performing components that are being used for varieties of applications; owing to their lower weight and excellent thermal conductivity properties. Among several series of aluminium alloys, heat treatable Al6061 and Al7075 are much explored, among them Al6061 alloy are highly corrosion resistant, exhibits moderate strength and finds much applications in the fields of construction, automotive and marine applications. Due to their high strength, fracture toughness, wear resistance and stiffness, these metals stand high in interest. Further these composites are of superior in nature for elevated temperature application when reinforced with ceramic particle. Process parameters plays a vital role on properties of Al based MMC. There are several processes are there for production of metal matrix composites, stir casting is one of the most convenient method where process parameters are regulated with most effective way. In case of Stir casting, process parameters like stirring rate, stirring temperature, pouring temperature to be maintained for achieving better properties of MMC's [2]. Tribological studies and other mechanical properties evaluation of the above produced MMCs can also be investigated [3]. Waste material like fly powder and rice husk fiery remains are used in 5 to 15 % then acquire the composite material which have great wear, erosion and warmth protection properties [4]. Addition to this use of graphene powder is used as a reinforced material in aluminum matrix is observed to enhance hardenability of aluminum. It is noticed that Graphene particles improves hardenability of soft matrix bearing more load and records 78RHN as compared to the parental composition [5]. Aluminium matrix is getting strengthened when it is reinforced with the hard ceramic particles like Silicon carbide, Aluminium oxide and Boron carbide etc [6]. This present work highlights Develop a standardized process of stir casting process to synthesize red mud composites by utilising Al6061 with red mud particles as reinforcement and study experimentally the wear resistance of Al6061-red mud composites by added with different percentage by weight proportion.

## 2. MATERIALS & METHODOLOGY

Bellow discussion highlights the empirical view of effective utilization of constituent materials and devices for the successful finishing of red mud based aluminum based metal matrix composites.

### 2.1 Red mud as Reinforcement

Red mud emerges as the major waste material during production of alumina from bauxite by the Bayer’s process. It comprises of oxides of iron, titanium, aluminium and silica along with some other minor constituents [7]. Based on economics as well as environmental related issues, enormous efforts have been directed worldwide towards red mud management issues i.e. of utilization, storage and disposal. Different avenues of red mud utilization are more or less known but none of them have so far proved to be economically viable or commercially stable [8]. In India, about 4.71 million produced which is 6.25% of world’s total generation. It is the insoluble product after bauxite digestion with sodium hydroxide at elevated temperature and pressure. It is a mixture of compounds originally present in the parent mineral bauxite and of compounds formed or introduced during the Bayer cycle [9]. It is disposed as slurry having a solid concentration in the range of 10-30%, pH in the range of 10-13 and high ionic strength.

**Table.1 Chemical Constituent of Red mud**

Chemical Constituent	Fe2 O3	Al2O3	SiO2	CaO	Na2O	TiO2
Percentage	30-60%	10-20%	3-50%	2-8%	2-10%	25%

**Table.2 Physical Properties of Red mud**

Properties	Values
Maximum dry Density (g/cc)	1.53
Optimum moisture Content (%)	31
Specific Gravity	2.85
Liquid Limit (%)	40
Cohesion (kg/cm <sup>2</sup> )	0.125

Raw red mud which is collected before and after sieving is as shown in figure.1



(a) Before sieve (b) After sieve

**Figure.1 Red mud**



**Figure.2 150 microns sieve**

### 2.2 Matrix Material

For the present investigation aluminum 6061 which is as shown in fig.3 was used as a matrix material which is heat treatable and extrudable alloy which is widely used in commercially and chemical composition and major properties of aluminum 6061 are shown in table 3&4 respectively.

**Table.3 Chemical composition of Al-6061**

Component	Al	Mg	Si	Fe	Cu	Zn	Ti	Mn	Cr
Amount	Rest	0.84	0.62	0.23	0.22	0.1	0.1	0.03	0.22



**Fig.3 Aluminium-6061**

**Table .4 Important properties of Al-6061**

Properties	Value
Density:	2.7 g/cm <sup>3</sup>
Modulus of Elasticity: 70-80 GPa	70-80GPa
Ultimate Tensile strength (Mpa)	110-152
BHN(500kg,10mm ball)	30-33
Melting Point	580 <sup>o</sup> c

### 2.3 Stir Casting Technique;

#### Chemicals used;

#### Exo-chloro ethane:

It is in tablet form. The exachloroethene is shown in fig.4 which is used to degas the material



**Figure.4 Exo-chloroethane**

#### Coverall:

It is in powder form which is shown in fig.5 which is used to remove the impurities and slag and also to increase oxidation resistance. Coverall is significantly used to increase the wettability



**Figure.5 Coverall in powder form**

#### Magnesium Chips:

It is in crystal form which is normally used to increase the wettability. If magnesium content increases more than 0.5% porosity will form, magnesium chips is as shown in fig.6



**Figure.6 Magnesium chips**

**Components used:**

**Die:**

The die used (as shown in fig.7) for the stir casting process is hollow cylinder. Where the diameter of the die is 25mm and the length is 150mm



**Figure.7 Die**

**Crucible:**

The thickness of the crucible (shown in fig.8) used in the stir casting process is 15mm



**Figure.8 Crucible**

**Furnace:**

The material used for the furnace (as shown in fig.9) is silicon carbide



**Figure.9 Furnace**

**Pre-heater:**

The pre-heater (fig.10), the pre-heating temperature of the mould is 400-500 deg Celsius. The material used for the mould is OHNS



**Figure.10 Pre-heater**

**Specimen preparation:**

Aluminum reinforced MMC is prepared by stir cast process. In this study, Al-6061 is used as matrix material with different % of red mud. Measured quantity of Al 6061 and red mud particles required to produce composites are 0%, 2%, 4%, 6% and 8% by weight composition of aluminum the specimen preparation by pouring molten aluminum to suitable die arrangement followed by mixing of red mud particles and allowed the mixture to cool down to room temperature which is as shown in fig.11. The process parameters were kept same for all the composition of MMC samples.



**Figure.11 Stirring of red mud particles with molten Al6061**

Ceramic particles are heating up to preheating temperature for every sample. Then 1000 grams of aluminum 6061 is weighed for every sample and kept in the crucible until it melts. Later the chemicals like exachloroethane, Cover all, Magnesium chips are added to the composition because to degas the material and increase wet ability. After adding all chemicals, red mud is added to the aluminum and stirring the composition which allows the proper distribution of particles. After the mixture of aluminum and red mud is poured to die which is in liquid state and waited for 1hr to cool and then sample is removed from the die assembly and specimen is obtained. Fig.12 depicts the sample preparation setup where required composition of metal matrix composites are obtained.

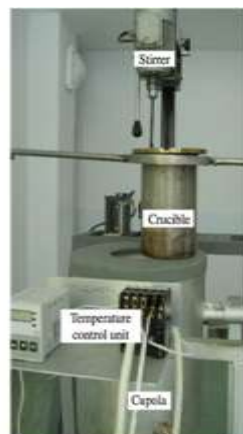
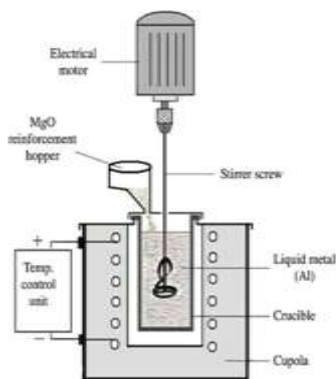

**Figure.12 Specimen preparation**

### 3. EXPERIMENTATION

#### WEAR TESTING

##### 3.1 SLIDING WEAR:

Wear is a loss or redistribution of surface material from its intended location by the definition of the ASTM. As the wear is a surface removal phenomenon and occurs mostly at outer surfaces, it is more appropriate and economical to make surface modification of exiting alloys than using the wear resistant alloys. Dry sliding wear tests for different numbers of specimens were conducted by using pinon-disc apparatus shown in figure 13. The pin was held against the counter face of a rotating disc (EN31 steel disc) with wear track diameter 100mm. The pin was loaded against the disc through a dead weight loading system.

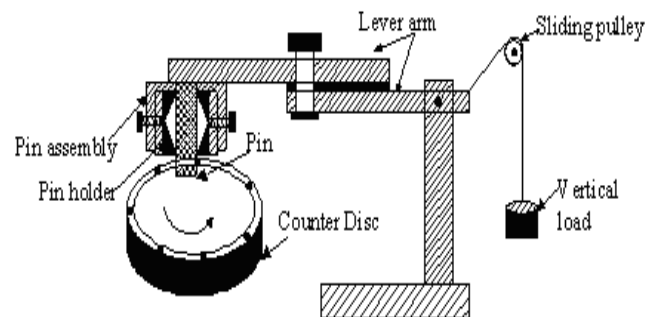

**Figure.13 Pin-on disc apparatus**

The wear test for all specimens was conducted under a fixed sliding velocity of 1.6m/s. Wear tests were carried out for a total sliding distance of approximately 1600m under similar conditions as discussed above. The pin samples were 50mm in length and 6mm in diameter. The samples and wear track were cleaned and weighed (up to an accuracy of 0.001gm using microbalance) prior to and after each test . The wear rate was calculated from the height loss techniques and expressed in terms of wear volume per unit sliding distance. Wear tester and temperature friction monitor device is as shown in figure 14(a) & (b) respectively.



(a)



(b)

**Figure.14 (a) Pin on disc apparatus (b)Temperature & friction monitor device**

**Machine specification**

- Wear disc diameter 165 mm
- Material: En 31 hardened to 60 HRC/1.6Ra
- Disc speed: Minimum 200 rpm & Maximum 2000 rpm
- Normal load : Minimum 5 N & Maximum 200 N
- Frictional force: Maximum 200 N & Minimum 1K
- Wear thickness 0 to 200 micron
- Temperature range: Ambient to 400 °c pin heating.

Experimentation was done on the significant parameters like speed, load and time where speed and time are kept different for conducting the test.

**4. RESULTS AND DISCUSSIONS**

Based on obtained results it is clearly noted that the inclusion of the red mud is drastically affecting the micro structure of the of the composite prepared. The fig Figure.15 highlights the amount of wear loss incurred against applied load.

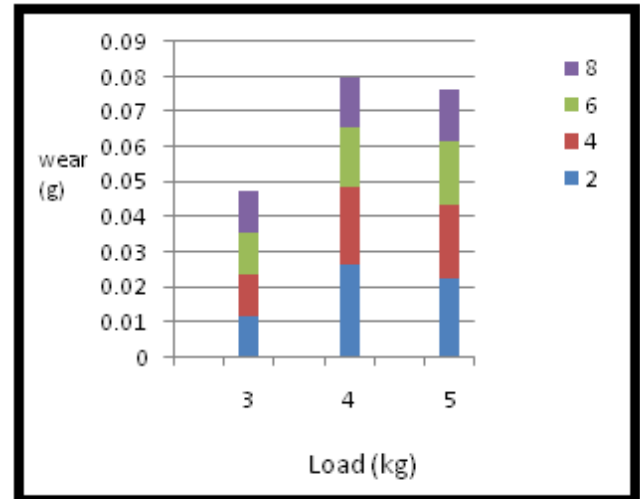

Figure.15 Wear loss v/s Load applied

It is clearly noticed that there will be consistent resistance offered by a material against least applied when it is subjected to wear mechanism whereas the amount of load increases progressively increases the wear rate. At the same time samples containing different percentage of red mud particles measures variations in responding against the wear occurred at the outer surface as weight of the red mud particles increases which gradually decreases the wear loss which reveals that optimum resistance was observed for each corresponding increase of the load i.e 3,4,5kg with respect to the increase in composition of red mud i.e 2,4,6,8% by weight . This is because the intentional impurities added confines the distortion of the lattice structure by foreign grains with specific size distributed within the regular arrangement of parent matrix leading to significant resistance to wear mechanism. The sudden increase of the load may cause progressive loss of the material but increasing the rate of distortion by adding red mud particles significantly decreases the wear loss and this trend continues up to maximum load applied and noticed from the graph that the samples containing 8% of red mud shows optimum resistance to wear compare to the rest of the samples thereby concluding that samples containing higher amount of red mud particles significantly improves the wear resistance of the base material.

## 5. CONCLUSIONS

Aluminium based metal matrix composites with iron oxide, silica and alumina inclusions with different weight percentage of 2%,4%,6%,8% have been prepared successfully by adopting stir casting technique. Uniform distribution of red mud particles in aluminium matrix was achieved. Pin on disc equipment is used to find out the amount of wear loss occurred for the tested samples. Different values for different samples are carefully recorded and plotted a graph which clearly depicts the effect of red mud on aluminium soft matrix. It was clearly found that increase in amount of red mud particles which affect greatly on the base matrix accompanying the higher resistance to surface wear against rubbing action carried with specific load. Increase of red mud composition in aluminium matrix from 2% to 8% will results in decrease in wear rate of about 72% compare to the rest of the composition there by indicating that the increase in the addition of red mud will provide better wear resistance. This is because the intentional impurities added leads to the distortion of the lattice structure by added grains distributed within the regular arrangement of parent atoms thereby exhibits greater susceptibility to resist wear loss under different loading conditions.

## REFERENCES

- [1] Karl Ulrich Kainer., "Basic of Metal Matrix Composites", Copyright © 2006 Wiley-VCH Verlag GmbH & Co.
- [2] Mr.Saravanan, C., Mr. Subramanian, K., Mr.Ananda K., V. And Mr.Sankara N., R. "Effect Of Particulate Reinforced Aluminium Metal Matrix Composite –A Review", *Mechanics And Mechanical Engineering*, Vol. 19, No. 1 (2015), pp 23
- [3] Mr.Shaikshavali G., Dr.VenugopalGoud E., Mr.Murali Mohan M. "Mechanical Properties Of Al6061 Based Metal Matrix Composites Reinforced With Ceramic Particulates And Effect Of Age Hardening On Its Tensile Characteristics" *International Journal Of Engineering Research And General Science* Volume 4, Issue 2, (March- April, 2016)
- [4] Mr. Jay P. Shirsat, Mr. A. K. Virkunwar., "Study Of Metal Matrix Composites of Automobile Brakes", *International Journal On Recent And Innovation Trends in Computing And Communication*, Volume: 4 Issue: 4., pp 100-104
- [5] Dr.P.V.Krupakara, H.R.Ravikumar, "Corrosion Characterization Of Aluminium 6061 / Red Mud Metal Matrix Composites In Sea Water" *International Journal Of Advanced Research In Chemical Science (IJARCS)*, Volume 2, Issue 6, June 2015, PP 52-55
- [6] Jithin Jose, P. Muthu., "Studies On Mechanical And Tribological Properties Of Aluminum Based Metal Matrix Composites – A Review", *International Journal Of Advance Engineering And Research Development*, Volume 2, Issue 11, Nov-2015
- [7] Lokesh K. S., Bandu Ummaji, Gururaj P., K. Rayappa, Yashavantha J., Effect of Red Mud Particles on Scratch Resistance of Aluminum Based Metal Matrix Composites, *American Journal of Aerospace Engineering*, Vol. 5, No. 1, 2018, pp. 24-29. doi: 10.11648/j.ajae.20180501.14
- [8] P.V.Krupakara., "Corrosion Characterizationm of Al6061/Red Mud Metal Matrix Composites" *Portugaliae Electrochimica Acta* 2013, 31(3), 157-164.
- [9] Neelima Devi Chinta, N. Selvaraj, V. Mahesh., "Characterization Of Aluminium-Red Mud Tungsten Carbide Hybrid Metal Matrix Composite", *International Conference On Electrical, Electronics, And Optimization Techniques (ICEEOT) -2016*
- [10] KS nbspLokesh, KS Lokesh Critical Review On Automobile Applications Of Hybrid Fibre Reinforced Plastics - *International Journal of Creative Research Thoughts (IJCRT)* 6 (1), 302-307
- [11] KS Lokesh, T Pinto, M Gowspeer ,Effect of E-waste Rubber on Wear Behaviour of Glass fibre Reinforced with Epoxy Composites - *IJASRE*, 2018
- [12] K.S. Lokesh, Thomas Pinto, C.G. Ramachandra. Effect of Tool Wear & Machinability Studies on Polymer Composites; a Review. *International Journal of Engineering and Information Systems*, 2017, 1 (5), pp.71-77. <<http://www.ijeais.org/index.php/vol-1-issue-5-july-2017/>> . <hal-01571294>
- [13] KS Lokesh, BY Karthik, CG Avinash Experimental Study on Tribological Characteristics of E-waste filled Fibre Reinforced Plastics, *International Journal of Scientific Research in Mechanical and Materials – 2018*
- [14] Lokesh K.S, Dr.Thomas Pinto, & Ravi S.M. (2017). Evaluation of Mechanical Properties and Wear Characterization of Polymer Composites under Varying Temperature Conditions: A Review. *International Journal of Engineering and Information Systems (IJEAIS)*,1(4),64–68. <http://doi.org/10.5281/zenodo.821168>