

# Cryogenic Treatment Effect on NiTi Wire Under Thermomechanical Cycling

Letícia Contaifer de Moraes<sup>1</sup>, Tadeu Castro da Silva<sup>2</sup>, Arthur Pinheiro Barcelos<sup>3</sup>, Edson Paulo da Silva<sup>4</sup>

<sup>1,2,3,4</sup> Dept. of Mechanical Engineering, University of Brasilia (UnB), DF, Brazil

\*\*\*

**Abstract** - Shape Memory Alloys (SMA) have been explored for their capacity of recovering great strains through heating in several engineering applications since the discovery of the shape memory effect on NiTi. This material was thoroughly used in actuators and several papers were dedicated to understand the shape memory effect behavior under thermomechanical cycling to improve SMA actuator performance. This work investigated the effect of cryogenic treatment in Ni<sub>54</sub>Ti wires under constant stress and thermal cycling. An analysis was done by comparing the number of cycles until failure and strain behavior of treated and as-received samples. Results showed a decrease in the plastic strain, but also a loss of recoverable strain after the treatment and about the same fatigue life when compared to as-received wires.

**Key Words:** Shape memory alloys, fatigue, cryogenic treatment, NiTi, Smart actuators

## 1. INTRODUCTION

Since the Shape Memory Effect (SME) was first observed, engineers rushed to put materials capable of showing this effect into use in commercial applications. For Shape Memory Alloys (SMA), NiTi was the first material to show real commercial viability and it became a staple for SMA in the engineering world due to the SME, biocompatibility [1,2] and the fact it can be easier to fabricate than other SMA [2]. SMA with strain recoverable by both temperature and stress found use in several engineering applications on different industry sectors such as robotics, automotive, medical and aerospace [2]. One of the applications that highlight the thermally activated SME is the SMA actuator. Those devices became commercially successful due to the great recoverable strain of SMA that surpass conventional metals and the possibility of acting under stress and reacting to environment changes [2].

Considering SMA actuators are subject to continuous cycles of deformation and recovery, fatigue is expected as it would with any other engineering material [3]. It was observed that the cycling not only causes structural damage, but it can also modify the SME itself. Changes in transformation temperatures and loss of recoverable strain have been notified as effects of the thermomechanical cycling [4]. Since functional properties

are modified, this phenomenon was coined as functional fatigue [3] or thermomechanical fatigue [4].

In order to further investigate the fatigue in SMA, this work explored heat treatment. Specifically, the effects of cryogenic treatment on NiTi wires under thermomechanical cycling were analyzed. This type of treatment found great success on raising hardness and durability of machinery tools and it has been used in gears, bearings, medical devices and others [5]. However, cryogenic treatment in SMA is still a new field of study. Vinothkumar et al. [6] and Singh et al. [7] tried and documented results of the performance of cryogenic treated NiTi drills for endodontic applications, reporting back improvement on durability and cutting. This work aimed to contribute to the cryogenic treatment research with a focus on the material behavior under thermomechanical cycling. The analysis was done by comparing the number of cycles until failure and evolution of the strain of as-received and cryogenic treated NiTi wires. The experimental setup was developed to simulate similar conditions of a regular SMA actuator.

## 2. MATERIALS AND METHODS

### 2.1 Materials

SMARTFLEX® NiTi wires with 54% of Ni content and 0.15 mm diameter were investigated. Transformation temperatures are reported on Table 1 for both cryogenic treated and as-received wires. Those temperatures were obtained by DSC (Perkin Elmer® 8000 device). According to Table 1, the material is completely martensitic at room temperature.

**Table -1:** Transformation temperatures in °C

	$M_f$	$M_s$	$A_s$	$A_f$
As-received	32.91	40.55	83.69	88.35
Cryogenic treated	32.34	40.74	83.52	87.61

## 2.2 Cryogenic Treatment

Wire samples of 100 mm of length were completely immersed in liquid nitrogen (-196 °C) for 12 hours. Afterwards, they were removed from the tank and left to heat back naturally to room temperature. The cooling rate was estimated using the time to necessary to immerse the sample as being -44.4 °C/min.

## 2.3 Experimental Procedure

Six samples of about 100 mm wire length were subjected to thermal cycling under constant stress of 151 MPa. Three of those were used as-received and the other three were cryogenic treated and then used in the experiment. Fig 1 shows the experimental apparatus with its key elements numbered from 1 to 6 and Fig 2 is a schematic of the apparatus.



Fig -1: Experimental apparatus

1. 5 kg GL load cell
2. Variable speed fan
3. NiTi wire sample
4. Micro-Epsilon CT-SF22 temperature sensor
5. Load
6. Ima30-40NEIZC0K inductive sensor.

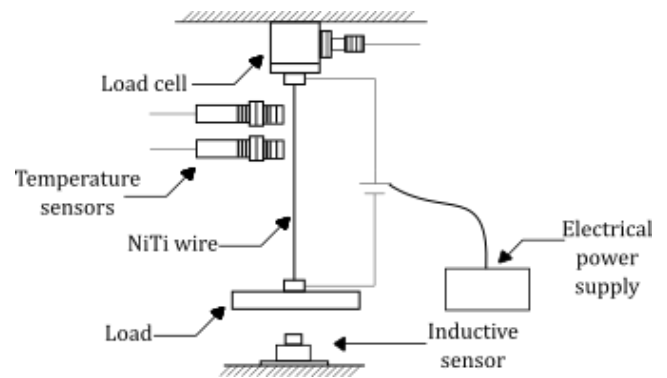

Fig -2: Schematic of the experimental apparatus

The heating was done through Joule effect by an electric source of 6.5 V that supplied a current of about 0.75 A to the wire. A fan was used for cooling and the room was kept at about 18 °C through the whole experiment. The experimental procedure was done as follows [4]:

1. Crimp both ends of the wire to obtain a net length of about 90 mm;
2. Position the wire on the experimental setup and then attach a device capable of holding the load on the free end of the wire;
3. Insert appropriate weights to obtain the stress level chosen for the experiment;
4. Heat the wire for 8 seconds by supplying enough electric current to induce complete martensitic transformation in order to obtain 100% austenite;
5. Cut off the electric current and air cool the wire for 8 seconds;
6. Repeat steps 4 and 5 until the fracture of the wire.

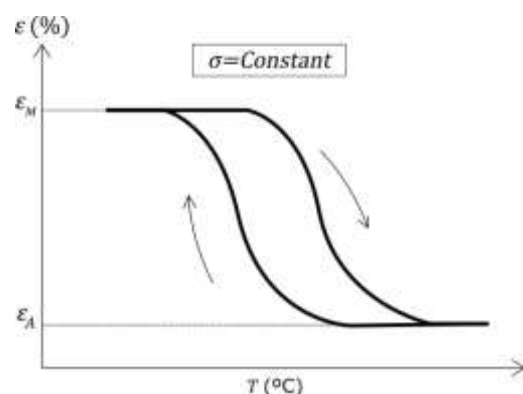

Fig -3: Thermal cycling of SMA under constant loading

The experimental data obtained during the procedure such as fatigue life and engineering strain were analyzed. Strain data was separated in martensitic strain  $\epsilon_M$  and

austenitic strain  $\epsilon_A$ . They were defined as the strain in martensitic and austenitic states respectively (Fig 3). In order to analyze recoverable strain, the difference between  $\epsilon_M$  and  $\epsilon_A$  was taken as the Shape Memory Effect (SME) [4].

In order to measure plastic strain during the martensitic phase, the difference between  $\epsilon_M$  in the  $n$ th cycle and  $\epsilon_M$  in the second cycle was used and then called  $\delta$  [4]. Every strain measure taken was calculated relative to the net length free of any load and the smallest length of the loaded wire obtained in the austenitic phase.

### 3. RESULTS AND DISCUSSION

Main results concerning fatigue life are summarized on Table 2 where AR stands for as-received and CT stands for cryogenic treated samples. It was observed that for the applied conditions, the cryogenic treatment didn't cause major changes in the number of cycles until failure ( $N_f$ ). The standard variation of the whole population was of 348.45 cycles and variation coefficient was 24.06%.

**Table -2:** Summary of fatigue life results

151 MPa	
Wire sample	$N_f$
AR1	1397
AR2	1100
AR3	1143
CT1	1507
CT2	2158
CT3	1383

Strain results for every sample are on shown on Fig 4 to Fig 9.  $\epsilon_M$  and  $\epsilon_A$  increased as the cycling went on and SME stayed constant as reported by [4]. This behavior was similar for both AR and CT wires, but the strain was larger on the AR case. The maximum strain was observed in the cycle immediately before failure. It reached about 6.5% for CT wires and 12.5% for AR wires.

A larger variation of SME was observed for the CT wires. Also the mean SME was smaller compared to AR. Using the chosen points used for the plot, the mean SME for CT1, CT2 and CT3 were 3.10%, 3.13% and 3.72% respectively. For AR1, AR2 and AR3 they were 4.99%, 4.98% and 5.58% respectively. For all these values the standard deviation was 0.98% and variation coefficient was 22.9%. The mean SME for AR was 5.18% and 3.32% for CT which shows a decrease in recoverable strain.

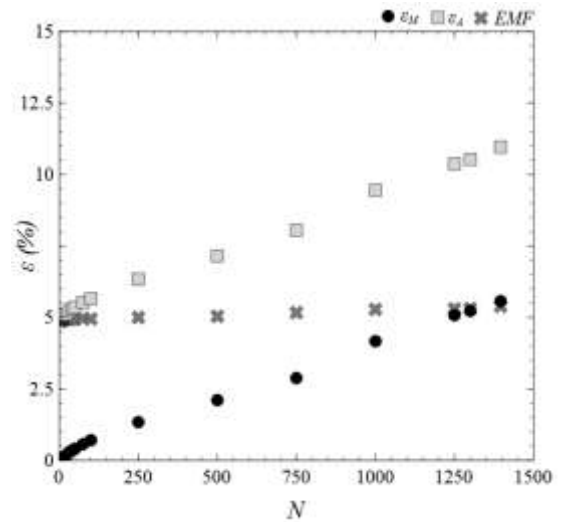

**Fig -4:** AR1 Strain evolution

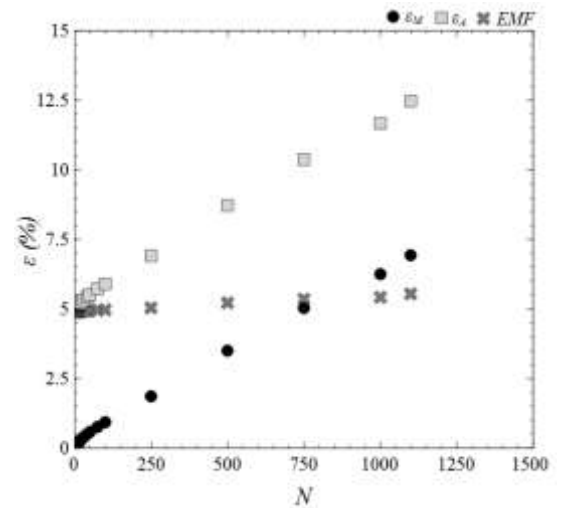

**Fig -5:** AR2 Strain evolution

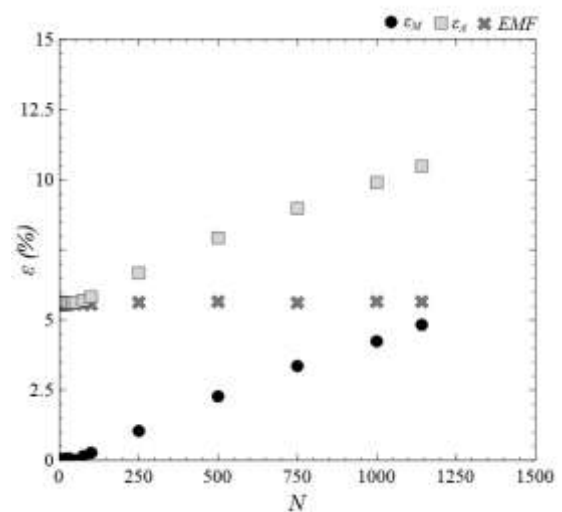

**Fig -6:** AR3 Strain evolution

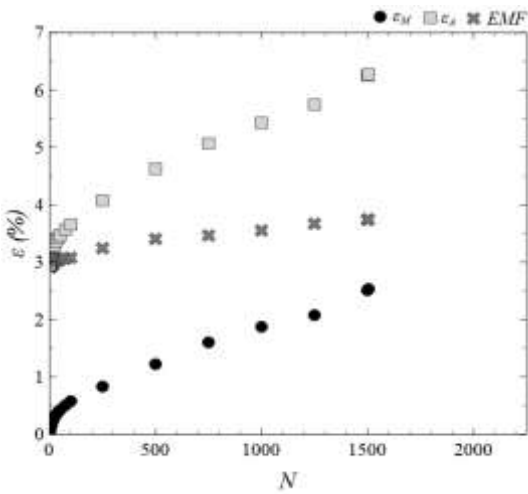

Fig -7: CT1 Strain evolution

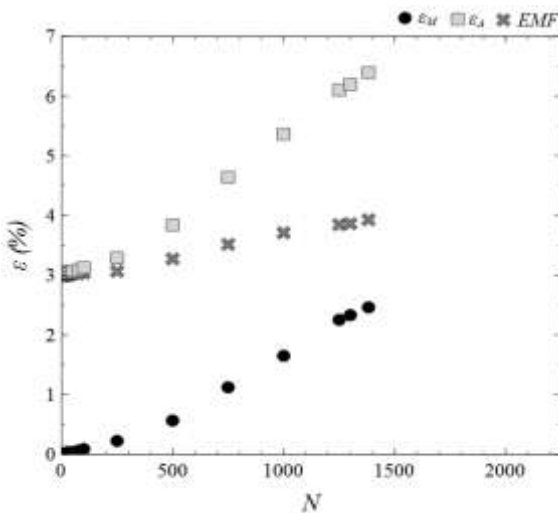

Fig -8: CT2 Strain evolution

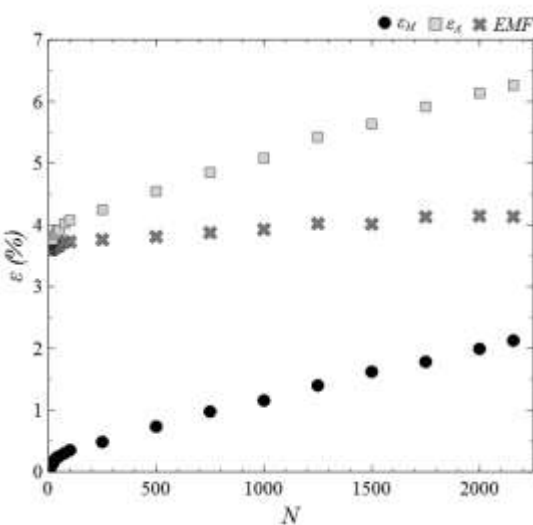

Fig -9: CT3 Strain evolution

The variation of both  $\epsilon_A$  and  $\epsilon_M$  is related to the accumulation of plastic deformation. This can be verified macroscopically as an increase in wire length in late cycles. Fig 10 and Fig 11 show the evolution of  $\delta$  for each sample. As expected, considering the analysis of data plotted in Fig 4 to Fig 9, the plastic deformation was larger on AR samples and reached almost 8% in AR2 (Fig 5). CT2 (Fig 8) showed the largest  $\delta$  for its group (3.38%). Also, a larger variation of  $\delta$  behavior can be observed for AR leading standard variation of the means to 0.24% compared to 0.09% for CT. Since the number of cycles until failure was similar, it's implied that the  $\delta$  rate in relation to  $N$  was smaller for CT wires. Comparing the mean values,  $\delta$  for CT was 36.0% smaller than for AR.

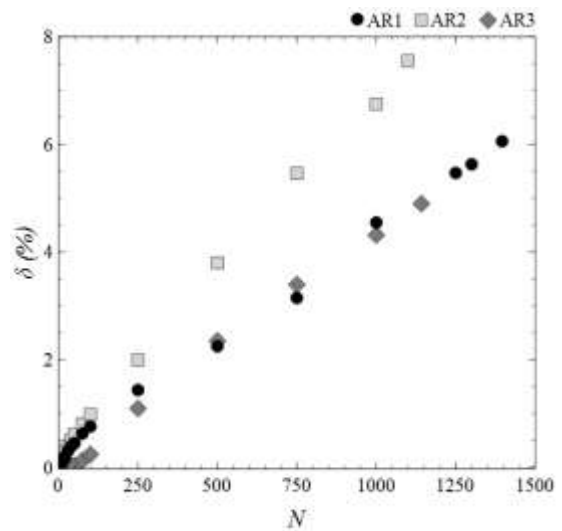

Fig -10: Plastic strain evolution of AR wires

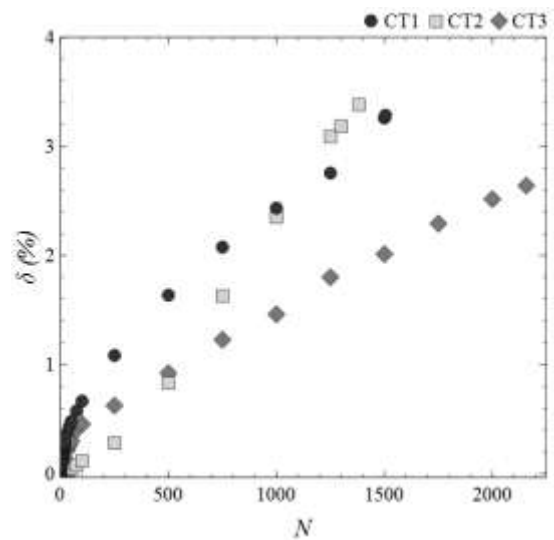

Fig -11: Plastic strain evolution of CT wires

It can be concluded that the strongest effect of the cryogenic treatment was the reduction of the plastic strain with a decrease in the *SME*.

#### 4. CONCLUSIONS

It was shown that in the chosen conditions for the experiments done in this work, cryogenic treatment affected NiTi wires under thermomechanical cycling. While the number of cycles until failure didn't change much and remained around 1500 cycles, the mean plastic strain was reduced in about 36.0%. The mean recoverable strain fell about 35.9% compared to as-received wires and varied with the cycling while in as-received samples the recoverable strain was almost constant.

#### ACKNOWLEDGEMENT

This work was supported by the FAPDF (Foundation for Research Support of the Federal District) and CAPES (National Council for the Improvement of Higher Education), linked to the Brazilian Ministry of Education, Brazil.

#### REFERENCES

- [1] Van der Wijst, M. W. (1992). *Shape Memory Alloys featuring Nitinol*.
- [2] Jani, J., Leary, M., Subic, A., & Gibson, M. (2014). A review of shape memory alloy research, applications and opportunities. *Materials & Design* (56), 1078-1113.
- [3] Eggeler, G., Hornbogen, E., Yawny, A., Heckmann, A., & Wagner, M. (2004). Structural and functional fatigue of NiTi shape memory alloys. *Materials Science and Engineering A* (378), pp. 24-33.
- [4] Mammano, G. S., & Dragoni, E. (2014). Functional fatigue of Ni-Ti shape memory wires under various loading conditions. *International Journal of Fatigue* (69), pp. 71-83.
- [5] Baldissera, P., & Delprete, C. (2008). Deep Cryogenic treatment: a bibliographic review. *The open mechanical engineering journal*, 2, pp. 1-11.
- [6] Vinothkumar, T., Miglani, R., & Lakshminarayanan, L. (2007). Influence of Deep Dry Cryogenic Treatment on Cutting Efficiency and Wear Resistance of Nickel-Titanium Rotary Endodontic Instruments. *JOE - Journal of Endodontics*, 33 (11), pp. 1355-1358.
- [7] Singh, A., Chandak, G. M., & Saxena, A. (2013). Effect of cryogenic treatment on nickel-titanium endodontic instruments. *International Journal of Dental Clinics*, 5 (1), pp. 4-7.