

Plant health monitoring and controlling of environment in a Conservatorium

Harshitha K¹, Jainita R S², Apoorva M Gowda³, Rekha P⁴

^{1,2,3}UG student, Department of ECE, BNM Institute of Technology, Bangalore, India

⁴Associate Professor, Department of ECE, BNM Institute of Technology, Bangalore, India

Abstract - India is an agricultural country and farmers are the backbone. However, often farmers commit suicide due to losses incurred as a result of low price for crops, loss of crops as a result of disease or natural calamities. In addition labor cost is also high. Crop losses due to pests and pathogens are around 20 and 40 % of the total production. Researchers have been striving to find solutions to some of these problems. Green house farming is one such method where plants are grown under controlled environment to maximize the yield. This paper presents image processing technique for disease detection and analysis; indicate percentage of disease; design and development of a low cost automated control system to provide optimum environment conditions for better growth and yield of the crop.

Key Words: Conservatorium, disease, sensor, control action, crop, yield

1. INTRODUCTION

Protection of plants in general and protection of crops against diseases in particular are important for better yield. Crop losses due to pathogens, pests, animals, and weeds are about 20 to 40% of global agricultural productivity [1]. These losses can be reduced by monitoring health of the plant using technology and rising alerts upon detection of disease or when the disease crosses certain threshold. Image capturing and processing is one such technique to detect the health of the plant.

All plants and vegetation require certain conditions for their healthy growth. It is necessary to control the environmental conditions to make them optimum for the best growth of plants. Parameters, such as humidity, temperature, light intensity, soil moisture etc. are monitored and controlled to create the optimal environment. An automated management reduces manual intervention, labor cost, implements necessary action with least time delay. An embedded system can be used to control devices, which in turn controls parameters of interest. A microcontroller receives data from sensors and generates an actuating signal to control the devices namely, bulb, fan, a motor for supplying the water etc. An Arm microcontroller such as LPC 2148 is used as a controller in the present work. Further, when the parameter crosses a prefixed reference, sensor data is transferred to registered mobile using Wi-Fi module. This keeps the farmer aware of environmental conditions in

the farm. Developed system is useful in conservatorium, a greenhouse attached to a dwelling for growing plants. The most important advantage of a conservatorium is a facility to grow fresh vegetables and fruits throughout the year irrespective of seasonal changes.

2. EXPERIMENTAL

Monitoring and control of parameters, such as health of the plant, ambient humidity, temperature, light intensity, soil moisture etc. is of concern in the present work. Fig.1 shows the block schematic of the experimental setup.

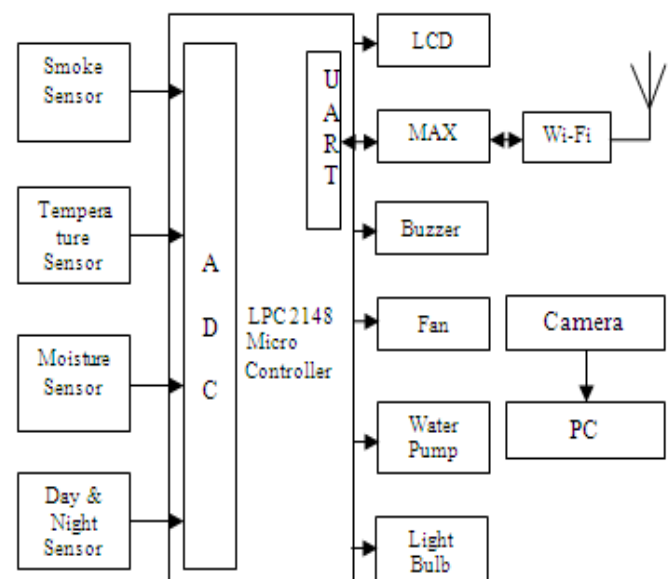

Fig 1: Block schematic of the experimental setup.

Need to effectively grow a plant is of increasing demand in agricultural industry for improving the yield. In order to do so, it is important to monitor the plant during its growth period, as well as, at the time of harvest. Plants can suffer from viral, fungal and bacterial diseases. Here, bacterial and fungal affected leaf diseases are considered for experimentation as viruses produce no telltale signs that can be readily observed and often easily confused with nutrient deficiencies and herbicide injury. One method to detect these bacterial and fungal diseases is manual inspection and detection with the help of botanic experts; but manual detection of leaf diseases is much laborious and time

consuming task. So, there is a need for machine based method to detect the plant diseases with better efficiency as compared to manual detection. Image Processing involves the steps of image acquisition, pre-processing (Image Contrast Enhancement), image segmentation, feature extraction, leaf disease detection & classification. In the present work, image acquisition is performed by considering RGB color disease affected leaf image. Image pre-processing is performed to enhance the image quality using histogram equalization. Image segmentation is performed using k-means clustering. Image feature extraction is performed to extract the features of leaf disease symptoms. Finally, disease analysis and classification is performed using modified SVM-CS (support vector machine) classifier. Fig 2 shows images of diseased leaves. Image of a leaf is input to the MATLAB program and the program indicates the percentage of disease in the image which is indicated in Fig 3.

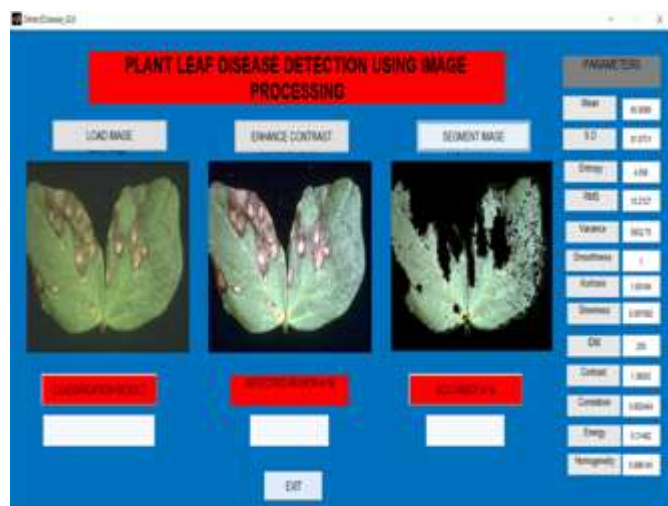

Fig 2: Diseased leaves

The LPC2148 is an ARM 7 based low power consumption, high-performance 32-bit RISC Microcontroller with two 10 bit ADCs and multiple serial interfaces and UART [2]. LPC 2148 works on just 3.3 V power supply. Two fast I2C-bus (Inter IC communication), SPI (Serial Peripheral Interface), SSP (Synchronous Serial Port) and two UARTs are the available serial interfaces. This microcontroller supports In System Programming (ISP) which is facilitated using serial port. A serial communication is manifested between the controller and Wi-Fi module using MAX232 interface. Each of the sensors provides an analog signal which is fed to ADC of LPC 2148 and processed for control operations. The internal peripheral ADC converts incoming analog data to digital. Fourteen analog inputs are provided with two 10-bit A/D converters with very low conversion times. Microcontroller is programmed to operate on this digital data and initiate the necessary action. Three separate relays are used to drive the fan, motor and the bulb. Two sensor signals are handled at any given time as two ADCs are

available on board. Time division multiplexing technique can be used to handle multiple signals. Based on ADC data, microcontroller takes decision for switching ON or OFF of the respective relay. An inverting current booster ULN2803 is used to supply sufficient drive for the relay operation.



Fig 3: Percentage of disease in the selected image (=39%)

The Smoke sensor (MQ2) is used to sense smoke or hazardous gases such as carbon monoxide, methane, propane, i-butane and carbon dioxide. Upon detection of any of the above mentioned gases, conductivity of the sensor increases, which is recorded by measuring the analog voltage. Change in measured voltage is a measure of concentration of the gas. If the measured value crosses the prefixed thresh-hold value then microcontroller activates a buzzer to alert the farmer.

LM35 temperature sensor is used to monitor the temperature of the conservatorium. This sensor measures temperature and produces output voltage which is linearly proportional to temperature in centigrade. Preferable temperature range for most of the plants is between 20°C to 35°C. For instance, optimum temperature for heightening of tomato plants is in the range of 18°C to 32°C. A program is developed to alert the farmer if the temperature is out of the required range. If the temperature exceeds 40°C, the controller switches the fan ON to drive out the heat from the conservatorium and keep it cool.

Moisture sensor senses the extent of wetness of soil. Resistance of the moisture sensor is proportional to water content in the soil. If the soil is dry, program in the microcontroller turn on a submersible motor to pump the water and supply it to the farm. Pumping of water is continued until the soil is sufficiently wet (microcontroller controlled).

Photosynthesis is an important process taking place in plants in the presence of sunlight. In an effort to promote photosynthesis during night times a light dependent resistor (LDR) is used. Resistance of the LDR is proportional to the ambient light. Lower the light intensity higher is the resistance and vice versa. When ambient light intensity is below the prefixed thresh-hold, microcontroller turns on the bulb. Red and Blue light emitting bulbs are preferred to aid the photosynthesis process. Activating photosynthesis

during night is beneficial to mankind as carbon dioxide is consumed and oxygen is produced in the process.

Present work aimed at conserving energy and bandwidth. Hence continuous transfer of data, out of conservatorium is not done. Corrective actions are automatic within the conservatorium using microcontroller. However, interfacing of Wi-Fi module (ESP8266) with microcontroller is tested for wireless data transfer using Telnet protocol.

3. RESULTS AND DISCUSSIONS

Developed system is tested at the University of Agricultural Sciences, Gandhi Krishi Vignan Kendra (GKVK), Department of Horticulture, Bangalore, Karnataka. The test set up was installed in a conservatorium with tomato plants. Fig 4 shows a glimpse of the Conservatorium at GKVK and Fig 5 shows cultivation of Tomato plants inside the conservatorium. Fig 9 shows a prototype model developed in the present work used in the lab environment mimicking the GKVK conservatorium and small plants being grown inside it.



Fig 4: Conservatorium in GKVK



Fig 5: Tomato plants in conservatorium

Fig 6 shows installation of the developed system close to the tomato plants grown inside conservatorium. The optimum temperature and moisture conditions are monitored and controlled using the designed prototype. Fig 6 shows use of system developed.



Fig 6: Installation of the developed system at GKVK



Fig 7: Functioning of the developed system

Description of the status of devices shown in Fig 7: Fan is on indicating temperature more than 40°C; motor which pumps water to the farm turns on indicating dry soil (motor is covered in Fig 7). As there is no detrimental gases detected and smoke sensor is in off condition. As there is sufficient light available already the bulb is not on.

Fig 8 shows working of Telnet protocol for wireless data transfer. It may be observed that conditions of the sensors are displayed on mobile phone. The conservatorium manager gets the information of the sensors through the TCP telnet terminal.



Fig 8: TCP Telnet Terminal Results



Fig 9: Prototype developed for testing in the lab environment.

Some of the researchers have used IoT (Internet of Things), wireless networks for continuous transfer of sensor data to a distant node [3-10]. But, this adds overheads in terms of power consumption and bandwidth consumption. Present work minimizes power consumption using automated wired control of devices and saves bandwidth by transferring the data only when the specified range is crossed.

4. CONCLUSIONS

Developed system is very useful to monitor health of plant, take corrective action when the parameters of interest cross the specified ranges required. Thus provide optimum environmental condition for better growth and yield of the crop. Integration of disease detection system and ambient control are unique feature of this work. ARM microcontroller can be explored to do the image processing part to eliminate the need for PC. Developed system can be installed with slight modifications anywhere to cultivate any type of crop. Automated controlling of devices eliminates the middleman and help farmers to produce high quality, high yield crops.

ACKNOWLEDGEMENT

Authors thank, department of ECE, BNMIT, Bangalore, and GKVK, Bangalore, for encouraging to take up this work, providing lab facilities and completing it. We express our wholehearted thanks to our parents for their support and guidance.

REFERENCES

1. Serge Savary & Andrea Ficke & Jean-Noël Aubertot & Clayton Hollier, "Crop losses due to diseases and their implications for global food production losses and food security", 1 June 2012, Springer Science, Business Media B.V. & International Society for Plant Pathology, Food Sec. DOI 10.1007/s12571-012-0200-5.
2. http://www.keil.com/dd/docs/datashts/philips/lpc214_1_42_44_46_48
3. Ravi Kishore Kodali, Vishal Jain, Sumit Karagwal "IoT based smart greenhouse" Humanitarian Technology Conference (R10-HTC), 2016 IEEE Region 10. Date of Conference: 21-23 Dec. 2016.
4. Z. Xiaoyan, Z. Xiangyang, D. Chen, C. Zhaohui, S. Shangming, Z. Zhaohui, "The design and implementation of the greenhouse monitoring system based on gsm and RF technologies" Computational Problem-solving (ICCP) 2013 International Conference on, pp. 32-35, Oct 2013.
5. A.Bseiso, B. Abele, S. Ferguson, P. Lusch, K. Mehta "A decision support tool for greenhouse farmers in low-resource settings" Global Humanitarian Technology Conference (GHTC) 2015 IEEE, pp. 292-297, Oct 2015.
6. Marwa Mekki, Osman Abdallah, Magdi B. M. Amin". Greenhouse monitoring and control system based on wireless Sensor Network" Published in Computing, Networking, Electronics and Embedded Systems Engineering (ICCNEEE), 2015 International Conference on Sept. 2015.

7. Image processing for smart farming: Detection of disease and fruit grading M. Jhuria, A. Kumar, R. Borse” Image processing for smart farming: Detection of disease and fruit grading”Image Information Processing (ICIIP), 2013 IEEE Second International Conference on Dec. 2013.
8. Na Pang “ZigBee mesh network for greenhouse monitoring” Published in Mechatronic Science, Electric Engineering and Computer (MEC), 2011 International Conference on Aug 2011.
9. Ning Wang, Naiqian Zhang and Maohua Wang, “Wireless sensors in agriculture and food industry—Recent development and future perspective”, Elsevier Journal of Computers and Electronics in Agriculture, 2006, Vol 50, Page 1-14.
10. Jin-Shyan Lee, Yu-Wei Su, and Chung-Chou Shen, “A Comparative Study of Wireless Bluetooth, ZigBee, and Wi-Fi ”, Proceedings of The 33rd Annual Conference of IEEE Industrial Electronics Society (IECON), 2007, Taipei, Taiwan, page 1-5.

BIOGRAPHIES



Harshitha K has completed BE from department of ECE, BNMIT. She is interested in developing sensors useful in agriculture field.



Jainita R S has completed BE from department of ECE, BNMIT. She is interested in pursuing higher studies in Spintronics.



Apoorva M Gowda has completed BE from department of ECE, BNMIT. She is interested to the core domain of electronics.



Rekha P is working as Associate Professor in the department of ECE, BNMIT. She is interested in design and development of sensors.