

# A Hybrid Multilevel Inverter for Photovoltaic Applications

Niraj Dewangan<sup>1</sup> and Krishna Kumar Gupta<sup>2</sup>

<sup>1,2</sup>Department of Electrical Engineering, SISTec, Bhopal (M.P.) India

\*\*\*

**Abstract** – With the advent of improved DC to DC and multilevel power electronic converters, the performance of standalone and grid connected photovoltaic systems has been improved up to a large extent. Due to the increased popularity of PV applications, the conditioning units to interface the power electric devices have gained significant recognition over the past few years. In this regard, this paper describes the detailed analysis of five level reduced device count multilevel inverter with boost converter using maximum power point tracking algorithm. Maximum power point tracking technique in the photovoltaic systems is implemented using perturb and observe (P&O) to obtain optimal output of PV array by continuously tracking along the maximum power point (MPP). The simulation study has been carried out under MATLAB/Simulation environment.

**Keywords** – Multilevel Converters, MPPT, P&O technique, PV system

## I. Introduction

The photons carrying the energy of sunlight incident on photovoltaic array is converted into electrical energy. The output power of PV array is capable enough to feed the light loads such as lighting systems and DC motors. However, sensitive and sophisticated applications demand for power electronic converters to process the power output of array. The converters regulate the voltage and current at the load terminal and hence operate the array at maximum power in the grid connected systems [2-3]. The converters equipped with maximum power point tracking (MPPT) technique is based on an algorithm which keeps on detecting the maximum instantaneous power of the PV array. Since the operating point of the array vary intermittently, so the MPPT algorithm is required to set the operating point so as to extract and deliver maximum instantaneous power to the ac load through multilevel inverters [8]. The key advantage lying with the multilevel inverter is the ease of interface with any of the renewable sources such as photovoltaic, wind and fuel cells at the dc input.

Multilevel inverters employ a series of power semiconductor devices and capacitors with a single dc source or a multiple dc sources without a capacitor, which generate voltages with stepped waveforms in the output. With the rise in level, the synthesized output waveform of MLIs consists of increased steps thereby producing a staircase wave which approach near to the desired waveform [3]. The considered topologies for this approach are the CHB and NPC MLIs which requires various independent dc sources and number of capacitors respectively. Generally, each phase of a cascaded multilevel inverter requires “n” dc sources for 2n+1 level. This paper is dedicated to implement PV fed CHB and NPC MLIs with MPPT algorithm using fixed frequency carrier based PWM which utilizes equal dc sources in each phase to generate a seven level equal step multilevel output [6-9] to extract maximum power from the PV array using P&O [10]. This structure is well-suited for high power applications which operate with less THD for increased modulation index.

During constant solar irradiation, PV panels possess a unique operating point where power output of PV is maximized. The nonlinear characteristics of PV power considering a single PV cell is shown in Fig.1. The variation in solar irradiation and temperature under load variation makes the task of extraction of maximum power quite challenging.

**System Composition:** The system described in this paper has been categorized into three individual systems: - Generating a dc signal using photovoltaic system, Tracking maximum power from PV using MPPT, Step up of generated DC signal using boost converter, Pulse pattern generation and Conversion of DC signal to AC signal using single phase CHB and NPC-MLIs.

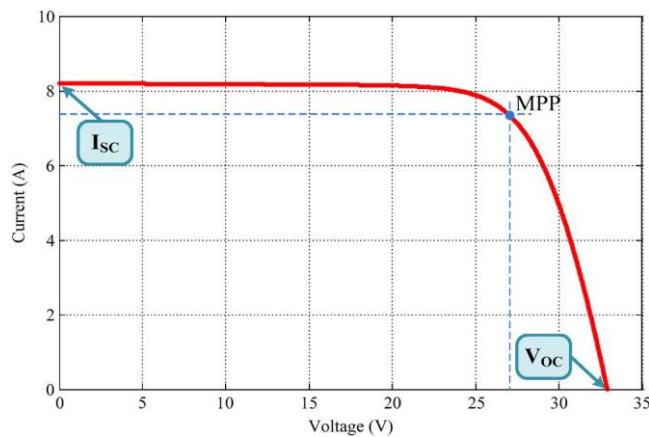

Fig.1 PV current-versus-voltage characteristics

## II. PV MODELLING

A solar cell can be modelled by connecting a current source in parallel with an inverted diode along with a series and a parallel resistance as shown in Fig.2. The series resistance represents the opposition offered in the path of flow of electrons from n to p junction and parallel resistance considers the effect of the leakage current. The output characteristic of a PV module depends on the solar insolation, the cell temperature and the output voltage of the PV module. It is required to model the PV module considering its nonlinear characteristics to implement the design and simulation of Maximum Power Point Tracking (MPPT) for PV system applications. The equivalent circuit of single diode model is depicted in Fig.2. The current source  $I_{ph}$  represents the cell photocurrent and  $I_D$  is the diode current with  $R_{sh}$  and  $R_s$  respectively denoting the shunt and series resistances of the cell.

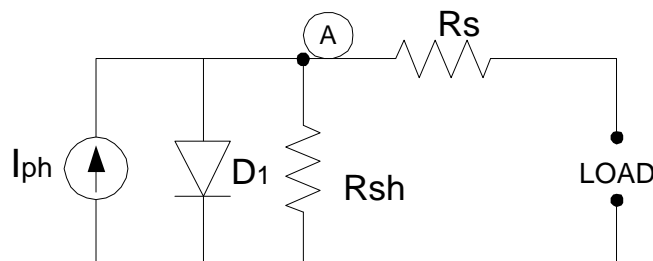

Fig.2 Equivalent model of the PV panel

The simulation model representing the PV array is based on the output current of a single PV equivalent model, and its mathematical equation is represented by

$$I = I_{ph} - I_r \cdot \left[ e^{\frac{q(V+I.R_s)}{n.k.T}} - 1 \right] - \frac{V+I.R_s}{R_p} \dots\dots\dots (1)$$

Where 'V' represents the output PV voltage of one PV panel,  $I_{ph}$  is the photocurrent,  $I_r$  is the saturation current,  $q$  is the electrical charge ( $1.6 \times 10^{-19}$  C),  $\eta$  is the p-n junction quality factor,  $k$  is the Boltzmann constant ( $1.38 \times 10^{-23}$  J/K), and 'T' is the temperature (in kelvins).

In Figs. 3 and 4, the power characteristics of the PV cell have been analysed, considering variation in solar irradiation and temperature change. The curve clearly depicts the nonlinear characteristics, and strong effect of intermittent behaviour of climate and weather conditions.

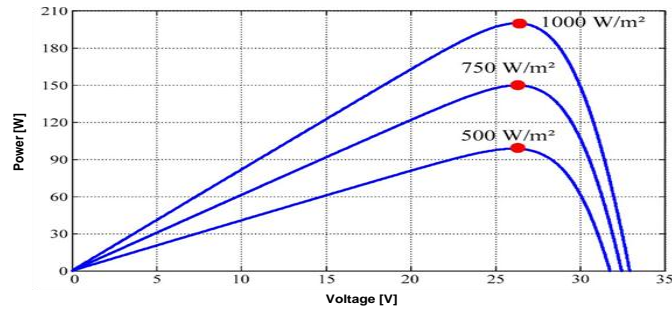

(a)

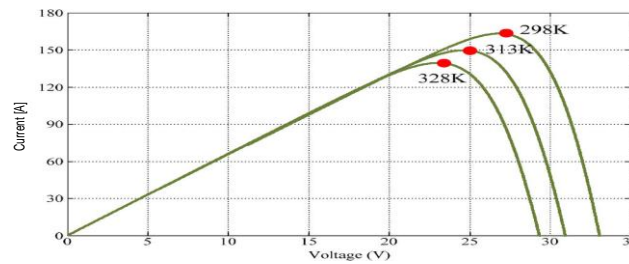

(b)

Fig.3 PV power characteristic for (a) different irradiation levels & (b) different temperature levels

With the wide variation in solar irradiation throughout the day, the generated output of PV module varies accordingly with rapidly varying weather conditions. To get rid of this problem, Maximum Power Point Tracking (MPPT) algorithm is used which keep on tracking the operating point of I-V curve to achieve to its maximum value. Therefore the MPPT algorithm ensures the maximum power delivery from the solar modules at any particular weather condition. In the proposed study, Perturb & Observe (P & O) algorithm is used to extract maximum power from the PV modules. The operation of P&O method is governed by periodically incrementing or decrementing the output terminal voltage of the PV cell and comparing the power obtained in the current cycle with the power of the previous one (performs  $dP/dV$ ). If the voltage varies and the power increases, the control system changes the operating point in that direction; otherwise, it changes the operating point in the opposite direction. Once the direction for the change of voltage is known, the voltage variation takes place at a constant rate. The flowchart for MPPT is shown in Fig.4 and the MATLAB/SIMULINK model for P&O algorithm is shown in Fig.5.

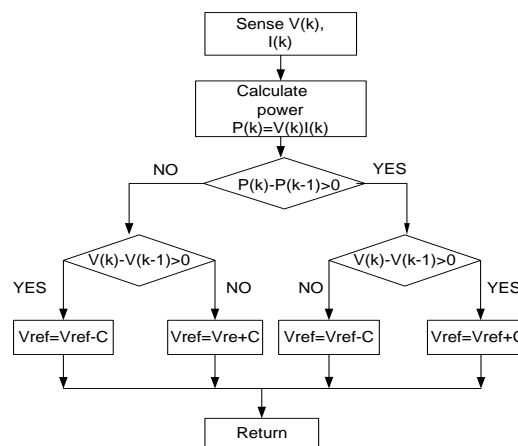

Fig.4 MPPT control flow chart

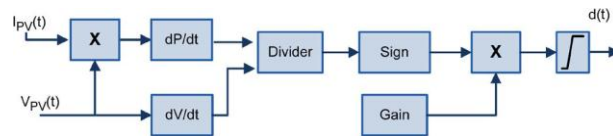

Fig.5 Implementation of P&O method through MATLAB/Simulink.

### III. Boost Converter And Rdc- Mli

In PV fed boost converter, the output voltage is greater than input voltage. In the model under study, a power IGBT is considered in boost converter as shown in Fig.6 .The output of the boost converter is shown in fig.7.

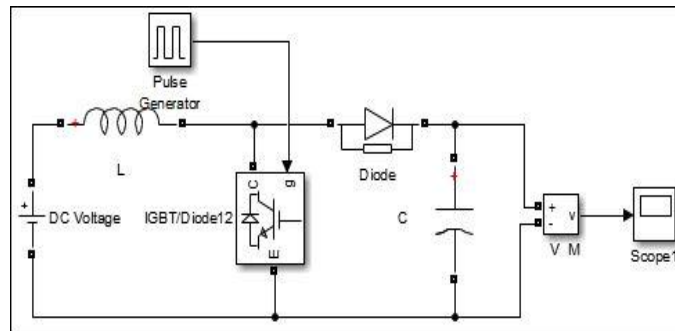

Fig.6 MATLAB/SIMULINK model for boost converter

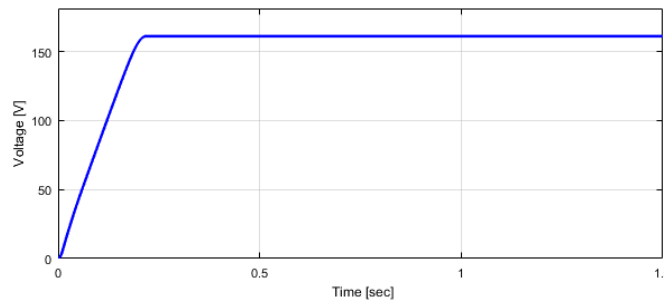

Fig.7 Output voltage of boost converter

The proposed topology is described with the help of a single-phase inverter with two input dc sources E1 and E2, as shown in Fig. 8. It has three pairs of active switches such as (T<sub>1</sub>, T<sub>1</sub>'), (T<sub>2</sub>, T<sub>2</sub>'), (T<sub>3</sub>, T<sub>3</sub>'). Since the elements of these pairs are complementary, there are eight valid operating modes. In symmetrical topology, the magnitude of the input to the proposed structure is the same, whereas in an asymmetrical configuration the magnitude of the input differs.

The number of output phase voltage level 'n' in the proposed multilevel inverter is given by equation (2).

$$n=2S+1 \dots\dots\dots(2)$$

Where, S is the number of dc sources.

The maximum voltage obtained for such a power circuit is given by

$$V_{max} = nV_{dc} \dots\dots\dots(3)$$

A PV fed five-level multilevel inverter with a standalone ac-load is shown in Fig.8. It is possible to obtain voltage levels +2V<sub>dc</sub>, +V<sub>dc</sub>, 0, -V<sub>dc</sub>, -2V<sub>dc</sub> by properly firing the switches of the proposed power structure.

The firing pulses are generated using multicarrier pulse width modulation technique. In this technique, as shown in Fig.9, a standard sinusoidal wave is compared with four number of triangular wave to generate the firing pulses for each switch in the multilevel inverter.

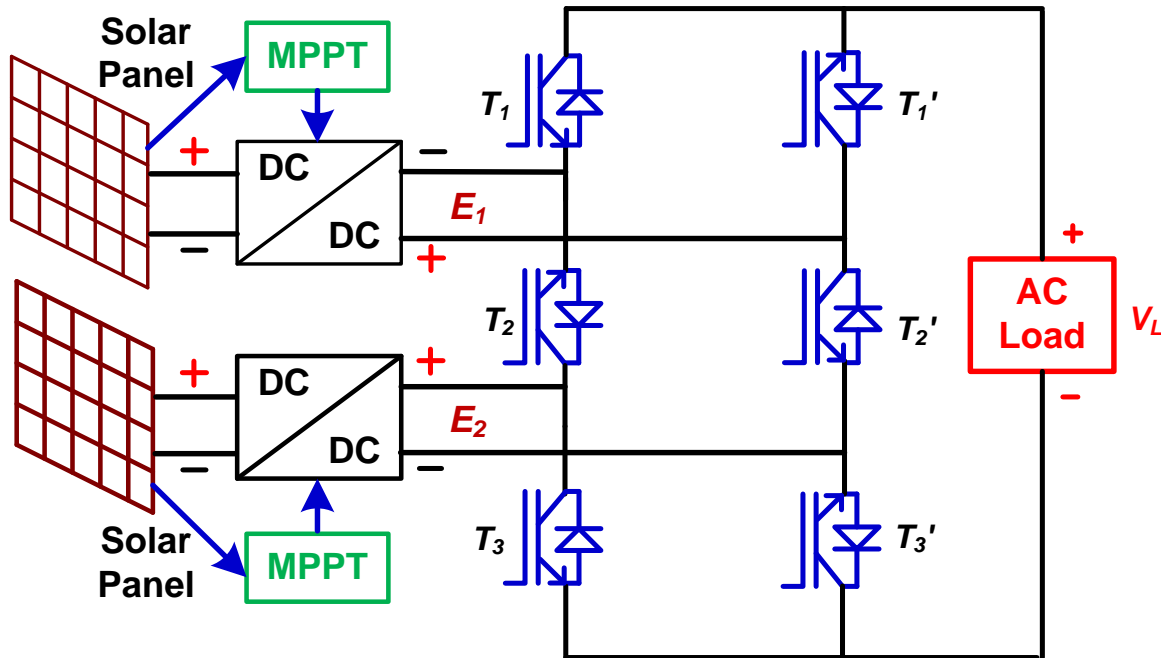

Fig.8 PV fed Five-level RDC multilevel inverter

Table I

Valid switching states for the proposed Configuration

STATE	Output Voltage [ $E_1 = E_2 = V_{dc}$ ]	ON state switches
1	$2V_{dc}$	$T_1', T_2, T_3'$
2	$V_{dc}$	$T_1', T_2, T_3$ $T_1, T_2, T_3'$
3	0	$T_1, T_2, T_3$ $T_1', T_2', T_3'$
4	$-V_{dc}$	$T_1, T_2', T_3'$ $T_1', T_2', T_3$
6	$-2V_{dc}$	$T_1, T_2', T_3$

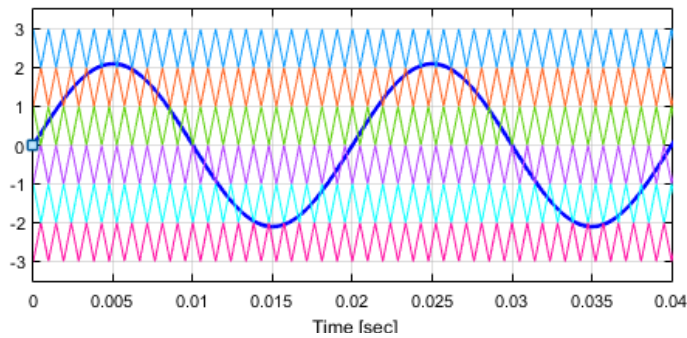

Fig.9 Multicarrier PWM technique for five-level multilevel inverter

#### IV. Simulation Study And Result Discussion

The simulation and performance analysis of the standalone PV system with the five-level RDC-MLI is simulated using MATLAB/Simulink software package. The PV fed multilevel inverter feeding an RL load ( $R = 50\Omega$ ,  $L = 11\text{mH}$ ) has been considered. Fig.10, fig.12 (a) & (b) show block diagram of PV fed MLI using MPPT and output waveform of the single phase PV based five-level reduced device count multilevel inverter.

Alternative phase opposition disposition triangular signals with frequency 1 kHz is employed as carriers and sinusoidal reference with frequency 50 Hz is used with an amplitude modulation index of 0.85. The so-called ‘universal control scheme’ as proposed in [6] is used to modulate the topology.

For a 5-level inverter, carrier and reference signals with aggregated signal are depicted in Fig.11

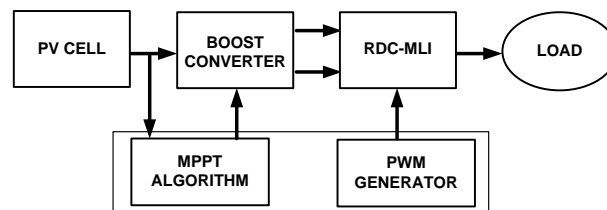

Fig.10 Block diagram of PV fed MLI using MPPT

The load current waveforms are sinusoidal and inductive in nature as required. The FFT spectrum of the load voltage and current determined using the FFT analysis tool are shown in Fig.12 (c) and fig.13 (c) respectively and the THD of voltage and current are 35.86%, 18.45% respectively.

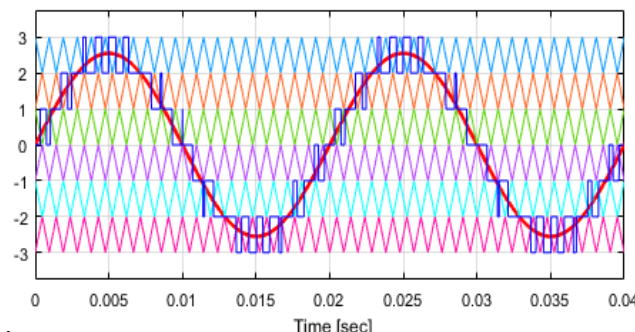

Fig.11 Reference and Carrier Waveforms with resulted Aggregated signal “a (t)”

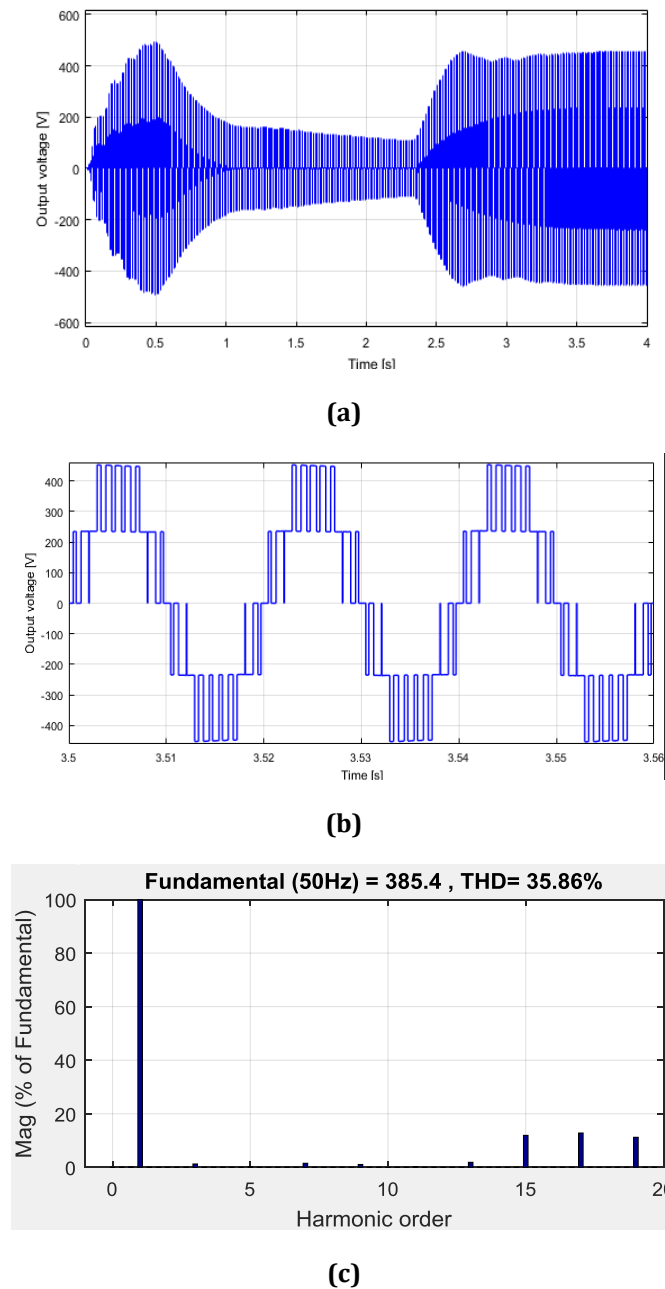
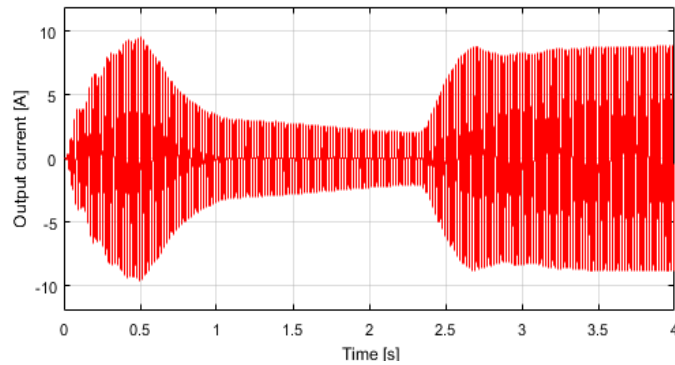
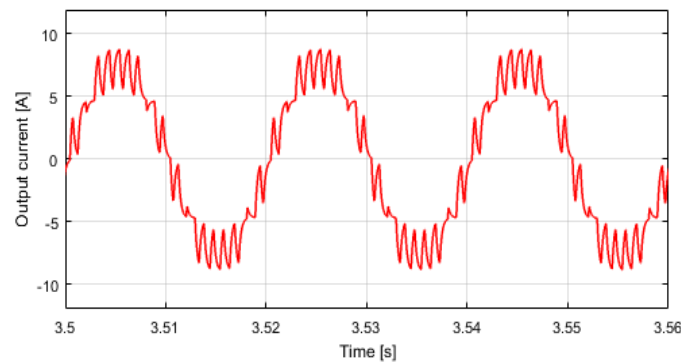

Fig.12 Simulated waveforms for five-level RDC-MLI; (a) & (b) load voltage  $V_L(t)$  ; and  
 (c) Harmonic profile of load voltage



(a)



(b)

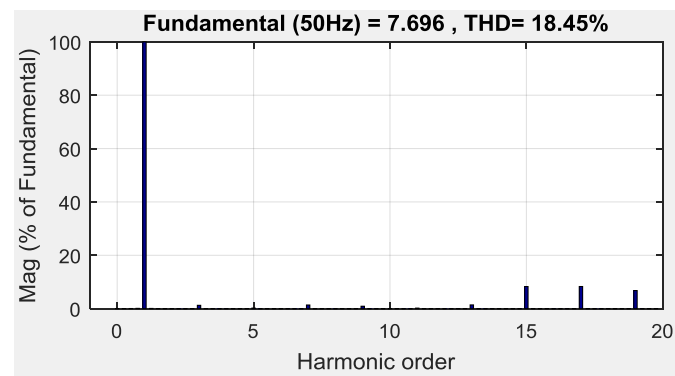

(c)

Fig.13 (a) & (b) Load current waveform of 7-level CHB MLI with RL load ( $R=100\Omega$ ,  $L=15\text{ mH}$ )

(c) Harmonic spectrum of load current

The proposed reduced device count multilevel converter is compared with basic commercial multilevel Inverters (NPC, FC, CHB) and some recently introduced converters. This comparison is done from different points of view as the number power switches, diodes and dc voltage Sources and reliability of the converter during switch/source failure. The comparison is given in Table III.



Table III

Comparative Analysis of the Presented Configuration with Other Structures

NUMBER OF DEVICES FOR THE SINGLE PHASE FIVE LEVEL INVERTER							
Type of Devices	Number of devices required						
	NPC	FC	CHB	Ref [14]	Ref [13]	Ref [9]	Proposed Topology
Main switches	8	8	8	22	7	8	6
Main diodes	8	8	8	22	10	8	6
Clamping diodes	12	0	0	0	2	0	0
DC bus capacitors/Isolated supplies/Solar Panel	4	4	2	1	2	2	2
Flying Capacitors	0	6	0	7	0	0	0
Reliability during switch failure	No	No	Yes	Yes	Yes	Yes	Yes
Reliability during source failure	No	No	Yes	No	Yes	Yes	Yes

## V. Conclusion

The simulation of PV fed five-level RDC-MLI with intermediate boost converter using MPPT technique has been described in this paper. The PV array output power delivered to the load can be maximized using P&O control algorithm. The boost converter is allowed to work in continuous mode and the switching sequence of multilevel inverter is generated by a PWM generator which uses APOD-PWM control scheme. Total Harmonic Distortion analysis was performed for proposed inverter output voltage with open loop configuration. By FFT analysis to examine the performance, it is clearly observed the harmonic profile is as expected, making it quite suitable for photovoltaic applications. The overall comparison shows that the proposed structure requires lower number of component for its operation.

## References

- [1] Venkatachalam, Jovitha Jerome and J. Karpagam, "An experimental investigation on a multilevel inverter for solar energy applications," *International Journal of Electrical Power and Energy Systems*, pp.157-167, 2013.
- [2] Ebrahim Babaei, Mohammad Farhadi and Farshid Najaty, "Symmetric and asymmetric multilevel inverter topologies with reduced switching devices," *Electric Power Systems Research*, pp. 122- 130, 2012.
- [3] Rodriguez, J.; Jih-Sheng Lai; Fang Zheng Peng; "Multilevel inverters: a survey of topologies, controls, and applications," *Industrial Electronics, IEEE Transactions on*, vol.49, no.4, pp. 724- 738, Aug 2010.
- [4] Gupta, K.K.; Jain, S., "A Novel Multilevel Inverter Based on Switched DC Sources," *Industrial Electronics, IEEE Transactions on*, vol.61, no.7, pp.3269-3278, July 2014.
- [5] Jia-Min Shen, Hurng-Liahng Jinn-Chang Wu and Kuen-Der, "Five-Level Inverter for Renewable Power Generation System, *IEEE transactions on energy conversion*," pp.257-266, 2015.

- [6] H. Nademi, A. Das, R. Burgos and L. E. Norum, "A New Circuit Performance of Modular Multilevel Inverter Suitable for Photovoltaic Conversion Plants," in *IEEE Journal of Emerging and Selected Topics in Power Electronics*, vol. 4, no. 2, pp. 393-404, June 2016..
- [7] Savita Nema, R.K. Nema and Gayatri Agnihotri, "Matlab/Simulink based study of photovoltaic cells I modules I array and their experimental verification," *International Journal of Energy and Environment*, pp.487-500, 2014.
- [8] K. K. Gupta, A. Ranjan, P. Bhatnagar, L. K. Sahu and S. Jain, "Multilevel Inverter Topologies With Reduced Device Count: A Review," in *IEEE Transactions on Power Electronics*, vol. 31, no. 1, pp. 135-151, Jan. 2016.
- [9] N. Prabakaran, K. Palanisamy, Analysis and integration of multilevel inverter configuration with boost converters in a photovoltaic system, In *Energy Conversion and Management*, Volume 128, Pages 327-342, ISSN 0196-8904, 2016.
- [10] Javier Chavarria, Domingo Bie!, Francesc Guinjoan, Carlos Meza and Juan J. Negroni, "Energy-Balance Control of PV Cascaded Multilevel Grid-Connected Inverters Under Level Shifted and Phase-Shifted PWMs," *IEEE transactions on industrial electronics*, pp.98-111, 2013.
- [11] Marcelo Gradella Villalva, Jonas Rafael Gazoli and Ernesto Ruppert Filho, "Comprehensive Approach to Modeling and Simulation of Photovoltaic Arrays," *IEEE Transactions on Power Electronics*, pp. 1198-1207, 2014.
- [12] J. Surya Kumari and Ch. Sai Babu, "Comparison of Maximum Power Point Tracking Algorithms for Photovoltaic System," *International Journal of Advances in Engineering & Technology*, pp. 133-148, 2015.
- [13] A, M.R.; Sivakumar, K., "A Fault-Tolerant Single-Phase Five-Level Inverter for Grid-Independent PV Systems," in *Industrial Electronics*, *IEEE Transactions on*, vol.62, no.12, pp.7569-7577, Dec. 2015.
- [14] A. Chen, L. Hu, L. Chen, Y. Deng, and X. He, "A multilevel converter topology with fault-tolerant ability," *IEEE Trans. Power Electron.*, vol. 20, no. 2, pp. 405-415, Mar. 2016.