

Smart Pill Box Health Care System

Nidhi Solanki¹, DR. P. H. Zope²

^{1,2}Dept. of Electronics and Telecommunication, SSBT's COET, Jalgaon (Maharashtra)

Abstract: To take proper medicine at proper time is necessary to become a healthy but failure of that can create big trouble for a patient. This is specially for the elderly patient who had problem in keeping track of their medicine. So to overcome this we made this Smart Pill Box which keep tracks of the dosage and duration between each consumption. Untimed medicine administration can always show adverse effects on the health of the patients. Hence, this Smart Medicine Box will remind the patient to take right dosage of right medicine at the right time. The basic idea for this paper is integrating the principle of Alarm clock with Light based slot sensing on a normal pill box. To make it more state-of-the-art, it is inbuilt with a GSM module for alerting the patient and also the chemist at the needed instant. By using GSM, system also send SMS to the patient for the medicine reminder.

Keywords: Smart pill box, Old age patients, Permanent diseases, Setting up time table, Bright light, Notification sound, SMS alert, Sensing capability.

INTRODUCTION

With the tremendous growth in medical technology, there is cure for many dreadful diseases through the intake of several new medicines. The number of medicines to be taken by each person has increased. It has become hard for us to remind ourselves to take the medicines at particular time. This Smart Pill Box helps us in reminding us of the medicine that we should take at that particular time. In this Pill Box we use GSM technology by which this system easily send SMS to the patient mobile number for reminding him/her about medicine.

1.1 Objectives

- 1) To provide fast curing of patient health by using our advantageous system.
- 2) To help people to take their medicine on time.
- 3) To help patients to take the required medicine in the right proportion without failure.
- 4) To make daily medication simple and efficient.

1.2 Necessity

Most common reason for the failure of a method of cure is the failure of the patient to administer the dosage in the right proportion and at right time. The new awaited feature in these so-called intelligent pill boxes is the availability of the automated alert system. The pill box intelligent system provides alert SMS with an alarm system. The user can set alarm time for medicine and when current time matches or equals the alarm time then the buzzer will ring and SMS is sent to the user. From such advanced technology, it is a boon for old age patient or user to remember the timing for medicine.

1.3 What is Smart Pill Box ??

The word "Pill Box" means many different kinds of pill containers, in a single compartment to those with a built-in timer. It is an advantageous, secure and automated solution that organizes, reminds and dispenses medications so the patient can take medicine properly and on-time. SMART PILL BOX makes it easy for you to take medicine without any failure. We used a

pillbox system containing 3 separate small pillboxes. Each box has an led display placed on the box. For our pill system, the user can store up to three different types of pills, which can be stored in those three small separate boxes.

II. LITERATURE SURVEY

Taking Medicine at right time in proper amount will lead towards the faster recovery. In reality what happens is that, they get their prescribed medication but fail to follow their health care professional's instructions. Many people while taking prescribed medication do not follow their doctor's' instructions. Some common reasons for this are People may start feeling better and decide to not finish all of the medication. In some cases people think this medication is not working and they may not notice an improvement in their symptoms right away and may stop taking the medication. In some other cases people try to save money and they think that these medications are expensive, and people may skip doses or take less.

According to World Health Organization, over 80% of the people above the age of 60 years are prescribed medicines that are to be administered 2 - 4 times a day. With the increase in Cardiovascular diseases and Diabetes among the peer group regular medicine administration has become a necessity. But among this another 40-60% is having the issues related to forgetting the taking of medicines at right time.

We found several different pillbox products available in the market. The cheapest one was the traditional pillbox, which contained seven boxes for seven different days of a week. Such pillbox normally cost around 200 INR. However, user had to load the pills to the boxes every week. At the time of loading pills in the box, people many time mix their pills with other pills in the same box would increase the risk of making mistakes. Another type of pillbox in the market is also available, which had the sound reminder, and was able to remind the user to take medicine at user specified time but it only remind the user at once a day. The costs of this type of pillbox were so high about 1000 INR, Therefore, we think it was necessary to build a cheap and functional smart Medicine box that could bring more convenience for the user. We then defined the specifications of our device based on the user needs. From the literature cited, the research proposed an idea of Smart Medicine Box that will adapt the features of time tracking and alarm triggering Additionally, as compared to the existing system, It will remind the user to take medicine not for once per day but thrice per day.

III. SYSTEM DESIGN

3.1 Hardware design

Hardware design of smart pill box health care system includes various hardware like

- 12v battery,
- 5v voltage regulator
- Keypad 4x4
- ATmega16
- LCD20x4
- Ultrasonic Sensor
- Buzzer
- GSM module

Below figure shows the block diagram of smart pill box health care system.

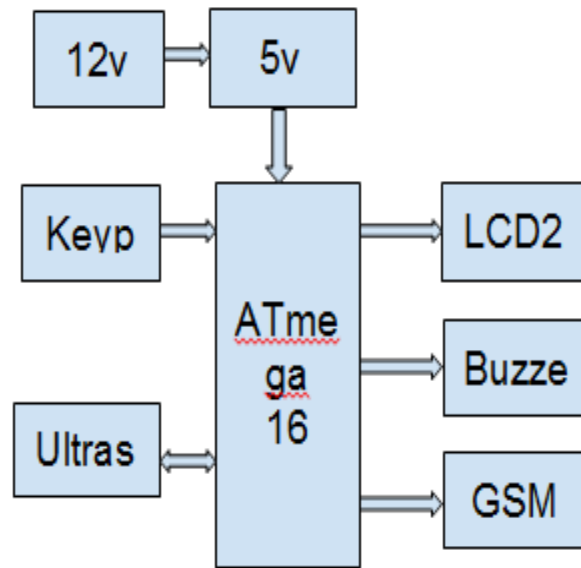

Fig 1. Block Diagram of Smart Pill Box Health Care System

From fig.1, 12v battery power supply given to the system. With the help of voltage regulator, 5v supply provide to the ATmega16 microcontroller. Now program the microcontroller with the help of AVR studio 4.0. Now, hardware components works with the help of microcontroller. Keypad 4x4 works as a input to the ATmega16 microcontroller. Similarly, LCD 20x4, Buzzer and GSM Module is a output devices which runs on the input of ATmega16 microcontroller. Ultrasonic sensor is a input as well as output with ATmega16 microcontroller.

3.2 Software design

Smart medicine box is built with an integrated software system running in the MCU. AVR Studio 4.0 is a programming platform , and programming language is standard C and WINAVR/GCC compiler. Generally, our software system can be divided into four parts, including user interface, real time clock, sound generation and LED control. User input the information for each medicine boxes and store the information in structure variables. Once the user finish initialisation,

The real time clock would keep running. After all the information has been entered. The system would enter comparison stage.

The comparison stage function would check that it compare real time with set time. When the time match the alarm will start ringing and a SMS is sent to the user mobile for medicine reminder.

Flowchart:

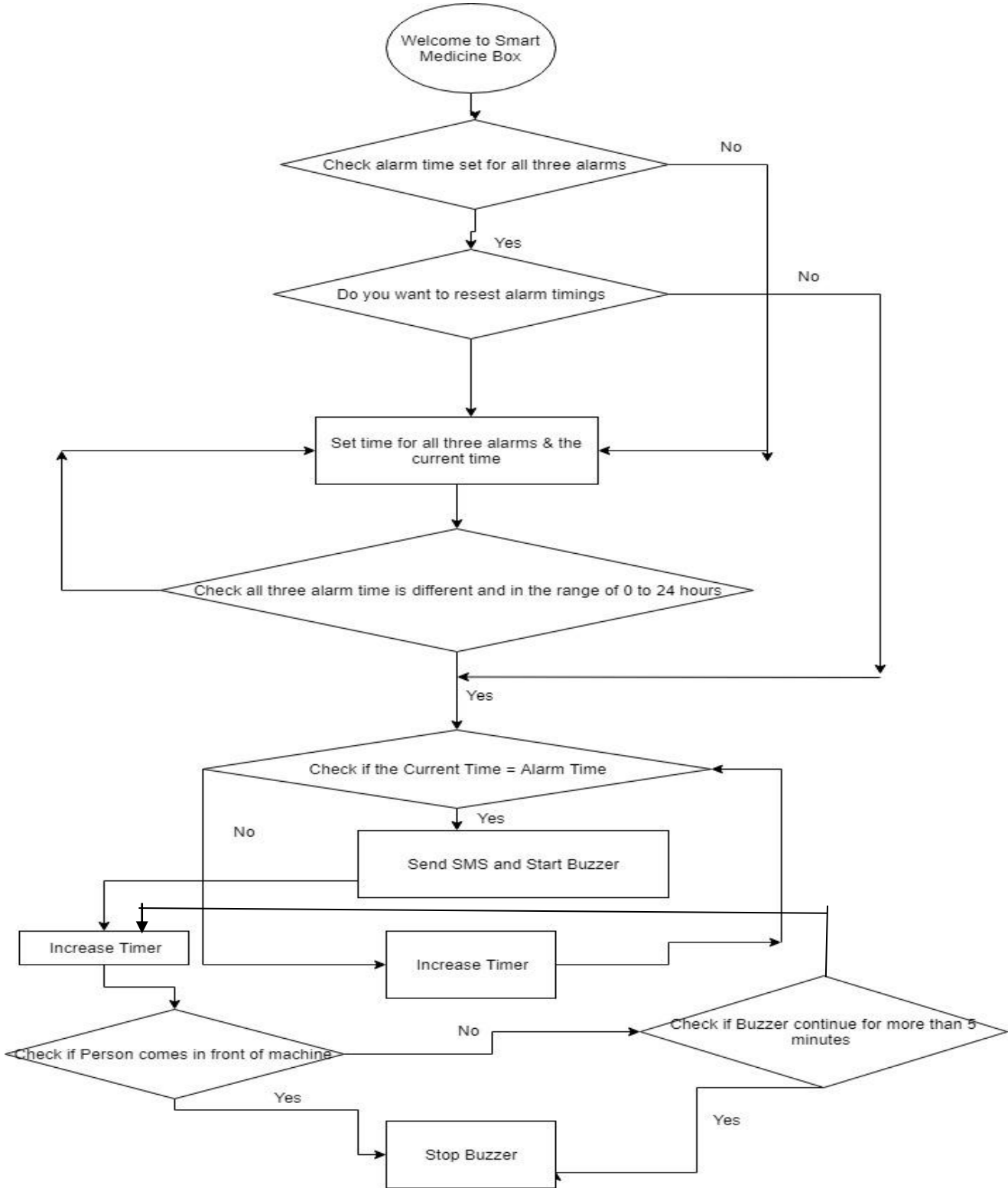

Fig 2. Flow Chart of Smart Medicine Box Health Care System

Above fig. 2 Shown the flowchart representation of “Smart Pill Box Health Care System”. When we start the system, system shows the message “Welcome to Smart Medicine Box”. After displaying the message system ask to “Check alarm time set for all three alarms”. If Yes, then reset the alarm settings or No, then set current time of the system. Now, set three alarm time is different and in the range of 0 to 24 hours. If No, then again set the three alarms and current time or Yes, then current time equal to alarm time. If No, then increase timer and again check three alarms and current time or Yes, then buzzer start and send sms. Buzzer ring till any person comes in front of the system buzzer stops or it will ring till 5 minutes and stops the buzzer.

IV. RESULT AND OPERATION STRATEGIES

As Device is switched on System shows following Initialization:



Fig.3 After Switching On the Display

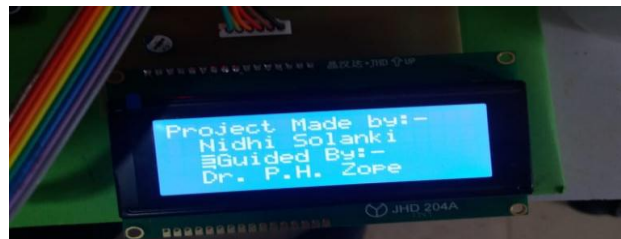

Fig.4 LCD Display

After this it will ask for time setting.



Fig.5 LCD Display

If we press A than system carried out following operation sequentially:

- 1.User initialisation stage
- 2.Comparison stage
- 3.Reminder stage

1) Initialisation stage

1.1 For alarm setting and LED indication :

- In this stage user enter current time.
- After entering, Initialisation button is pressed on the keypad present.
- Then after device enters into comparison stage.

1.2 For message :

- In this stage user add Sim card in GSM module.
- After entering, user set time and mobile number of receiver by using keypad. Then after device enters into comparison

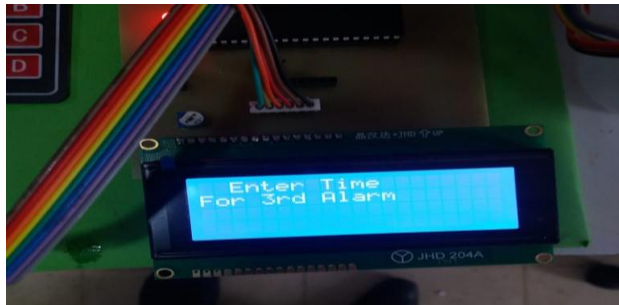

Fig.6 Initial Stage I



Fig.7 Initial Stage II

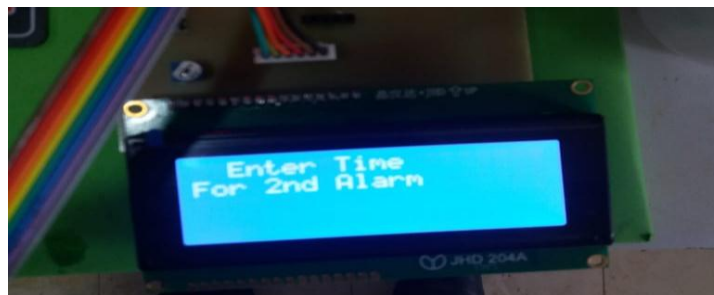

Fig.8 Initial Stage III

If we set times of morning ,afternoon and evening than system will shows this output.



Fig.9 Alarm Set

2) Comparison stage

- In this stage system compare real time clock with set time.
- Once it matches it enters into Remainder stage.



Fig.10 Current Time Display

3) Reminder stage

3.1 For alarm setting and LED indication :

- When system enter this stage, system plays audible sound.
- With audible sound, system also gives the LED indication for specified medicine.

3.2 For message :

- When system enter this stage, a message will sent through the system to the receiver.

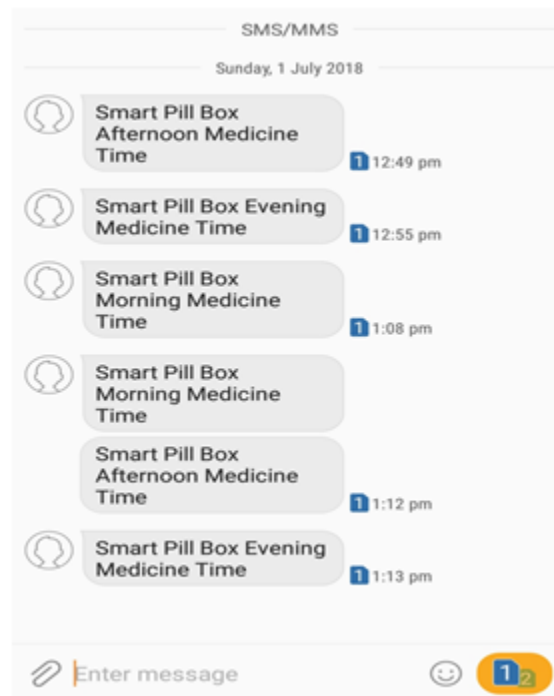

Fig.11 SMS Alert/Reminder

The device's logic structure contains three major stages those are user initialization stage, Comparison stage and reminder stage. In the user initialization stage, the user set all the initial information like current time, date and pill information (including amount and serve time for each type of pill). After finishing this work, the user press initialisation button, after this the device will enter into comparison stage. During the comparison stage, the system compares the real time with the set time of medicines. If the information entered by the user matches the real time, the system will jump out of comparison stage and enter the reminder stage. In the reminder stage, the device will continuously play sound, and the seven segments LED display will show that which subbox medicine have to take from all three sub boxes. The final performance of our device was positive. The LCD module and keypad were mounted on the surface of the box. When the power is on, the LCD would display characters like "welcome to smart pill box health care system" with the gentle yellow backlight, which allows the user to recognize the characters on the screen even in dark environment. With the implementation of this machine, the keypad responded punctually and accurately when we pressed the keypad buttons. The long press and backspace features are well during the initialization stage. The seven units of seven segment LED displays were placed on the box since they were embedded on the breadboard. During the test, we found that the light intensity for some led displays was a little different than the others, but this would not affect the users to recognize the numbers displayed. The speaker was able to produce clear and loud sound when the comparison stage was triggered. We made our paper as useful for the patient who needs this and all related users. We conclude result that our paper is useful for those people who are taking pills regularly, prescription of medicine is very long and hard to remember for those users. Our product is so useful that it can cure those patients illness and there will no need of taking care of these types of patients so caregiver has no tension about their health and they will live healthy and tension free life.

V. CONCLUSION

There is a great need for timely intake of medicines which is often skipped by many people. This Smart Pill Box helps to remind us to take medicines regularly and also which on time. Thus this implementation, though small and simple, will be a very great and useful step in the field of medicine. This paper has focused on the problems faced by senior citizens concerning adherence to their prescribed medication. It not only aids the elderly who live independently but also the caretakers of the elderly by reminding right amount of medicine at the right time. The smart medicine box has been experimentally proven to work satisfactorily. This medicine box which is a sort of semi-automatic is not only useful for geriatrics but instead it is can prove useful and a user friendly tool for all of us. It provides a greater efficiency to our paper. It helps it to be cost efficient also. The other advantage of this box is that it is very easy to use and the complexity is less. This ensures that the elderly patient

consumes the right dosage of medication at the right time, provided he or she accepts this new, unusual method of medication. The goal of our paper is to provide healthy and tension free life to those users who are taking regularly pills and to provide this product at affordable cost also. Our paper is also reusable by exchanging those other medicine box that has only alerting system and are non-usable or unaffordable compare to our product. These simple efficient techniques are supported by advancements like GSM technology to bridge the gap in communication between the supplier or the chemist and the customer or patient, thus aiding the patient.

In conclusion, this device can help and give advantage to the nurses. The main objective for this innovation is to monitor the consumption of medicine intake for intrinsic patients. It is practical in the morning and evening but also can be used at night. This device is controlled by using GSM system, so the nurse does not need go to the personal ward to give the medicine. This system is a very good to apply in the hospital because it can make the nurse job easier besides making the patients more comfortable to stay at the hospital.

The goal of this system is to provide healthy and tension free life to those users who are taking regularly pills and to provide this product at affordable cost also. This system is also reusable by exchanging those other medicine box that has only alerting system and are non-usable or unaffordable compare to our product.

ACKNOWLEDGEMENT

We are thankful to Dr K S Wani principal of SSBT's COET, Jalgaon (Maharashtra) and Dr.S R Suralkar HOD Dept. of Electronics and Telecommunication, SSBT's COET, Jalgaon (Maharashtra) to provide us guidance and encouragement to carrying out this paper work.

REFERENCES

- [1] Jayashri Ingale, Dr. P. H. Zope |Aadhar enabled ration distribution and monitoring using smart card | IJSSBT volume 6 | Number 1 | January 2018| Print: 2277-7261| Online: 2278-3857
- [2] International Research Journal of Engineering and Technology (IRJET) Volume: 03 Issue: 05 | May-2016
- [3] IJSTE - International Journal of Science Technology & Engineering | Volume 3 | Issue 10 | April 2017
- [4] Indian Journal of Science and Technology, Vol 8(S2), 189–194, January 2015
- [5] Imperial Journal of Interdisciplinary Research (IJIR) | Vol-2, Issue-5, 2016
- [6] P. H. Zope, Harshal Dahake | DESIGN AND IMPLEMENTATION OF MESSAGING SYSTEM USING BRAILLE CODE FOR VIRTUALLY IMPAIRED PERSONS | International Journal of Advanced Research in Electrical, Electronics and Instrumentation Engineering | Vol. 5| Issue 7| July 2016| ISSN (Print) : 2320 - 3765| ISSN (Online): 2278 - 8875 |DOI:10.15662/IJAREEIE.2016.0507001 -5977-5984| Impact Factor -5.62.
- [7] Snehal Thakur, P. H. Zope , Nidhi Solanki | STUDY OF WIRELESS SENSOR NETWORK FOR IOT APPLICATION | International Journal of Advanced Electronics & Communication System | Approved by CSIR-NISCAIR | ISSN No- 2277-7318 | Vol-6 No-2 (2017) | PP 6-12
- [8] Zao, J.K., Wang, M.Y., Peihuan, T. and Liu, J.W.S., (2010) "Smart Phone Based Medicine In take Scheduler, Reminder and Monitor", IEEE e-Health Networking Applications and Services (Healthcom), pp 162 - 168
- [9] International Journal of Scientific & Engineering Research, Volume 7, Issue 5, May-2016
- [10] IJSTE - International Journal of Science Technology & Engineering | Volume 3 | Issue 10 |April 2017.
- [11] International Conference on Applied Electronic and Engineering 2017 (ICAEE2017)

- [12] Deepti Ameta, Kalpana Mudaliar and Palak Patel, (2015) "Medicine Reminder and Healthcare – An Android Application", International Journal of Managing Public Sector Information and Communication Technologies, Vol. 6, No. 2
- [13] Viral Shah, Jigar Shah, Nilesh Singhal, Harsh Shah & Prof. Prashant Uapdhyay, "Smart Medicine Box", Imperial Journal of Interdisciplinary Research (IJIR), Vol-2, Issue-5 ,2016.
- [14] Aakash Sunil Salgia*, K. Ganesan and Ashwin Raghunath, "Smart Pill Box", Indian Journal of Science and Technology, Vol 8(S2), 189–194, January 2015.
- [15] Naga Udayini Nyapathi 1, Bhargavi Pendlimarri 2, Karishma Sk3 , Kavya Ch4," Smart Medicine Box using ARM7 Microcontroller", International Research Journal of Engineering and Technology(IRJET) , Volume: 03 Issue: 05 | May-2016.
- [16] P. H. Zope, Harshal Dahake | Design and Implementation of Messaging System Using Braille Code for Virtually Impaired Persons | International Journal of Advanced Research in Electrical, Electronics and Instrumentation Engineering | Vol. 5 | Issue 7 | July 2016 | ISSN (Online): 2278 – 8875 | Impact Factor-5.621.
- [17] Bhushan N. Patil, P. H. Zope, K. S. Patil | Development of Low Cost TDR System for Soil Moisture Measurement |International Journal of Advanced Research in Education & Technology| Vol. 2| Issue 3| July to Sept-2015| Impact Factor-1.568.
- [18] Smart Medication Dispenser: Design, Architecture and Implementation- Pei-Hsuan Tsai, Tsung-Yen Chen, Chi-Ren Yu, Chi-Sheng Shih, Member, IEEE, and Jane W. S. Liu, Fellow,IEEE.
- [19] International Journal of Science and Research (IJSR) Volume 6 Issue 1, January 2017 .