

Comparative Analysis of Performance of D-STATCOM and DVR for Voltage sag, Voltage swell and Fault compensation

NAGESH M¹, NANDINI S KODIHALLI²

¹PG Student, Dept. of EEE, The National Institute of Engineering, Mysuru, Karnataka, India

²Assistant Professor, Dept. of EEE, The National Institute of Engineering, Mysuru, Karnataka, India

Abstract – In this sophisticated era, without electricity, modern society would cease to function. The volume of power transmitted and distributed increases with high quality and reliable power supply. At the same time, rising costs and growing environmental concerns make the process of building new power transmission and distribution lines increasingly complicated and time-consuming. The power quality becomes one of the major considerations in the power system. It has become important especially with the introduction of the advanced devices. These advanced devices are more sensitive to the quality of the power supply. The power quality refers the voltage, current, and frequency at the rated value. If any variation occurred in these quantities with respect to the standard rating is considered as the power quality problems. The power quality problems like voltage sag or voltage dip, voltage swell and harmonic distortion causes a failure of the end-user types of equipment of the customers. In order to overcome these power quality problems, we prefer to use the custom power devices at the distribution side. Among different custom power devices, DVR and D-Statcom are preferred to use for increasing the power quality, because of their simple construction and less complexity. The paper presents comparative analysis of the D-Statcom and DVR by using MATLAB Simulink software.

Keywords: D-STATCOM, DVR, Power quality, Power quality solutions, MATLAB/SIMULINK

1. INTRODUCTION

One of the major considerations in today's electrical industry is the power quality. The issue in electricity power sector delivery is not confined to only energy efficiency and environment but more importantly on quality and continuity of supply or power quality and supply quality. In recent days electrical power systems are becoming the more complex network with a number of generating stations and a large number of load centers are connected through the long power transmission and distribution network. Quality of the power is the major concern in today's industries. Because of excessive losses in energy, and these energy losses leads to financial losses. With the occurrence of number of the sophisticated electrical and electronic equipments are more sensitive to the disturbances and non-linear loads [6]. At the distribution system side they produce much power quality problems like voltage sag, swell and harmonics and also the purity of the sine waveforms are lost. Voltage sag or voltage dip is considered as one of the most severe and common disturbances as compare to other power quality problems [3]. Excessive reactive power demand increases

the ohmic losses and reduces the active power flow capability of the distribution system, whereas voltage unbalance has an adverse impact on the operation of transformers and generators [2].

The power distribution systems should provide an uninterrupted power supply to their customers at a rated value of the voltage with continuous sinusoidal waveform. Increasing of a voltage at the load, can be accomplished by injecting the reactive power at the load of PCC. The reactive power compensation is very much important for prevailing the load demands. And these will make the system more compatible to increase the reliable distribution by changing the nature of the electrical characteristics. Under light load and heavy load conditions, the voltage level has to be maintained by using shunt connected mechanically or fixed switched reactors. The most common method for achieving this is to install mechanically operated shunt capacitors connected to the primary terminal of the distribution transformer. The mechanically operated switching may be on a schedule through the signals from the SCADA system [4]. The main disadvantage is, the compensation of the high speed transients is not possible with the help of mechanically operating switches and also within the time frame some sags are not compensated. Transformer taps can be used, but changing the taps under loading conditions are costly. The shunt and series compensation are used to improve the system performance [3].

The ultimate goal of applying the shunt compensation is to increase the transmission power in a transmission system. Shunt compensation can also be used to increase the quality of the power and also the stability of the system. In series compensation the automatic change in the reactive power along with load current can be achieved with the help of series capacitor. Thus due to sudden load variations voltage drops in the system can be corrected. In an already existing parallel line, it is difficult to introduce the new line for capable of transferring the large power without overloading the older line. Series compensation increases the stability of the system by decreasing the value of the series impedance in the uncompensated line. And hence the same power can be transferred from sending end to the receiving end [7].

By using power electronic devices also we can achieve the voltage regulation by considering some custom power devices like D-Statcom and DVR. These custom power devices providing the power quality at reliable distribution. D-Statcom is shunt connected device and DVR

is series connected device which is used to regulate the system voltage. These voltage regulations are mainly for sensitive loads that may be intensely affected by fluctuations in the system voltage.

2. POWER QUALITY

Power quality is a set of electrical boundaries that allows a piece of equipment to function in its intended manner without significant loss of performance or life expectancy. Power quality includes all possible situations in which the waveforms of the supply voltage or load current deviate from the sinusoidal waveform at rated frequency with amplitude corresponding to the rated rms value for all three-phases system [1].

Power quality disturbance covers sudden, short duration deviation impulsive and oscillatory transients, voltage dips (or sags), short interruptions, as well as steady-state deviations, such as harmonics and flicker [2].

3. WHY WE NEED POWER QUALITY?

The main reason that we are interested in power quality is economic value. There are economic effects on utilities, their customers, and suppliers of load equipment. The quality of power can have a direct economic effect on many consumers. This usually means electronically controlled, energy efficient equipment that is often much more sensitive to variation in the supply voltage. Residential customers typically do not suffer direct economic loss or the helplessness to earn income as a result of most power quality problems, but they can be a potent force when they understand that the utility is providing poor service. Many manufacturers are also unaware of the types of disturbances that can happen on power systems. The primary responsibility for correcting shortage in load equipment ultimately lies with the end user who must purchase and operate it. Specifications must include power performance criteria. Since many end users are also unaware of the danger, one useful service that utilities can provide is especially information on power quality and the requirements of load equipment to properly operate in the real world.

4. POWER QUALITY PROBLEMS

4.1 Voltage Sag

A voltage sag or voltage dip is a decreasing the value of the RMS voltage for a short duration of the time. When the voltage sag occurs the value of the RMS voltage is decreased to 10% - 90% of the nominal value of the RMS voltage. Some references defining that voltage sag occurs for a time period of half cycles to one minute. If the duration of voltage sag exceeds more than one minute is called as sustained sag [8].

The main reason of the voltage sag is the fault occurred in the parallel feeder or sudden connection of the heavy loads.

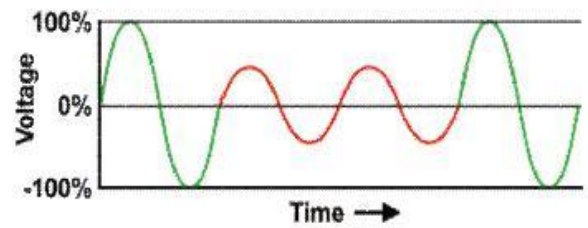

Fig.1 Voltage Sag

4.2 Voltage Swell

A voltage swell is an increase in the value of the RMS voltage for a short duration of the time. When the voltage swell occurs, the RMS value of the voltage is increased more than 110% of the nominal RMS value of the voltage. Some references defining that, the voltage swell occurs for a time period of half cycles to one minute [20].

The main reason of the voltage swell is the disconnection of the heavy loads.

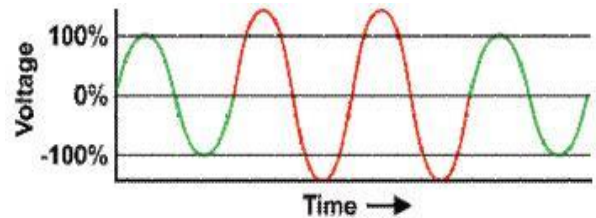

Fig.2 Voltage Swell

4.3 Faults in power system

Single line to ground (SLG) fault:

This fault is most commonly occurring and less severe fault as compared to other types of faults. The chances of a fault occurring is 65%-70%. The SLG fault occurs when any one of the lines or conductor fall on the ground or make in contact with the neutral conductor. Since it is unbalanced fault it causes unbalanced conditioning in a system and leads the damage to the equipments.

Double line to ground (DLG) fault :

15% to 20% of the fault consisting of DLG fault. This fault is occurring when any two lines are getting short-circuited and make contact with the ground. Whenever this fault occurs system became unbalanced and cause more serious damage to the system as compared to SLG fault.

Line to line (LL) fault:

This is uncommon fault in the symmetrical faults. And chances of occurring of this fault are only 5% - 10%. When two lines are short-circuited is called as line to line fault. In this fault the current is circulating within short circuited lines. This fault is more severe compared to double line to ground fault.

Symmetrical faults are very severe and rarely occurring fault. And these faults can also called as balanced faults namely,

Three phase to ground fault:

Three phase fault and chances of occurring this fault is 2%-3%. Because even under fault condition the system remains in the balanced condition. But equipments in the system are severely damaged.

In a three phase system the load is said to be unbalanced due many reasons such as, due to sudden connection and disconnection of heavy loads, unreliable power supply from the grid, due to long distance power supply from the distribution transformer with interrupted loads, And also necessity of boosting the power supply to the remote location. In all these cases disturbance of voltage is mainly depends on voltage sag, different types of fault and voltage swell. If the problems are not cleared within a limited time frame it leads brownout or blackout condition to the system [14]. Therefore in this work voltage sag, short circuit faults in power system and voltage swell is considered as the power quality problems.

5. SOLUTIONS TO THE POWER QUALITY PROBLEMS

Energy storage system is the best solution for power quality problems as compare to other solutions. Because it will compensate the missing or interrupted power in an electrical system. The different methods are used for mitigate the voltage sag and voltage swell. The most effective method is using the custom power devices. For example, FACTS devices are used for transmission systems. The custom power device uses the power electronics controllers in the distribution system to deal with different power quality problems. In this work the D-STATCOM and DVR are considered as custom power devices, in D-STATCOM and DVR the DC-link device is considered as power source. DC link means the electrical energy is supplied by the DC bus to voltage source inverter. By using this method we can get proper solution over power quality problems.

Various power quality issues and remedies have been listed out in this chapter. Power system faults are explained with their typical waveforms. Best solution for the power quality problems is the application of the power electronic devices to improve the voltage and avoid surges. D-STATCOM and DVR are such devices and their operation with different loading conditions can be seen in future chapters.

6. D-STATCOM

The voltage sags are most commonly occurring problems in power quality. Even though the power outages are worse in industry than the voltage sag, it is considered a serious problem and it finally leads to financial losses. In higher voltage level the voltage dips are a serious problem. In overhead lines sudden decreasing the value of voltage occurs mainly due to lightning effect. The mitigation of the disturbances is profitable if the financial losses are

considered as more significant [13]. There is no unique or standard solution which will work in all sites, every mitigation actions are carefully designed and evaluated. There are different solutions are there for mitigating voltage sag, interruptions and voltage swells in distribution system. In recent days the custom power devices are playing the vital role for mitigating the power quality problems. D-STATCOM is one of the custom power device used to overcome these power quality problems.

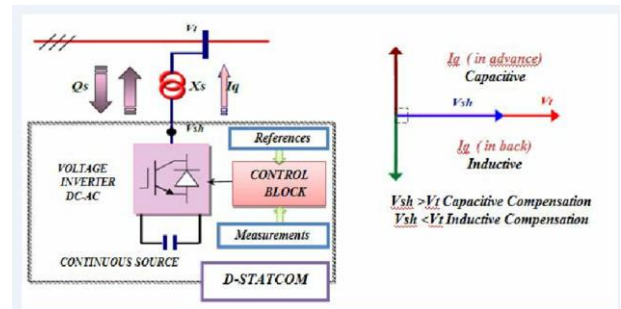

Fig.3 Basic structure of D-Statcom

The principle and operation of the D-Statcom are explained in above figure

Where V_{sh} be the voltage of the IGBT converter is controlled in phase with the system voltage (V_t) and depending on (V_{sh}) value the value of the current output of the D-Statcom (I_q) is varied.

1. $V_t < V_{sh}$: The value of I_q is leading with respect to 90-degree phase angle of V_t . Hence, the system will be in capacitive mode and the reactive power is flowing from the D-Statcom to the system.
2. $V_t > V_{sh}$: The value of I_q is lagging with respect to by 90-degree phase angle of V_t . In this case, it acts as the inductive mode. And the D-STATCOM will absorb the reactive power.
3. $V_t = V_{sh}$: In this case, there is no exchange of the reactive power from the system to the D-Statcom.

By changing the value of the voltage across the capacitor the magnitude of the value of the output voltage can also be changed. Independent of network voltage the capacitive or inductive current which is injected by the D-Statcom. Even at the lower voltage values, it can provide the maximum capacitive current. Compare to SVC it is having the ability to supply the better voltage. D-Statcom can increase the inductive and capacitive current temporarily. The important advantage of the D-Statcom is able to exchange the capacitive and inductive energy with the system.

6.1 single line diagram of d-statcom connected to the system

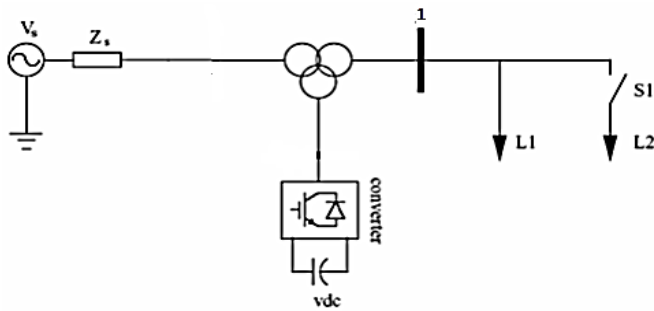

Fig. 4: Single line diagram of D-Statcom connected to the system

The above Fig. 4 represent the single line diagram of the D-Statcom. It consisting of the source voltage (V_s), source impedance (Z_s) and three phase three winding transformer. Where the source voltage is connected to the primary winding of the transformer and transformer secondary is connected to the load. The load is divided into load1 (L1) considered as sensitive load and load 2 (L2) considered as a heavy load. Transformer tertiary winding is connected to the D-Statcom which is consists of converter with parallel connecting DC source voltage. The main aim of the D-Statcom is, protecting the sensitive loads from power quality problems. At a point of common coupling (1) measures the system voltage [2].

7. DYNAMIC VOLTAGE RESTORER

DVR is recently introduced solid-state device connected in series. And used to regulate the voltage in the load side DVR will inject voltage into the system [15]. The DVR is to be located at a point of common coupling where the supply system and critical loads connected. DVR can also add some additional feature like limiting the fault current, voltage harmonics compensation.

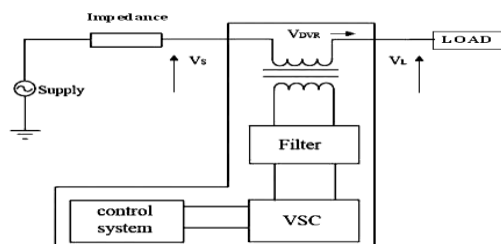

Fig.5 General Configuration of DVR

The DVR can be operated in three modes which are explained as

Bypass mode - Dynamic Voltage Restorer (DVR) is bypassed mechanically or electronically during short circuit and high load conditions. In bypass mode the DVR cannot inject voltage in order to compensate voltage disturbance.

Standby mode - The DVR is ready to compensate the voltage disturbance when the value of the supply voltage is at rated level of DVR. In this mode the DVR has following tasks,

Loss less mode: In DVR the conduction losses are minimized due to no switching performance.

Harmonic blocking mode and voltage balancing mode: The DVR perform switching action and it expected to injecting small voltage hence it compensate the poor background of voltage.

Capacitor emulation mode: The large line inductance can be compensated effectively by controlled operation of the DVR inserted with series capacitor.

Active mode - The DVR is injecting the missing voltage whenever voltage sags are detected. In this mode voltage with minimum energy dissipation should ensure by the DVR for injection with high cost of capacitor. The injection of voltage can be achieved in different methods, they are listed below [12].

7.1 Location of DVR

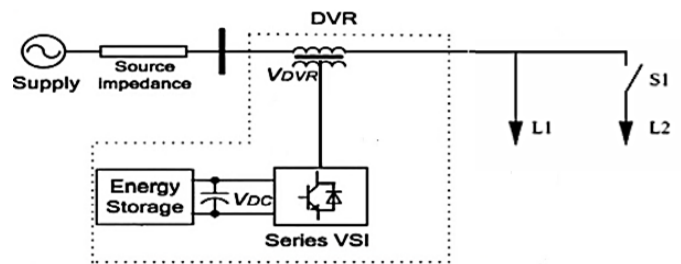

Fig. 6 Location of DVR

The above Fig. 6 represent the location of the DVR. It consists of the source voltage (V_s), source impedance (Z_s) and three phase two winding transformer. Where the source voltage is connected to the primary winding of the transformer and transformer secondary is connected to the load. The load is divided into load1 (L1) considered as sensitive load and load 2 (L2) considered as a heavy load. Transformer tertiary winding is not used as in case of D-Statcom. Hence DVR is directly connected in series with line with the help of injection transformer. The main aim of the DVR is, protecting the sensitive loads from power quality problems. At a point of common coupling measures the system voltage [26].

8. COMPARISON BETWEEN PERFORMANCE OF D-STATCOM AND DVR

In recent days the improvement of power quality becomes the major concern in power system. The increasing power quality demand is made by increasing the sophisticated and sensitive loads. The custom power devices are best option to improve the quality of power. D-STATCOM and DVR are custom power devices are used to improve the quality of the power in a distribution system. The

magnitudes of the voltage at the load are used to analyze the performance of the devices.

CASE-1: DIFFERENT TYPES OF FUALTS COMPARISON BETWEEN D-STATCOM AND DVR COMPENSATION

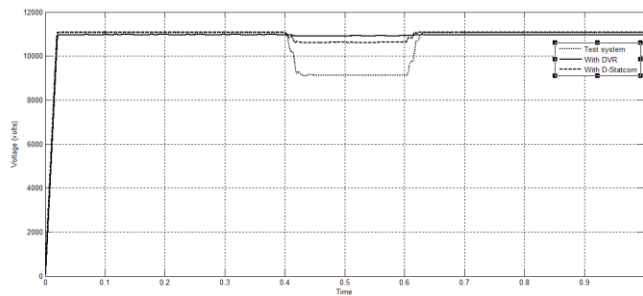

Fig.7 PCC voltage magnitude for SLG fault with and without connecting D-Statcom and DVR

SLG fault is created in a system consisting of with and without D-Statcom and DVR. After connecting D-Statcom and DVR the value of the voltage increases for compensating the voltage sag.

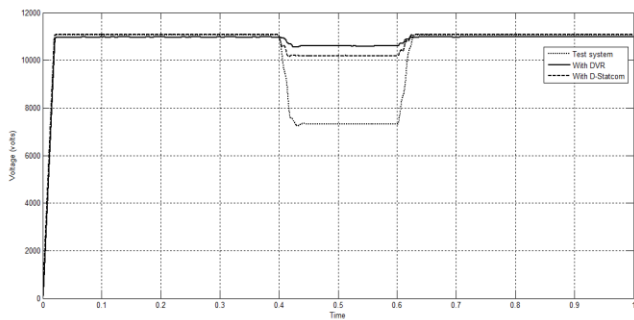

Fig.8 PCC voltage magnitude for DLG fault with and without connecting D-Statcom and DVR

DLG fault is created in a system consisting of with and without D-Statcom and DVR. After connecting D-Statcom and DVR the value of the voltage increases for compensating the voltage sag.

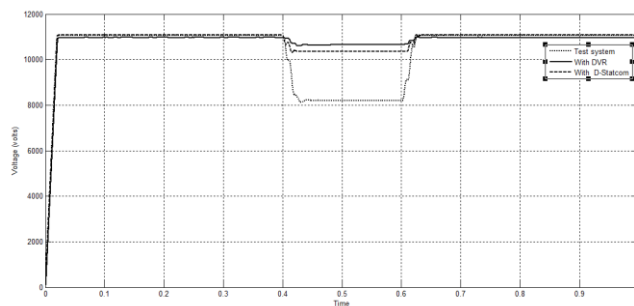

Fig.9 PCC voltage magnitude for LL fault with and without connecting D-Statcom and DVR

LL fault is created in a system consisting of with and without D-Statcom and DVR. After connecting D-Statcom and DVR the value of the voltage increases for compensating the voltage sag.

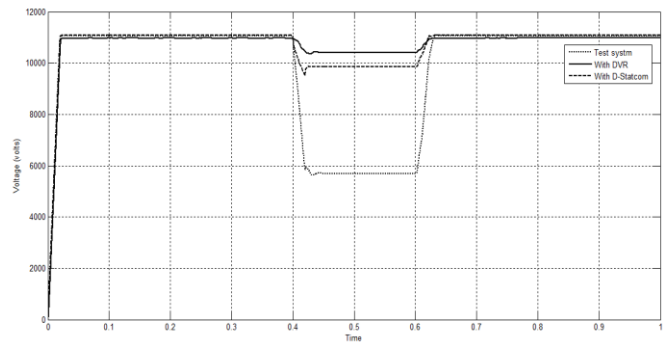

Fig.10 PCC voltage magnitude for TLG fault with and without connecting D-Statcom and DVR

TLG fault is created in a system consisting of with and without D-Statcom and DVR. After connecting D-Statcom and DVR the value of the voltage increases for compensating the voltage sag.

TABLE 1: Comparison of different types of fault compensation between D-STATCOM and DVR

TYPES OF FAULTS	TEST SYSTEM VOLTAGE (in volts)	WITH D-STATCOM VOLTAGE (in volts)	WITH DVR VOLTAGE (in volts)
SLG	9140	10600	10900
LL	8200	10300	10850
LG	7300	10200	10800
TLG	5700	10000	10400

CASE-2: COMPARISON BETWEEN D-STATCOM AND DVR COMPENSATION RESULTS FOR VOLTAGE SWELL

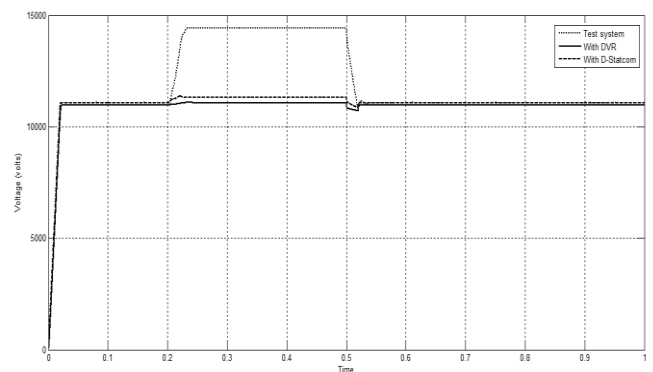

Fig.11 Load voltage magnitude of system with and without connecting D-Statcom and DVR when the system is unloaded up to 190MW

In this waveform, the system is unloaded up to 190MW during 0.2 second to 0.5 second of time period, and causes voltage swell. After connecting D-Statcom and DVR the voltage swell is mitigated.

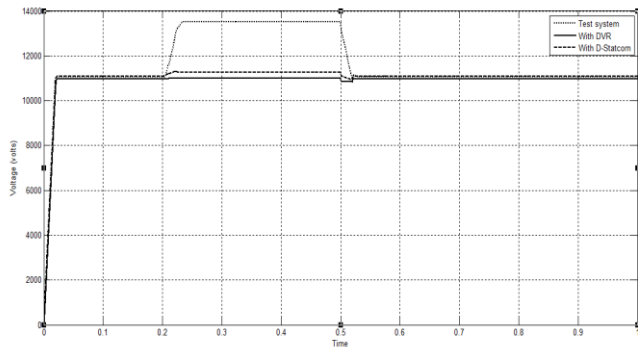

Fig.12 Load voltage magnitude of system with and without connecting D-Statcom and DVR when the system is unloaded up to 150MW

In this waveform, the system is unloaded up to 150MW during 0.2 second to 0.5 second of time period, and causes voltage swell. After connecting D-Statcom and DVR the voltage swell is mitigated.

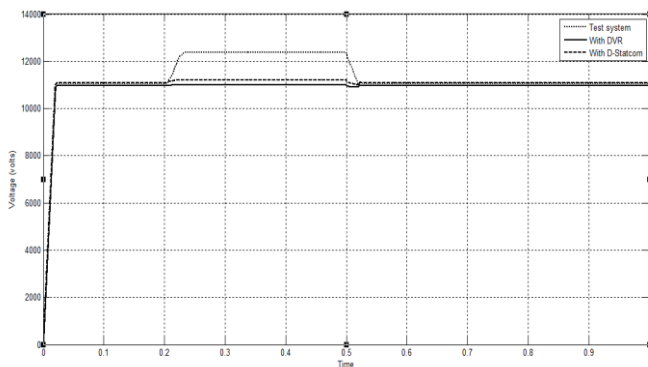

Fig.13 Load voltage magnitude of system with and without connecting D-Statcom and DVR when the system is unloaded up to 100MW

In this waveform, the system is unloaded up to 100MW during 0.2 second to 0.5 second of time period, and causes voltage swell. After connecting D-Statcom and DVR the voltage swell is mitigated.

TABLE 2: Comparison of voltage swell mitigation between D-STATCOM and DVR

CASE	UNLOADING (in MW)	TEST SYSTEM VOLTAGE (in volts)	WITH D-STATCOM VOLTAGE (in volts)	WITH DVR VOLTAGE (in volts)
1	190	14400	11320	11100
2	150	13400	11260	11050
3	100	12300	11200	11000

CASE-3: COMPARISON BETWEEN D-STATCOM AND DVR COMPENSATION RESULTS FOR VOLTAGE SAG

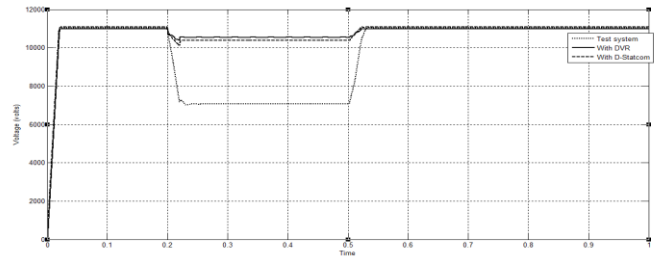

Fig.14 Load voltage magnitude of system with and without connecting DVR and D-Statcom when the system is loaded up to 190MW

In this waveform, the system is loaded up to 190MW during 0.2 second to 0.5 second of time period, and causes voltage sag. After connecting D-Statcom and DVR the voltage sag is compensated.

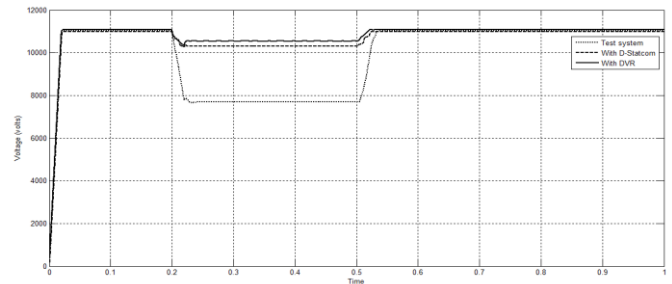

Fig.15 Load voltage magnitude of system with and without connecting DVR and D-Statcom when the system is loaded up to 150MW

In this waveform, the system is loaded up to 150MW during 0.2 second to 0.5 second of time period, and causes voltage sag. After connecting D-Statcom and DVR the voltage sag is compensated.

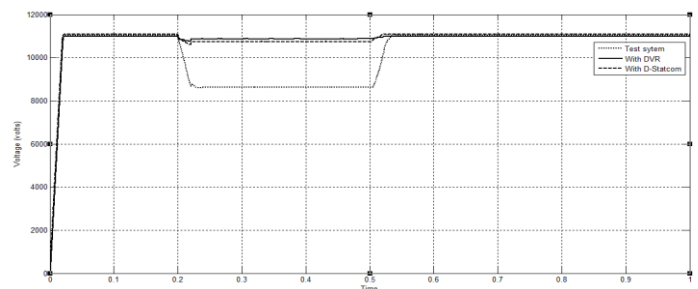

Fig.16 Load voltage magnitude of system with and without connecting DVR and D-Statcom when the system is loaded up to 100MW

In this waveform, the system is loaded up to 100MW during 0.2 second to 0.5 second of time period, and causes voltage sag. After connecting D-Statcom and DVR the voltage sag is compensated.

TABLE 3: Comparison of voltage sag comparison between D-STATCOM and DVR

CASE	UNLOADING (in MW)	TEST SYSTEM VOLTAGE (in volts)	WITH D- STATCOM VOLTAGE (in volts)	WITH DVR VOLTAGE (in volts)
1	190	7100	10300	10400
2	150	7700	10550	10450
3	100	8600	10750	10900

9. CONCLUSION

In this paper, the comparison between D-Statcom and DVR is accomplished by using MATLAB/SIMULINK software. The result obtained from the simulation clearly shows that it is more interesting on custom power devices in order to improve the quality of the power. The performance of D-Statcom and DVR to mitigate the voltage swell, voltage sag and also different kinds of faults for different cases are carried out in simulation software effectively. By considering the results obtained from this project work finally we can conclude that DVR shows the better efficiency and effectiveness on voltage swell, voltage sag and also different kinds of fault compensation as compared to D-Statcom. The objective of the project has been achieved.

REFERENCE

- [1] B.V.Rajanna¹ , Rami Reddy CH² , Dr.K.Harinadha Reddy "Design, Modeling & Simulation of DSTATCOM for Distribution Lines for Power Quality Improvement" *Journal of Electrical Engineering*.
- [2] R.K.Rojin "A Review of power quality problems and solutions in electrical power system" *International Journal of Advanced Research in Electrical, Electronics and Instrumentation Engineering* ISO 3297: 2007
- [3] Meenakshi Rastogi, Abdul Hamid Bhat, Aijaz Ahmad Zargar. "Performance evaluation of DSTATCOM for mitigation of power quality problems at different source and load side fault conditions", IEEE 7th Power India International Conference (PIICON), 2016
- [4] I.H. Song, H.S. Shin, C.H. Choi, J.S. Chai, Y.S. Kim. "Development of highly stabilized & high precision power supply for KCCH cyclotron magnet", PPPS-2001 Pulsed Power Plasma Science 2001. 28th IEEE International Conference on Plasma Science and 13th IEEE International Pulsed Power Conference. Digest of Papers 2001
- [5] S.R. Reddy, P.V. Prasad, G.N. Srinivas. "Balanced voltage sag & swell compensation by using dynamic voltage restorer", 2016 IEEE 1st International Conference on Power Electronics, Intelligent

Control and Energy Systems(ICPEICES), 2016

- [6] Rajasekaran. "ARTIFICIAL NEURAL NETWORK CONTROLLER BASED DISTRIBUTION STATIC COMPENSATOR FOR VOLTAGE SAG MITIGATION", *American Journal of Applied Sciences*, 2013
- [7] Y.S. Cho, H.S. Choi, B.I. Jung. "Operational characteristics in the three-phase transformer type SFCL with neutral line based on sequential reclosing process", *Physical C: Superconductivity and its Applications*, 2011
- [8] "Power Electronics and Renewable Energy Systems", Springer Nature, 2015

