

# Mitigation of Harmonic Power Flow in Unbalanced and Polluted Radial Distribution System by using IEEE 13, 37 and 123 Test Bus System

Sandhya Singh<sup>1</sup> and Ashish Bhargava<sup>2</sup>

<sup>1</sup>Research Scholar Mtech

<sup>2</sup>Professor, Bhabha Bhopal

\*\*\*

**Abstract** - Radial distribution systems (RDS) require special load flow methods to solve power flow equations owing to their high R/X ratio. Increasing use of power electronic devices and effect of magnetic saturation cause harmonics in RDS. This dissertation proposes a novel algorithm to compute the power flow solution of a RDS accounting for all the harmonic components. It uses a recursive solution technique. The proposed method uses a novel dynamic data structure reported in the paper. The proposed method is tested upon a 13, 37 and 123 bus system and the results are reported.

**Key Words:** Radial distribution system, Magnetic saturation, Harmonics, Dynamic Data Structure.

## 1. INTRODUCTION

Investigation of dispersion frameworks utilizing power stream is critical in the field of energy frameworks. Dissemination frameworks are dominantly described by their high R/X proportion and spiral topology. Grid based iterative strategies don't loan themselves for outspread circulation frameworks attributable to these qualities. Various calculations have been created utilizing basic recursive conditions [1-3]. Quick industrialization has prompted expanding utilization of energy electronic gadgets in transmission and conveyance frameworks. Present day modern and local buyers utilize a consistently expanding number of gadgets that fundamentally utilize control hardware-based power-conditioners. Utilization of AC machines utilizing attractive circuits in the soaked district likewise presents sounds in electric power frameworks. Various power stream techniques have been accounted for in writing that is intended to deal with sounds [4]. These techniques at times address outspread conveyance frameworks.

Load stream computation in consonant contaminated spiral framework with dispersed age has been done utilizing theoretical information writes with complex parameters [5].

A various recurrence three-stage stack stream with two sub models including the major power stream (FPF) and consonant recurrence control stream (HPF) show has been produced and the standard Fourier investigation was utilized to manage the symphonious burdens to get infusion ebbs and flows [6]. Fluffy number-based technique for consonant load-stream count including vulnerabilities has been connected for interconnected framework [7].

From the over, one may see the requirement for an effective calculation that dependably fathoms the power stream conditions for outspread dissemination frameworks portrayed by high R/X proportion, spiral topology and consonant burdens. Vast circulation frameworks utilize supervisory control and information obtaining (SCADA) frameworks for effective administration. SCADA frameworks utilize control stream arrangements strategies to determine the condition of the appropriation framework. Dissemination Load Flow (DLF) additionally shapes a basic piece of calculations that survey the cost and advantage of transformer taps changes, change in static Var settings, reconfiguration of the framework for different purposes extending from stack adjusting, loadability upgrade, appropriation misfortune minimization, and voltage profile change among a few others. Existing strategies for dispersion stack stream use look into tables as well as load tables and additionally switch tables with the end goal of framework portrayal. Reconfiguration and different activities render the look into table-based portrayal plans insufficient.

MATLAB approach has been connected for consonant load stream investigation of a circulation framework [8]. This paper proposes a dynamic information structure (DDS) that stores data of a branch of a RDS to decide the transport voltages and point of a specific load design for a given request of sounds. This DDS is adjustment of the DDS detailed in [9]. These DDS are taken care of as a connected rundown speaking to the whole spiral dissemination framework.

A pseudo code that creates the DDS for a RDS is exhibited. A capacity is then built up that registers the voltages from the farthest wind up to the leader of the branch. This capacity is gotten recursively to discover voltages at all branches of the RDS from the farthest branch up to the branches exuding from the primary substation of the RDS. A pseudo code for this recursive capacity is likewise introduced. The subsequent DLF calculation is computationally effective and can manage the topology changes rapidly. The proposed technique permits demonstrating of heaps of any kind, any number of symphonious segments and outspread arrangement of any design concerning transports and branches. 1.2 Proposed Harmonic Distribution Load Flow

Distribution power flow is presented in this section. It uses the dynamic data structure proposed in Section 2. First the line model of a generic line is presented with modelling for

harmonics. Then a recursive algorithm is presented. This is followed by the flowchart of the proposed harmonic distribution load flow.

## 2. LITERATURE REVIEW

The various literature associated to ‘mitigation of harmonic power flow in unbalanced and polluted radial distribution system by using IEEE 13, 37 and 123 test bus system’ has been surveyed in various IEEE transactions, journals, Conference papers and websites and also, their relationship with present research work.

**Bitar Arabsalmanabadi [2017]:** The main purpose of this paper is the harmonic power flow in multiphase unbalanced radial distribution systems in the presence of non-linear loads and reactive components. It is important to have analytical methodologies to assess the impact and consequences of non-linear loads and shunt capacitors on voltage profile and harmonic distortion in each bus in the power systems. The presented power flow is entirely different from conventional methods applied in transmission power systems. The proposed method in this paper is based on graph theory, and injection current technique. A standard test system, IEEE-13 bus radial unbalanced, is considered for implementation and explanation of the method. To check the accuracy and efficiency of the method, it is also tested on IEEE 34, 37 & 123 bus test feeders. The comparison of results approves robustness and reliability of the method. MATLAB M-file is used to obtain results.

**Bo Chen [2017]:** In this paper, a sequential service restoration (SSR) framework is proposed to generate restoration solutions for distribution systems and microgrids in the event of large-scale power outages. The restoration solution contains a sequence of control actions that properly coordinate switches, distributed generators, and switchable loads to form multiple isolated microgrids.

**Hamed Ahmadi [2016]:** In this paper, a three-phase linear power flow (3LPF) formulation is derived based on the fact that in a typical distribution system, voltage angles and magnitudes vary within relatively narrow boundaries.

**Alireza Javadi [2016]:** This paper contributes to improvement of power quality for a modern single-phase system and emphasis integration of a compensator with energy storage capacity to ensure a sustainable supply.

**Abner Suchite Remolino [2016]:** In this paper is shown a new version of this method, called LRSV (Lemus Ruiz Suchite Viramontes method). This method gets the nodal voltage solutions faster than all FBS (forward/backward sweep) existing methods until now. First is explained how LRV method works, next is explained how a renumbering process improve this method and make it suitable to analyse every radial configuration.

**Guangzheng Yu [2016]:** A probabilistic method based on  $2m+1$ PEM for PHPF has been proposed to evaluate the

distribution of harmonic when DGs accessing to grid. This method takes into account the uncertainty including amplitude of harmonic current injection source.

**Alireza Javadi [2015]:** This paper assists the energy management and power quality issues related to electric transportation and focuses on improving electric vehicles loads connection to the grid. The control strategy is designed to prevent current harmonic distortions of non-linear loads to flow into the utility and corrects the power factor of this later.

**Ritam Misra [2015]:** This paper studies the impact of PEVs on harmonic distortions and integration of WGs to reduce it. A harmonic decoupled power flow model is developed, where PEVs and WGs are represented by harmonic current loads and sources, respectively. The developed model is first used to solve harmonic power flow on IEEE 34-node distribution test feeder with low, moderate, and high penetrations of PEVs, then its impact on total harmonic distortions (THDs) is studied.

## 3. UNBALANCED RADIAL DISTRIBUTION SYSTEM

Load stream investigation of Unbalanced Radial Distribution System is of an incredible matter of arrangement, since because of unbalancing of either 3-stage or 2-stage framework the impact of shared impedance term will emerge when we register the voltage of a transport. Unbalance framework prompts common impedance as well as connect with other framework likewise like a telephonic framework, which prompts undesirable obstruction between both the frameworks. We should consider a lopsided 3 stage conveyance framework display and comprehend the ideas and investigations it numerically. Fig. 3.1 presentations a 3- $\phi$  line segment and the line parameters can be accomplished by the procedure created via Carson and Lewis. A  $4 \times 4$  lattice, which depict the couplings impacts of self and shared impedances of the un-adjusted 3- $\phi$  line segment, can be communicated as:

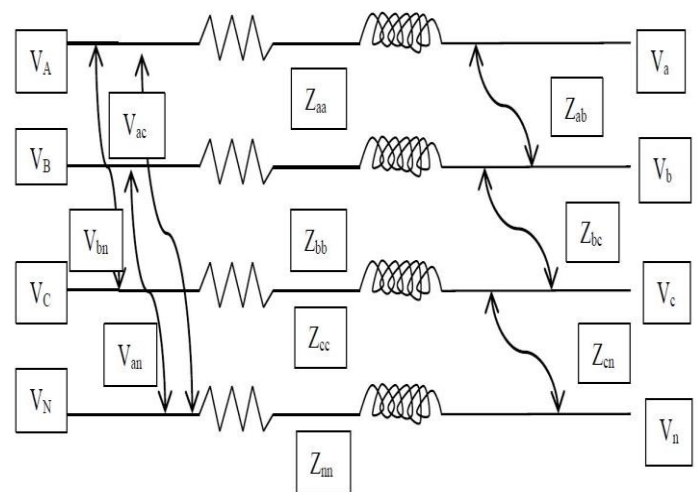

Fig. 3.1 Three Phase Line Section Model

#### 4. IMPLEMENTED WORK

The following method is proposed to study the effectiveness of mitigation of harmonic flow in unbalanced and polluted radial system by using IEEE 13, 37 and 123 test bus system which is built in MATLAB. Then, continuation power flow analysis is performed on the system built by using MATLAB. The bus type such as load bus, generator bus and slack bus are specified by using quantities such as active power, reactive power, voltage magnitude and load angle which is specified in different buses and used to have an understanding of the voltage stability of the system. Thus, this study helps in understanding the mitigation of harmonic power flow in unbalanced and polluted radial distribution system by using IEEE 13, 37 and 123 test bus system by using forward backward sweep load flow method. The test system which is designed for IEEE 13, IEEE 37 and IEEE 123 bus system is built in MATLAB in a format that is compliant with the Simulation. First, the test system is built with feeder IEEE 13 with general data which is shown in next chapter in detail secondly the test system is built with the general data which is shown in next chapter and lastly the test system is built with the general data which is also shown in next chapter and graph is plotted between total harmonic distortion versus nodes later.

#### 5. RESULTS & DISCUSSION

This result gives the mitigation of harmonic power flow in unbalanced and polluted radial distribution system by using IEEE 13, 37 and 123 test bus system which is modelled in MATLAB by using Simulink. The various feeders are modelled by using different IEEE test bus to show relevant results for the system. The system was tested under several different operating conditions.

Table. 5.1 Classification of Buses

Bus Type	Quantities Specified	Quantities to be Obtained
Load Bus	P, Q	$ V , \delta$
Generator Bus	P, $ V $	Q, $\delta$
Slack Bus	$ V , \delta$	P, Q

The IEEE 13, 37 and 123 test bus system is well known as test bus system. It is a P-Q or Load bus, P- $|V|$  or generator bus and  $|V|$ - $\delta$  or slack bus whose quantities are shown in table 5.1 and value is shown below in the form of general data table 5.2.

Table. 5.2 General Data of Buses

General Data	13 Bus	37 Bus	123 Bus
Slack	632	701	149
V nom(kV)	4.1600	4.8000	4.1600
V slack phase a	1.0210	1.0283	1.0100
V slack phase b	1.0420	1.0249	1.0100
V slack phase c	1.0174	1.0112	1.0100
Ang slack phase a	-2.49	-29.5322	0
Ang slack phase b	-121.72	-150.5195	-120
Ang slack phase c	117.83	90.1923	120

This method computes the power flow solution for its given radial network with its loadings and to verify the effectiveness of the implemented algorithms, simulation tests are carried out on IEEE test feeders for distribution systems (13, 37, 123 buses). To accuracy test, results of implemented modelling in fundamental frequency are compared to results of IEEE test feeders which are insignificant and negligible which shows the high accuracy of implemented algorithm.

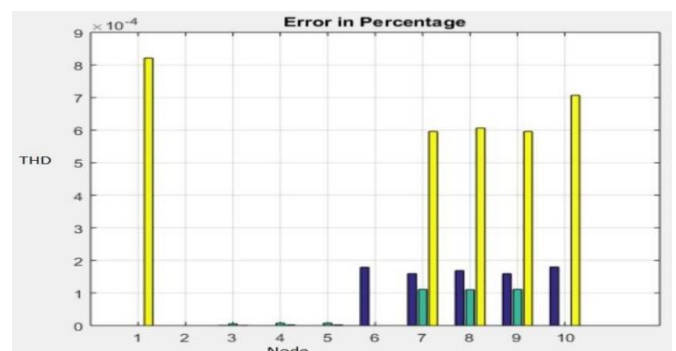

Figure 5. 1 RESULTS OF THD FOR IEEE 13 TEST BUS

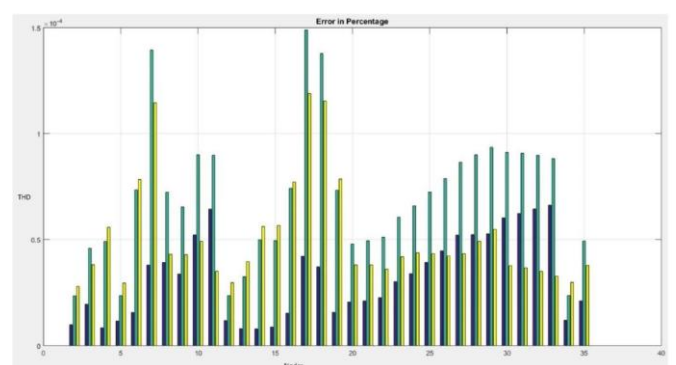

Figure 5. 2 RESULTS OF THD FOR IEEE 37 TEST BUS

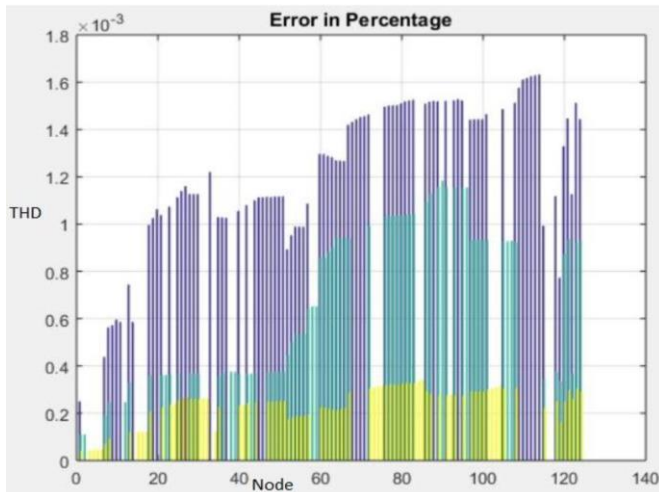

Figure 5. 3 RESULTS OF THD FOR IEEE 123 TEST BUS

## 6. CONCLUSION

In this report, a direct method for distribution load flow solution is presented to solve load flow problem by using two matrices, BIBC and BCBV. BIBC is abbreviated form of bus injection to branch currents, and the BCBV stands for branch currents to bus voltages. These two matrices are collectively used to form a direct approach to solve the load flow problems in case of balanced distribution system. For unbalanced distribution system backward sweep is used for calculation of branch current and forward sweep is used for bus voltage. The simulation tests are carried out on IEEE test feeders for distribution systems (13, 37, 123 buses).

## 7. FUTURE SCOPE

The future extent of the exploration work revealed in the paper of the executed plan can be additionally contemplated under substantial unsettling influences for improving the voltage security and the dynamic and transient conduct of the framework can be researched facilitate with a specific end goal to foresee the voltage solidness. The application can likewise be checked by utilizing diverse test transport framework for future work.

## REFERENCES

- [1] Bitar Arabsalmanabadi, Alireza Javadi and Kamal Al-Haddad, "Harmonic Power Flow in Unbalanced and Polluted Radial Distribution Systems" IEEE International Conference on Industrial Technology (ICIT) May 2017.
- [2] Bo Chen, Chen Chen, Jianhui Wang and Karen L. Butler-Purry, "Sequential Service Restoration for Unbalanced Distribution Systems and Microgrids" IEEE Transactions on Power System July 2017.
- [3] Hamed Ahmadi, José R. Mart and Alexandra von Meier, "A Linear Power Flow Formulation for Three-Phase Distribution Systems" IEEE Transactions on Power Systems Vol 31 Issue 6 February 2016.

- [4] Guangzheng Yu and Tao Lin, "2m+1 Point Estimate Method for Probabilistic Harmonic Power Flow" IEEE Power and Energy Society General Meeting (PESGM) November 2016.
- [5] Alireza Javadi, Student Member, IEEE, Abdelhamid Hamadi, Auguste Ndtoungou, and Kamal Al-Haddad, "Power Quality Enhancement of Smart Households using a Multilevel-THSeAF with a PR Controller" IEEE Transactions on Smart Grid September 2016.
- [6] Abner Suchite Remolino, Hector Francisco Ruiz Paredes, "An efficient method for power flow calculation applied to the reconfiguration of radial distribution systems" IEEE PES Transmission & Distribution Conference and Exposition - Latin America (PES T&D-LA). Morelia, Mexico November 2016.
- [7] Alireza Javadi, Student Member, IEEE, and Kamal Al-Haddad, "A Single-Phase Active Device for Power Quality Improvement of Electrified Transportation" IEEE Transactions on Industrial Electronics May 2015.
- [8] Ritam Misra and Sumit Paudyal, "Analysis and Reduction of Total Harmonic Distortions in Distribution System with Electric Vehicles and Wind Generators" IEEE Power & Energy Society General Meeting July 2015.
- [9] Shan Liu, Bo Chen, Takis Zourntos, Deepa Kundur, and Karen Butler-Purry, "A Coordinated Multi-Switch Attack for Cascading Failures in Smart Grid" IEEE Transactions on Smart Grid, VOL. 5, NO. 3, MAY 2014.
- [10] Chad Abbey, David Cornforth, Nikos Hatziaargyriou, Keiichi Hirose, Alexix Kwasinski, Elias Kyriakides, Glenn Platt Lorenzo Reyes and Siddharth Suryanarayanan, "Microgrid Operation for more Efficient Disaster Recovery" IEEE Power Through the Strom and Energy Magazine, April 2014.
- [11] Hamed Ahmadi, Abdullah Alsubaie and Jose R. Marti, "Distribution System Restoration Considering Critical Infrastructures Interdependencies" IEEE PES General Meeting Conference & Exposition, July 2014.
- [12] Yong Li, Tapan Kumar Saha, Olav Krause, Yijia Cao and Christian Rehtanz, "An Inductively Active Filtering Method for Power Quality Improvement of Distribution Networks with Nonlinear Loads" IEEE Transactions on Power Delivery, Vol 28, No. 4, October 2013.
- [13] Bo Chen, Salman Mashayekh, Karen L. Butler Purry and Deepa Kundur, "Impact of Cyber Attacks on Transient Stability of Smart Grids with Voltage Support Devices" IEEE Power & Energy Society General Meeting, July 2013.



- [14] M. Shareghi, B.T. Phung, M.S. Naderi and T.R. Blackburn and E. Ambikairajah, "Effects of Current and Voltage Harmonics on Distribution Transformer Losses" IEEE International Conference on Condition Monitoring and Diagnostics, September 2012.
- [15] H. Ahmadi and H. Ghasemi, "Probabilistic optimal power flow incorporating wind power using point estimate methods," in Proc. IEEEIC, May 2011
- [16] M. Z. Kamh and R. Iravani, "Unbalanced model and power-flow analysis of microgrids and active distribution systems," IEEE Trans. Power Del., vol. 25, no. 4, pp. 2851–2858, Oct. 2010.
- [17] M. Dilek, F. De León, R. Broadwater, and S. Lee, "A robust multiphase power flow for general distribution networks," IEEE Trans. Power Syst., vol. 25, no. 2, pp. 760–768, May 2010.
- [18] T.-H. Chen and N.-C. Yang, "Loop frame of reference based three phase power flow for unbalanced radial distribution systems," Elect. Power Syst. Res., vol. 80, no. 7, pp. 799–806, 2010.
- [19] R. F. Arritt and R. C. Dugan, "The IEEE 8500-node test feeder," in Proc. IEEE PES T&D Conf. Expo., 2010.
- [20] R. Singh, B. C. Pal, and R. B. Vinter, "Measurement placement in distribution system state estimation," IEEE Trans. Power Syst., vol. 24, no. 2, pp. 668–675, May 2009.
- [21] S. Rahmani, K. Al-Haddad, and H. Kanaan, "A comparative study of shunt hybrid and shunt active power filters for single-phase applications: Simulation and experimental validation," Journal of Mathematics and Computers in Simulation (IMACS), Elsevier, vol. 71, pp. 345-359, June 19 2006.