

Development of an Adjustable Cone Flow Meter and Its Experimental Analysis

Prabhuraj C U¹, Alvin Johny², Avinash B³, Vishnu A⁴, Vyshak T S⁵

¹Asst Professor, Dept. of Mechanical Engineering, Ammini College of Engineering, Palakkad-678613

^{2,3,4,5}B.Tech Scholars, Dept. of Mechanical Engineering, Ammini College of Engineering, Palakkad-678613

Abstract - A cone flow meter is a device which is used to measure flow rate of fluids like water, air, slurry, wet gas, etc. it is generally a differential pressure meter that measures the pressure drop across the upstream and downstream sections of an obstruction and use it to calculate the discharge. The cone flow meter consists of a cone that is held at the centre of the pipe that creates the pressure drop. The pressure readings are taken between a tapping at the upstream section and at the vena contracta by means of a hole drilled along the length of the cone.

Generally all differential pressure meters have the coefficient of discharge value more fluctuating at low discharges, and the pressure drop is small to be accurately measured. To increase the pressure drop at low discharges the beta ratio has to be decreased. We aim to develop and design a cone flow meter with an adjustable beta ratio for measuring low values of discharges by creating a larger pressure drop. A conceptual mechanism for the adjustable beta ratio is given. A comparison between the adjustable and the traditional solid cone flow meter is also made.

Key Words: Beta ratio, vena contracta, boundary layer formation, velocity profile, calibration curve, pressure angle, etc...

1. INTRODUCTION

Differential-pressure meters work on the principle of partially obstructing the flow in a pipe. This creates a difference in the static pressure between the upstream and downstream side of the device. This difference in the static pressure (referred to as the differential pressure) is measured and used to determine the flow rate.

Differential-pressure meters are hugely popular and it is estimated that at least 40% of industrial flow meters in use at present are differential-pressure devices, with the orifice plate being the most popular. Differential-pressure devices have been used to meter a wide variety of different fluids from gases to highly viscous liquids.

The V-Cone throttle device has been paid more and more attentions on the measurement of the wet gas flow in recent years. V-Cone flow meter has various advantages over conventional flow meter. The V-Cone Meter provides flow measurement with an accuracy of up to $\pm 0.05\%$ over a turn down ratio of 30:1. The pressure difference of front and back of the cone is used to realize flow speed measurement. V-Cone Meter expands the flow measurement scope and avoids some limitations of traditional difference flow meter.

Velocity depends on the pressure differential that is forcing the fluid through a pipe. Because the pipe's cross-sectional area is known and remains constant, the average velocity is an indication of the flow rate. Other factors that affect liquid flow rate include the liquid's viscosity and density, and the friction of the liquid in contact with the pipe. Measurement of the flow of a fluid, either liquid or gas, is commonly a critical parameter in many processes. In most operations this can be linked to the basic need of the process, knowing that the right fluid is at the right place and the right time. Equally, it can be linked to asset management, keeping the fluid in motion or even simple tank balancing. Some applications, however, require the ability to conduct accurate flow measurements to such an extent that they influence product quality, health and safety, and ultimately can make the difference between making a profit and running at a loss.

2. CONE FLOW METER

Cone meters have proved popular as it is claimed they require very little upstream straight pipe work before the meter to provide accurate measurements. This benefit is due to the fluid flowing around the cone which is described as "conditioning" the flow. One of the downsides of cone meters is the lack of standards governing this type of meter, as they have been a proprietary device, and there has been a lack of independent data available to provide confidence in claimed performance. Unlike venturi tubes, orifice plates and nozzles, which are manufactured to tolerances specified in ISO 5167, cone meters are not manufactured to a specified tolerance and must be individually calibrated before use.



Fig 2.1 cone flow meter

2.1 Beta Ratio

All DP meters work according to the principles of the conservation of mass and energy. In V-Cone Meter, water is flowing along wall of pipe (peripheral side) and in orifice

meter, water is flowing from center part of pipe (As shown in Fig 2.2).

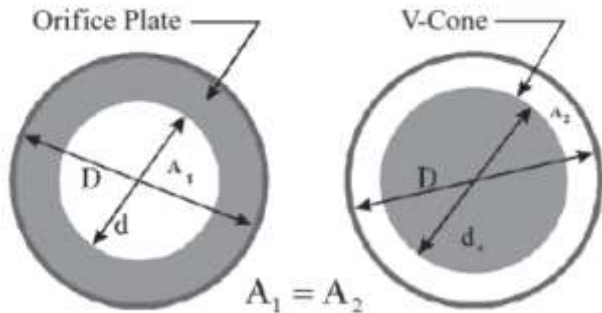

Fig 2.2 Schematic Diagram of Orifice Plate and V-cone meter

$$\beta_{\text{orifice/venturi}} = \sqrt{\frac{A_d}{A}} = \frac{d}{D} \quad \dots \text{eq(A)}$$

$$\beta_{\text{v-cone}} = \sqrt{\frac{A_d}{A}} = \sqrt{1 - \frac{d^2}{D^2}} \quad \dots \text{eq(B)}$$

2.2 Discharge Coefficient (Cd)

The discharge coefficient, C, is a parameter that takes account of non-ideal effects, for example energy losses due to friction, when using ΔP meters. The discharge coefficient is basically the ratio of the actual to the measured mass flow rate.

2.3 Mass Flow Rate in a Cone Flow Meter

The actual mass flow rate is,

$$m = \frac{C_d A_2}{\sqrt{1 - \beta^4}} \sqrt{2 \Delta P \rho}$$

C_d is the coefficient of discharge
 A is the throat area (restriction)
 ΔP is the differential pressure
 ρ is the density of the fluid

2.4 Variation of Pressure Drop with Beta Ratio

As change in beta ratio, we get drastic change in differential pressure value.

As beta ratio increase, differential pressure value decrease.

More DP gives less least count, which gives more accuracy. Small change in flow gives max deflection in DP.

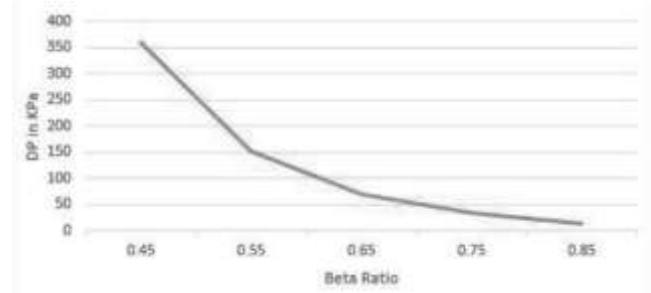

Fig 2.3 Effect of changing beta ratio on ΔP

$$\beta \propto \frac{1}{\Delta P}$$

This drastic change in pressure drop is beneficial, especially at low values of discharges. For low beta ratios (< 0.55), the pressure drop is very high and the discharge can be measured even with a low resolution device, like a U-tube manometer.

From fig 2.3 it is clear that at low values of discharge the pressure drop is very low and their measurement is difficult. Hence, lower beta ratios are required to measure such discharges. But at higher discharges the large diameter cone produces large restriction towards flow so for very high discharges higher beta ratio is preferred. These conditions limit the usage of the same cone flow meter for wide range of operating discharges. The possible solution is to manufacture an adjustable cone flow meter with a beta ratio that can be varied as per the discharge conditions.

3. EXPERIMENTAL STUDY OF CONE FLOW METER

Traditional cone flow meters are solid meters with fixed beta ratios and size. Also for every differential pressure meters the measurable range of flow is within a fixed range of fluid discharge. Their ability to measure at low discharges accurately is very low.

The pressure drop is inversely proportional to the beta ratio. To state that a ΔP meter has a low beta ratio, for example $\beta = 0.2$, means the plate has a small hole or restriction size. This causes the pressure loss across the ΔP meter to be higher, which may mean that a pump with a higher discharge pressure (hence more expensive) or compressor will be needed to overcome the increased pressure loss and maintain a flow rate achievable with a larger beta ΔP meter. On the other hand a higher differential pressure can generally be measured more accurately than a lower one. Hence lower the beta ratio, greater is the accuracy of measurement.

The aim of the project is to develop, design and manufacture an adjustable type cone flow meter whose beta ratio can be adjusted so as to result in a lower beta ratio at low discharges to create larger pressure drop. This large pressure drop can be easily measured. The plan of action of the project is given below.

A solid cone flow meter has to be designed and analyzed to study the effect of low beta ratio at low values of discharges. The expected result is a C_d vs discharge plot that

fluctuates at low discharges and has a lower coefficient of discharge at such ranges. The next step is to design an adjustable cone flow meter that can vary its beta ratio. The challenge involves devising a mechanism to achieve the required expansion, and it has to be simple and reliable during actual operating conditions.

3.1 Design of Solid Cone Flow Meter

The solid cone flow meter has a standard design specified in many journals. McCrometer, inc, California, have done large number of researches in the field of cone flow meter. Thus, here the design that is specified by McCrometer is being used.

The diameter of the pipe is selected as 2.5" (60mm). This is in accordance with the discharge available from the 0.5 hp pump in the college fluids lab. The beta ratio is selected as 0.85 (typical range of beta is from 0.4 to 0.85). From the diameter of the pipe and the beta ratio, the diameter of the cone can be determined using equation (B).

The cone flow meter consists of the cone body and the attaching stem. For the experiment cone body is made of mild steel and is manufactured by using a common lathe. The cone diameter is rounded off to the next whole number. The cone angles in the upstream and the downstream sections are 45° and 135° respectively. The edge angle of the cone can be calculated as 90°. The cone is attached to the pipe by using the attachment stem. The diameter of the stem is one tenth of the pipe diameter.

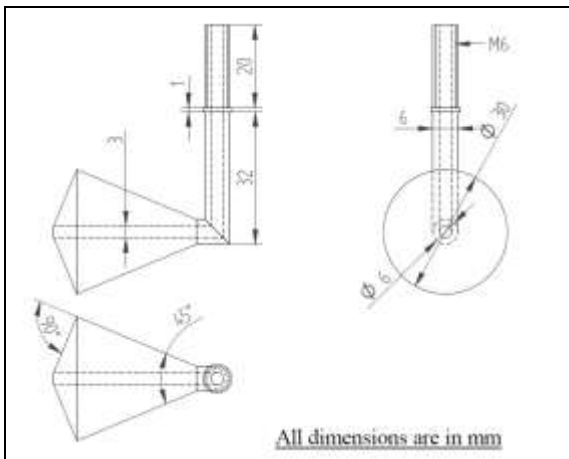

Fig 3.1 Important Dimensions of V-Cone Meter

3.2 Cone Flow Meter Assembly

The cone flow meter control volume is the space consisting of the cone flow meter, the pipe with the reference diameter, the pressure tapping, and the reducers and the connectors to link to the water line. The control valve is placed at the end of the downstream region. This ensures that the control volume is always filled with water and no air entrapment occurs.

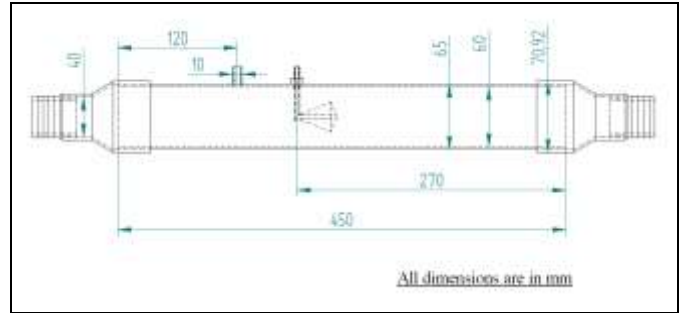

Fig.3.2 Important dimensions of cone flow meter assembly

Table 3.1 List of materials used

Sl.no	Component name	Material	Size	Quantity
1	Pipe	PVC	2.5"	1m
2	Pipe	PVC	1.5"	0.5m
3	Ball valve	PVC	1.5"	2 nos
4	Reducer	PVC	2.5*1.5	2 nos
5	Coupling	PVC	2.5"	2 nos
6	Coupling	PVC	1.5"	2 nos
7	Ball valve	Brass	3/4"	1 no
8	Push-in male connector	Brass	1/4"	1 no
9	Hose connector	Steel	1"	2 nos
10	Thread seal tape	PTFE	12mm*0.075mm	As required
11	Washer	Steel	1mm	2 nos
12	Packing	Asbestos	-	As required
13	Sealant	Epoxy adhesive	-	As required

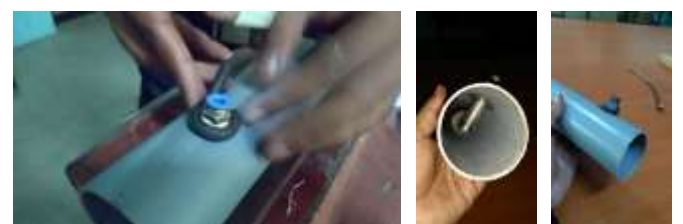
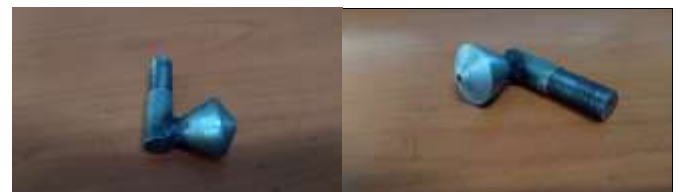



Fig 3.3 Experimental test apparatus assembly

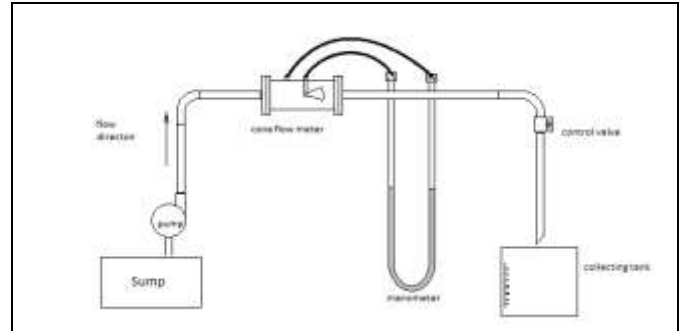

Fig 3.4 experimental test rig

3.3 Experimental Test Rig

The experimental test setup consists of an arrangement to provide controlled flow of water through cone flow meter apparatus. The flow is provided using a centrifugal pump of 0.5 hp capacity. The discharge is controlled using two ball valve placed in the upstream and downstream sections. The pressure drop across the cone flow meter is determined using a mercury manometer. This is then used to find the theoretical discharge through the pipe. The actual discharge is determined by using a collection tank and a stop watch.

The calibration of the cone flow meter is done using the following steps:

1. Initially check for any loose fitting of the connections, such as the thread seal tape connection, manometer connections, etc.
2. Ensure that there is no air entrapped inside the manometer tubes, otherwise there will be errors in the readings taken.
3. Close all the valves of the test apparatus and turn on the pump motor switch.
4. Now gradually open the control valve till there is maximum flow through the pipe.
5. For maximum discharge there occurs maximum deflection in the manometer.
6. Now close the control valve in steps and note the manometer reading corresponding to each step.
7. Close the control valve completely and turn off the pump.
8. Determine the table values using the readings and plot the calibration curve.

3.4 Observations and Results

Table 3.2 Calculation of coefficient of discharge

H1	H2	ΔH	Δh	h in meters of water	TIME (t)	Qa	Qa	Qt	Cd
cm	cm	cm	m		s	m ³ /s	m ³ /h	m ³ /s	
69	68.1000	0.8067	0.008067	0.101645	5	0.004	14.4	0.00476	0.8397
68.8	68.4000	0.4106	0.004106	0.051740	7.11056	0.002812718	10.1258	0.0034	0.8276
68.77	68.6230	0.1470	0.001470	0.018524	12.001	0.001666528	5.99950132	0.00203	0.8195
68.72	68.6972	0.0228	0.000228	0.002879	30.6049	0.00065349	2.35256573	0.0008	0.8151
68.69	68.6847	0.0053	0.000053	0.000667	63.984	0.000312578	1.12528076	0.00039	0.8101
68.63	68.6273	0.0027	0.000027	0.000346	89.3806	0.00023762	0.80554407	0.00028	0.8046
68.59	68.5884	0.0016	0.000016	0.000205	117.528	0.000170172	0.61261879	0.00021	0.7945

1. Head difference,

$$\Delta H = H1 - H2$$

2. h in meters of water,

$$h = 12.6 * \Delta H(\text{in m}), \quad [\text{for mercury manometer}]$$

3. Actual discharge,

$$Q_a = A * \frac{0.05}{t}$$

Where, A= area of collection tank = 0.2 sq m

t= time taken for 5cm rise in water level

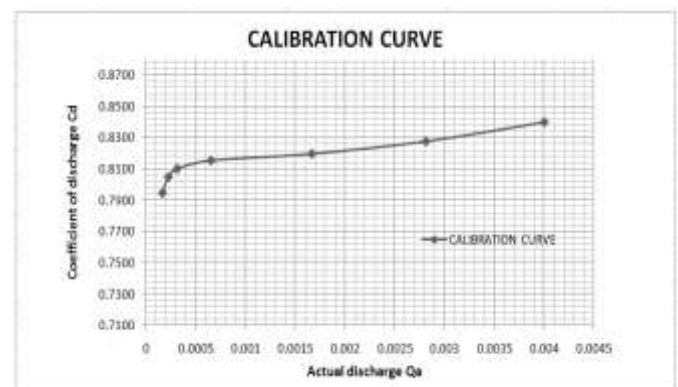

Fig 3.5 Calibration Curve

The calibration curve shows that there is significant fluctuation in the coefficient of discharge at low values of actual discharges which is below $0.001 \text{ m}^3/\text{s}$. At these discharge ranges the coefficient of discharge varies within 0.79 and 0.82. Apart from the low discharges the Cd value is fairly constant throughout all other values of increased flow rates, i.e., between the discharge values of 0.001 and $0.004 \text{ m}^3/\text{s}$. The maximum value of Cd for experiment is 0.83.

We can see from the table that the pressure drops at low discharges is very low (0.0016 to 0.0053 m of water). This is very difficult to be measured using measuring devices with low accuracy, like a mercury manometer. Here the readings were taken using digital pressure meters having an accuracy of 10^{-4} m of water.

It is to be noted that the range of coefficient of discharge obtained is high for a flow measuring device. Orifices and venturies have their Cd values in the order of 0.6 to 0.8. This shows the reliability of the cone flow meter to give considerably accurate values of discharge measurements. This is due to the properties of cone flow meter like, velocity profile reshaping, pressure tapping at the center of the pipe at not at the periphery, low turbulent losses, etc. The performance of a cone flow meter at low discharges is of concern in the project.

4. ADJUSTABLE CONE FLOW METER

The observations from the calibration of the solid cone flow meter showed that the pressure drop at low discharges is very low and hence difficult to be measured using conventional measuring devices. The usage of high precision pressure measuring devices takes its own costs which is high. So we need to increase the pressure drop at low values of discharges in order to accurately measure the pressure drop using a manometer. Increasing the pressure drop involves increasing the constricted area of flow. Annular area around the cone flow meter has to be decreased for doing this. Or in other words decrease the beta ratio of the cone flow meter. The beta ratio should vary from small at low flow rates and to high at large discharges. Hence a cone flow meter with adjustable beta ratio has to be designed to achieve this, which is the objective of the project.

The main challenge of the project is to devise a mechanism to get the adjusting motion in the cone flow meter. The cone flow meter is situated inside the pipe and the adjusting mechanism has to be incorporated into it and operated from outside. The operation is manual and requires calibration to know the position of the cone flow meter (beta ratio), to adjust it based on whether there is low or high discharges.

4.1 Proposed Design of Adjustable Cone Flow Meter

The conceptual design of the adjustable cone flow meter is shown in the sketch below.

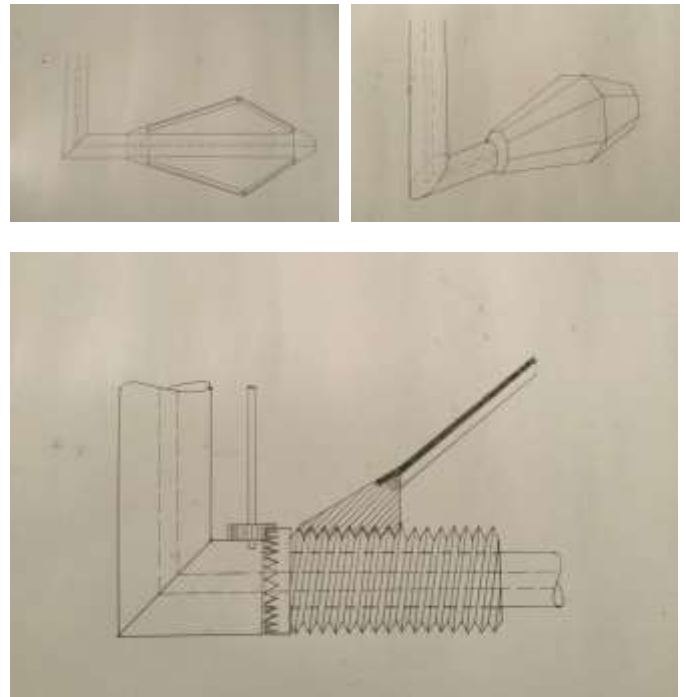

Fig. 4ss.1 Design of Adjustable cone flow meter

A conceptual design of the cone flow meter is shown in the sketch. The overall arrangement of the adjustable cone flow meter and its assembly in the pipe fixture is similar to that of the solid cone flow meter. The solid conical body in the solid cone flow meter is replaced by the adjustable mechanism. The supporting stem remains the same both in length and size. The entire system is held firmly in the pipe using the stem threads and the nut. Asbestos layer is provided to give a leak free seal.

The adjustable cone flow meter consists of the following main parts. The cone flow meter shaft is the part that holds and supports the entire setup in its position during strong pressures and discharges. It is made of stainless steel which has high stiffness and strength. The fixed cone is fixed on the cone shaft at the downstream end where the pressure tapping is done. The movable cone rests on the threads of the bevel actuator and is not fixed to the cone shaft. It is made of brass for having considerable strength and less coefficient of friction while it moves along the threads. The most important parts of the adjustable cone flow meter are the adjusting gear and the bevel actuator. The parts are joined by a bevel gear to get a 90° intersecting axes. The bevel gear has a pressure angle of 20° and module of 3mm. The adjuster gear is rotated manually from outside the pipe using a hand screw for smaller sizes of the adjustable cone flow meter, and a spanner for larger sizes of it. When the adjuster is rotated, the bevel actuator rotates with it. The actuator is held in its position itself without transverse movement. This is achieved using a retaining pin. The axial rotation of the movable cone is prevented by the fixed cone. Under this restriction the movable cone moves only in the axial direction without rotation. There are several metal

strips to enclose the adjusting mechanism and to give the conical shape and operational characters of the cone flow meter. The metal strips are made of stainless steels having a thickness sufficient to withstand the pressure forces. The upstream metal strips are longer compared to the downstream metal strips. The shape of the metal strips is trapezoidal. The connections between the upstream and downstream metal strips and that between the strips and the fixed the movable cones are made by pins. The mechanism is covered by a rubber sheet that has the same outer shape of the cone flow meter. This is then attached to the fixed and movable coned by using glue.

5.2 Working

The general position of the adjustable cone flow meter is having a beta ratio of 0.6, which is the minimum value of it. Under large discharges this is sufficient to create good pressure drops to be measured accurately. When the flow rate decreases, the pressure drop is small and the mercury manometer shows only a small deflection, which cannot be measured accurately. Thus at this point of measurement, the adjustable mechanism can be utilized.

The small pressure drops can be increased by rotating the adjuster in the clockwise direction. This moves the movable cone towards the fixed cone. This in turn moves the metal strip in the upward direction, thus increasing the diameter of the cone. This causes an increased constriction to the flow, or we can say that the beta ratio is decreased. When the beta ratio is decreased the pressure drop increases and can be more accurately measured with the mercury manometer itself. During low values of discharge rates, the adjuster is rotated in the counter clockwise direction to increase the beta ratio and decrease the diameter of the cone. The degree of rotation and the beta ratio achieved is assigned by calibration. For this both the extreme positions of the adjuster is set and the corresponding beta ratio is found out using a screw gauge. Then the diameter for unit degree rotation is found out in steps. Finally a calibrated chart is made to control the rotation manually. The calibrated chart consists of a reducer gear and a dial. The dial indicates the beta ratio for each rotation. From the calibration it can be seen that the beta ratio is not a linear function of the degree of rotation.

The procedure for the operation of the adjustable cone flow meter is that, when the manometer reading is very small, rotate the adjuster gradually until the reading increases. The discharge is not varied but only the beta ratio is adjusted. This new value of the manometer reading at the beta ratio reading from the dial is to be noted down. The discharge can be found out by substituting the values in the equation relating the beta ratio, pressure drop and the discharge. It must be kept in mind that the beta ratio is not constant here and varies for every rotation of the adjuster screw. The maximum value of beta achievable is limited to 0.85, since this is the prescribed maximum limit of beta ratio as described in journal [1].

6. CONCLUSIONS

The calibration curve obtained from the experimental study of the solid cone flow meter shows that the curve is in close resemblance with the expected results in [1]. It shows that the coefficient of discharge is very fluctuating at low values of discharges and from the table values of discharge and pressure it is clear that the pressure drop at low discharges is very low and its measurement with a mercury manometer is very difficult. But for larger discharges, the coefficient of discharge is constant and is reliable.

A variable beta ratio overcomes the difficulty of measuring very small discharges by decreasing the beta ratio. The adjustable mechanism developed can vary the beta ratio as required by the operator. It is expected to give the required pressure drop at low values of discharges. As far as the mechanism is concerned, it is simple in construction, easy to operate.

REFERENCES

- [1] IOSR Journal of Mechanical & Civil Engineering (IOSRJMCE) e-ISSN: 2278-1684,p-ISSN: 2320-334X PP 32-36 www.iosrjournals.org
- [2] IOSR Journal of Mechanical and Civil Engineering (IOSR-JMCE) e-ISSN: 2278-1684,p-ISSN: 2320-334X PP. 22-28
- [3] IOSR Journal of Mechanical & Civil Engineering (IOSRJMCE) e-ISSN: 2278-1684,p-ISSN: 2320-334X PP 32-36
- [4] Fluid Control Research Institute, Kanjikode Palakkad
- [5] www.mccrometer.com