

# Design and Fabrication of Bi-Axial Rotational Moulding Machine

Ankush Kataria<sup>1</sup>, Saurabh Singh Gusain<sup>2</sup>, Suraj Dadge<sup>3</sup>, Vikrant Singh<sup>4</sup>, Dr. Nilesh R. Kharche<sup>5</sup>

<sup>1,2,3,4</sup> UG Students of Mechanical Department, Dr. DY Patil School of Engineering and Technology, Lohegaon via Charoli, Pune, India-412105

<sup>5</sup>Assistant Professor, Dept. of Mechanical Engineering, Dr. DY Patil SOET, Pune, Maharashtra, India

\*\*\*

**Abstract** - Rotational moulding is becoming a highly sophisticated manufacturing method for plastic parts. New mould and machine features, and advanced process control technologies are becoming available at regular intervals. This gives designers, and end users, access to new opportunities to create innovative plastic mouldings.

The ever-changing nature of this industry means that it is very important for those involved in the manufacturing a characteristic feature of those in the rotational moulding industry is that there has always been a strong desire to utilise new technology and to be innovative in the use of new information. Throughout the world it has been evident that in this industrial sector there is a hunger for new information and a willingness to try new things.

**Key Words:** Roto-moulding, Mould Charging, Mould Heating, Mould cooling, Part Ejection, Quick Setting Polymers, Conceptual and practical design

## 1. INTRODUCTION

Rotational moulding, also known as roto casting or roto moulding, is a low pressure, high temperature manufacturing method for producing hollow, one-piece plastic parts. As with most manufacturing methods for plastic parts, rotational molding evolved from other technologies. The basic principle of forming a coating on the inside surface of a rotating mould dates back for many centuries, but the process did not gain recognition as a moulding method for plastics until the 1940s.

The basic principle of rotational moulding involves heating powdered (or liquid) plastic, and subsequently cooling it, inside a hollow shell-like mold. During the heating stage, the mould is rotated so that the melted plastic forms a coating on the inside surface of the mold. The rotating mould is then cooled so that the plastic solidifies to the desired shape and the molded part is removed. There are many methods that can be used to achieve the three essential requirements of the process – that is, (a) charging (b) mould rotation and (c) heating and (d) cooling. Early types of rotational moulding machine involved the heating of the rotating mould by an open flame. The mould rotation usually involved a ‘rock and roll’ motion. This description was used because the mould rotated through 360o about one axis and was rocked backwards and forwards about the other axis. Few modern commercial rotational molding machines involve direct flame heating of the mould but the rock and roll rotation mechanism is still used in some cases.

Most modern rotational mould machines involve full biaxial rotation about two perpendicular axes and use a hot air oven to heat the rotating metal mould. Other mould heating methods that are less common include electrical elements on the mould, infrared or microwave heating, or hot oil circulated in a jacket around the mould.

We are replacing LLDPE material with quick setting polymer like POP. By doing so we do not require any heating or cooling process.



Fig -1: Bi-axial Rotational Moulding Machine

## 2. MANUFACTURING OF ROTOMOULDING

### Bill of Material

#### (A) Fork Sub Assembly

Table -1: Bill of material of Fork Sub-Assembly

S. N.	DESCRIPTI ON	MATERIA L	RM-01-000-00
1	Fork	Mild steel	RM-01-001-00
2	Mould	Mild steel	RM-01-002-00
3	Mould Clamp - I	Mild steel	RM-01-003-00
4	Mould Clamp - II	Mild steel	RM-01-004-00
5	Slider	Mild steel	RM-01-005-00

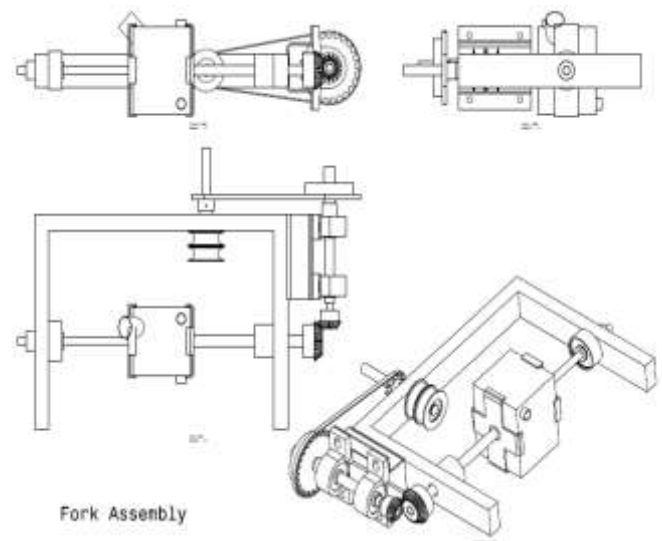
	Bearing Holder		
6	Slider Bearing	Standard	RM-01-006-00
7	Slider bush	Mild steel	RM-01-007-00
8	Fixed Bearing Holder	Mild steel	RM-01-008-00
9	Shaft - I	EN 9	RM-01-009-00
10	Shaft Bearing 6205	Standard	RM-01-010-00
11	Shaft Bearing Holder	Mild steel	RM-01-011-00
12	Bevel Gear - I	Engg. Std.	RM-01-012-00
13	Bevel Gear - II	Engg. Std	RM-01-013-00
14	Shaft - II	EN 9	RM-01-014-00
15	Plummer Block Bearing	Cast Iron Std.	RM-01-015-00
16	Plummer Block Bracket	Mild Steel	RM-01-016-00
17	Sprocket - 25	Mild Steel	RM-01-017-00
18	Chain-1/2" pitch 54 Links	Spring Steel Std.	RM-01-018-00
19	Sprocket - 12 teeth 1/2" pitch	Mild steel	RM-01-019-00
20	Gear 1 (Planetary)	Polyamide	RM-01-020-00
21	Shaft - 3 (Planetary)	EN 9	RM-01-021-00
22	Planetary Bearing Holder	Mild steel	RM-01-022-00
23	Planetary Shaft Bearing 6203	Standard	RM-01-023-00

**(B) Drive Sub Assembly**

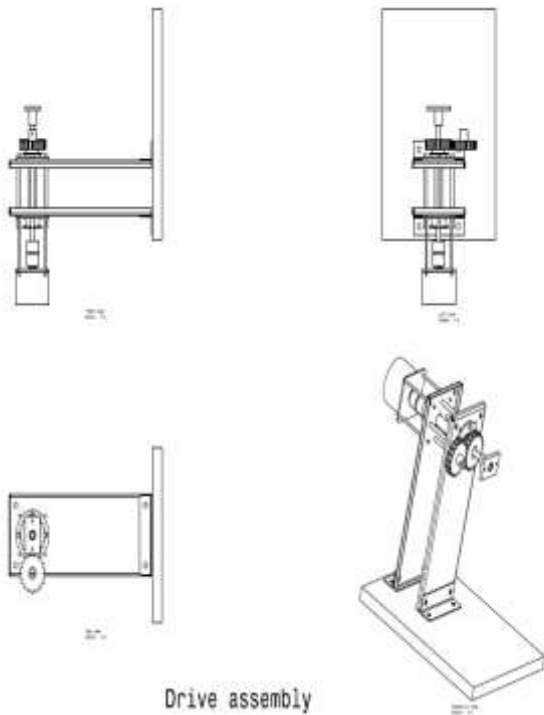
**Table -2:** Bill of material of Drive Sub-Assembly

S.N.	DESCRIPTI ON	MATERIA L	RM-02-000-00
1	Base Frame	Mild Steel	RM-02-001-00
2	Vertical Support	Mild Steel	RM-02-002-00
3	Main Shaft	EN 9	RM-02-003-00
4	Bearing Holder	Mild Steel	RM-02-004-00
5	Bearing (6203)	Standard	RM-02-005-00
6	Fixed Gear (D=86)	Polyamide	RM-02-006-00
7	Coupler	Aluminium	RM-02-007-00
8	Motor, 20kg-cm	Standard	RM-02-008-00
9	Fork Mounting Plate	Mild Steel	RM-02-009-00
10	Fork Mounting Bush	Mild Steel	RM-02-010-00

**3. Drawing of Roto Moulding Machine**

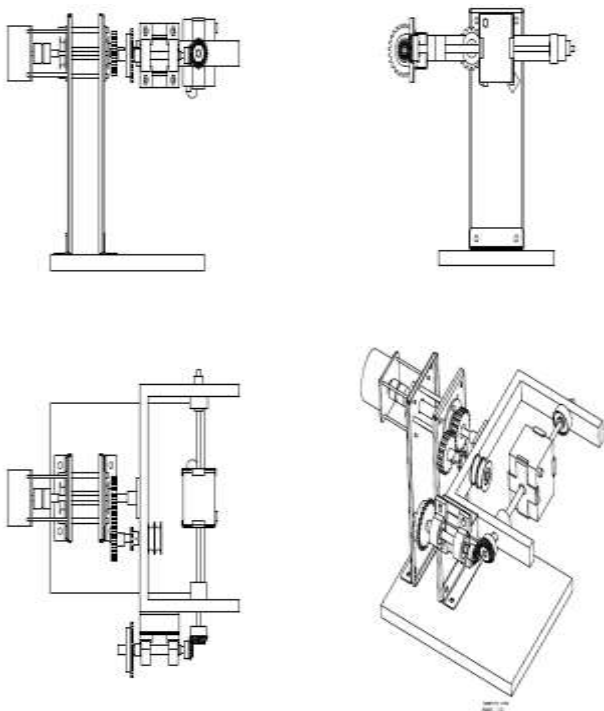


**Fig -2:** Fork Assembly



Drive assembly

Fig -3: Drive Assembly

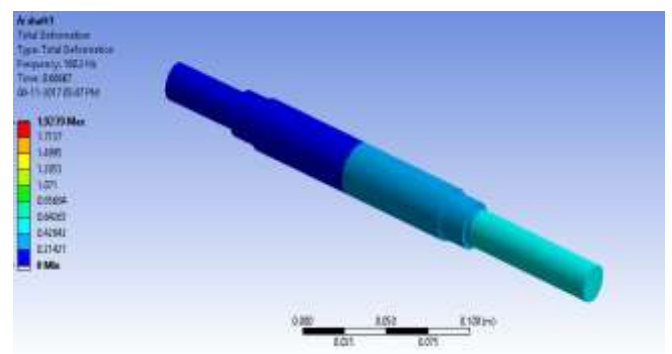
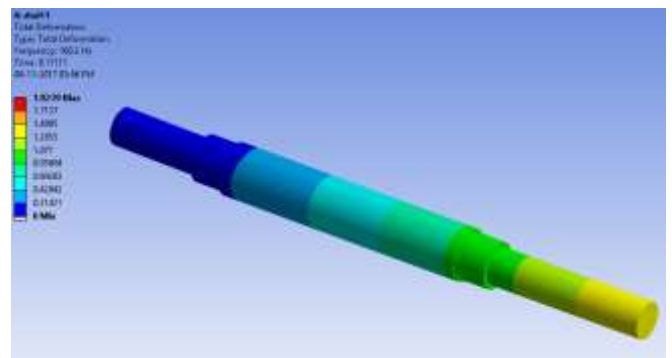


rotomoulding assembly

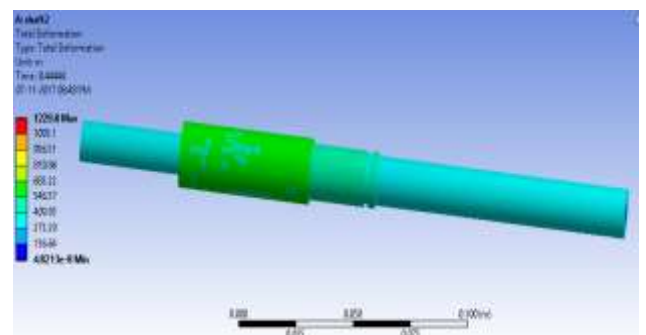
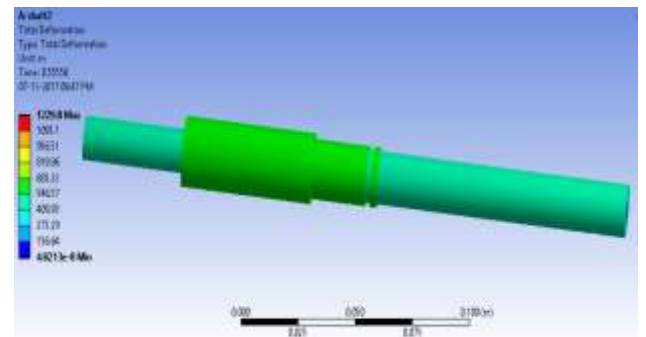
Fig -4: Bi-axial Rotational Moulding Assembly

### 3. Analysis for deflection using ANSYS

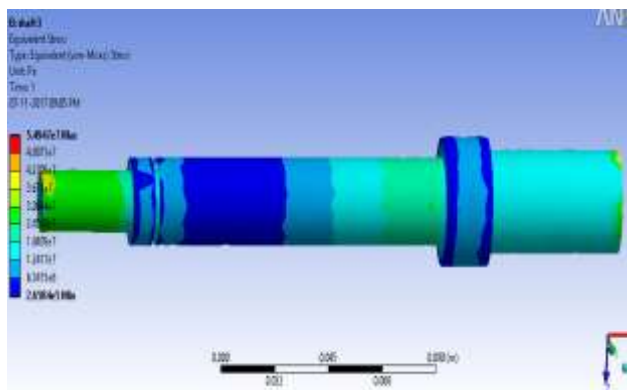
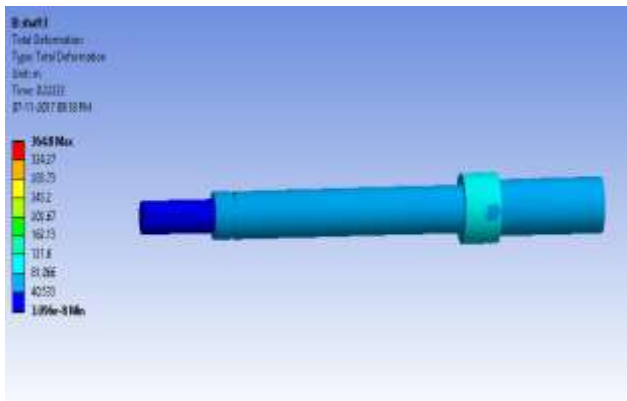
#### Shaft - 1



#### Shaft - 2



**Shaft – 3**



**5. CONCLUSIONS**

1. Rotomolded component has uniform thickness. Strength is improved then other moulding methods. It is easier construction, easier access to the mould for instrumentation is provided and better opportunity to feed material continuously as required to the rotating mould.

2. The component design is cubic in shape hence, after much research and deliberation, we came to conclusion that Linear low density polyethylene (LLDPE) would best possible material for the component because it has good flow behavior and displays excellent resistance to chemicals. But as it requires heating so we have replaced it with POP and remove Heater.

3. The decision to use Stainless Steel for die has been proved correct. The other option was aluminium. But stainless steel better thermal resistance, wear resistance. It saves cost and rework and can be used for longer periods. Hence Die Life is improved.

**Application**

Automotive-door armrest, instruments panel, Containers-planters, airline container, Toys and Leisure-balls, ride on toys, hobby horses, Marine Industry-dock floats, pool liners, docking fenders, Tanks-fuel tanks, shipping tanks, oil tanks

**REFERENCES**

[1]. R.J. Crawafor, Mark P. Kearns, “Practical Guide to Rotational Moulding”, 2003, Rapra Technology Limited

[2]. R.J. Crawafor, D.I. Abualdi, “Control of Rotational moulding using adaptive fuzzy system”, VOL. 24, NO. 4, 266–277 (2005)

[3]. Tomasz Jachowicz, Janusz W. Sikora, “Investigation of the influence of mould rotational speed on the cast wall thickness in the rotational moulding process”, Advances in Science and Technology Research Journal, Volume 7, No. 19, Sept. 2013, pp. 79–87

[4]. L Staineanu, A preliminary study on the rotational moulding process, Volume 7, Issue 1, 2012

[5]. Wai-On NG, Ching-Yuen CHAN, A computer simulation method for mould optimization of rotational moulded objects, International Conference on Machine Learning, Electrical and Mechanical Engineering (ICMLEME'20 14) Jan. 8-9, 2014 Dubai (UAE)