

BER IMPROVEMENT IN OFDM-IM USING TCM

Dhanveer Singh Meena¹, Prof. Sonu Lal²

^{1,2}IES College of Technology, Bhopal Kalkheda, Ratibad Main Road Bhopal-462044 M.P. India

Abstract: *Wireless communications have been emerged and quickly in the modern world particularly in the most recent decade. Ongoing advances in wireless communication systems have expanded the throughput over wireless channels. The dependability of wireless communication has additionally been expanded. Yet at the same time the data transmission and other requirements for better wireless services are increased. The need to accomplish accurate wireless systems with high proficiency, high quality and less error is the considerable matter. Orthogonal frequency division multiplexing (OFDM) with index modulation (IM) is a multicarrier transmission procedure for frequency specific fading channels. Since it is highly efficient, its execution may not be static as some dynamic subcarriers can be altered by fading. In this paper, we consider trellis coded modulation (TCM) for OFDM-IM so as to enhance the performance of dynamic subcarriers by expanding the Hamming distance between index sub carriers. We devise mapping rules for TCM for 1 x 2 encoder and it is demonstrated that the decent variety request can be enhanced, which brings about a lower likelihood of index error.*

Keywords: Trellis Coded Modulation, OFDM-IM, Bit Error Rate

1. Introduction

Presently, fourth generation (4G) mobile communication systems have turned out to be prominent all around the globe. However, its administrations can't give a major unique scope of information rates, nor would it be able to meet the pre-requisites of an assortment of business types. In addition, voice transportation in 3G still depends on circuit exchanging innovation, which is an indistinguishable strategy from utilized as a part of second-generation (2G) communication systems, as opposed to Internet Protocol (IP) approach. In this manner, on the basis of above points, numerous nations have just done research on the following totally developmental fifth generation (5G) communication systems which give a thorough and secure IP arrangement where voice, information, and multi-media can be offered to clients at "whenever, anyplace" with higher information rate as compared to previous generations. As transfer capacity resource in 4G wireless mobile communications is still rare, keeping in mind the end goal to enhance range proficiency and accomplish as high as 100Mbps wireless transmission rate, it requires further developed methods to be utilized. The modulation schemes limitations in existing communication systems has turned into a hindrance in additionally expanding the information rate. Subsequently, upcoming mobile communication systems require more complex modulation plan and data transmission structure.

Multiple input multiple output (MIMO) and Orthogonal frequency division multiplexing (OFDM) have along these lines been received because of its great performance. They guarantee to end up key rapid wireless communication innovations and joining them can give wireless industry development from 4G to 5G system.

2. Space Time Trellis Coded Modulation

Space-Time Trellis Codes (STTCs) were presented in 1998 [1] as a high-information rate, data transfer capacity and power-effective technique for communication over wireless Rayleigh and Rician fading channels. STTCs can accomplish an assorted variety advantage by setting the decent variety trouble on the base station, and henceforth leaving the versatile station to keep up its portability and reasonableness [1].

STTCs are completely in light of very much characterized trellis structures and henceforth they can be decoded utilizing delicate choice deciphering systems at the collector, for example, Viterbi interpreting. STTC modulation proposed a joint outline of coding, adjustment, and transmits assorted variety for level Rayleigh fading channels.

Trellis coded modulation (TCM) is a procedure that consolidates error rectifying coding and modulation in computerized communications [2]. TCM picks up commotion insusceptibility over un-coded transmission with no expansion in the flag transfer speed or the transmission control. By apportioning signal set into gatherings, TCM utilizes flag mapping to build the Euclidean separation, instead of the Hamming separation, between codes [3],[4]. TCM systems utilize $2m+1$ group of stars focuses for transmitting m bits. In [5], an orderly way to deal with parcel multidimensional signs is proposed. Since it generative mistake redress codes (ECCs, for example, turbo codes [6] and low-thickness equality check codes [7] are famous because of their close Shannon restrict unraveling execution, TCM has the upside of low disentangling inertness over these it generative codes. In this paper, an encoder and Viterbi decoder are executed to mimic the execution of room time trellis coded modulation in a second request assorted variety (two transmit and one get radio wires).

3. Orthogonal Frequency Division Multiplexing

Orthogonal frequency division multiplexing (OFDM) is a prevalent system for transmission of signs over wireless channels. OFDM has been embraced in a few wireless norms, for example, digital audio broadcasting

(DAB), digital video broadcasting (DVB-T), the IEEE 802.11a [8] local area network (LAN) standard and the IEEE 802.16a [9] metropolitan area network (MAN) standard. OFDM is likewise being sought after for DSRC for street side to vehicle interchanges and as a potential contender for fourth-generation (4G) versatile wireless systems. OFDM changes over a frequency specific channel into a parallel gathering of frequency level sub channels.

The subcarriers have the base frequency partition required to keep up symmetry of their comparing time area waveforms, yet the flag spectra relating to the diverse subcarriers cover in frequency. Consequently, the accessible transfer speed is utilized productively. On the off chance that information of the channel is accessible at the transmitter, at that point the OFDM transmitter can adjust its flagging methodology to coordinate the channel. Because of the way that OFDM utilizes an extensive gathering of barely separated subchannels, these versatile techniques can approach the perfect water pouring limit of a frequency particular channel. By and by this is accomplished by utilizing versatile piece stacking procedures, where diverse estimated flag groups of stars are transmitted on the subcarriers.

OFDM is a square modulation plan where a square of N data imgenerations is transmitted in parallel on N subcarriers. The time span of an OFDM imgeneration is N times bigger than that of a solitary carrier system.

An OFDM modulator can be actualized as a reverse discrete Fourier change (IDFT) on a square of N data imgenerations took after by a simple to-computerized converter (ADC). To alleviate the impacts of entomb imgeneration obstruction (ISI) caused by channel time spread, each square of N IDFT coefficients is ordinarily gone before by a cyclic prefix (CP) or a watch interim comprising of G tests, to such an extent that the length of the CP is at any rate equivalent to the channel length.

Under this condition, a straight convolution of the transmitted arrangement and the channel is changed over to a round convolution.

Therefore, the impacts of the ISI are effectively and totally wiped out. Additionally, the approach empowers the beneficiary to utilize quick flag preparing changes, for example, a quick Fourier change (FFT) for OFDM execution [10]. Comparable methods can be utilized in single-carrier systems too, by going before each transmitted information square of N length by a CP of length , while utilizing frequency area evening out at the collector.

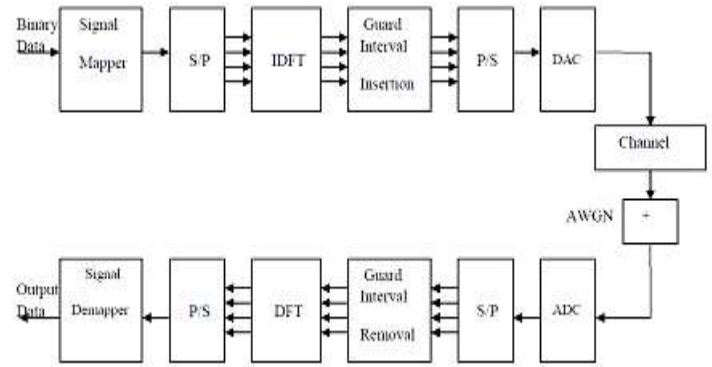

Fig. 1: The basic block diagram of an OFDM system in AWGN Channel

4. OFDM-IM

Phenomenal levels of range and vitality effectiveness are normal from fifth generation (5G) wireless systems to accomplish universal communications between anyone, anything, and whenever. Keeping in mind the end goal to achieve the testing destinations of 5G wireless systems, scientists have imagined novel physical layer (PHY) ideas, for example, gigantic multiple input multiple output (MIMO) systems and non-orthogonal multi-carrier communications plans. Be that as it may, the wireless network is as yet working day and night to think of new and more compelling arrangements toward 5G systems. There has been a developing enthusiasm for list modulation (IM) procedures in the course of recent years. IM, in which the files of the building squares of the considered communications systems are utilized to pass on extra data bits, is a novel advanced balance conspire with high ghostly and vitality proficiency. Spatial modulation (SM) and Orthogonal frequency division multiplexing with IM (OFDM-IM) plans, where the relating index balanced building squares are the transmit recieving wires of a MIMO system and the subcarriers of an OFDM system, separately, show up as two intriguing and also encouraging uses of the IM idea. SM systems have pulled in noteworthy considgenerationtion in the course of recent years. Despite the fact that having solid and settled contenders, for example, vertical Bell Labs layered space-time (V-BLAST) and space-time coding (STC) systems, SM plans have been viewed as conceivable possibility for range and vitality proficient cutting edge MIMO systems. Then again, analysts have begun to investigate the capability of the IM idea for subcarriers of OFDM systems as of late, and it has been demonstrated that the OFDM-IM plan can give alluring favorable circumstances over traditional OFDM, which is an indispensable piece of numerous present wireless norms. This part is showing the fundamental standards of these two promising plans, SM and OFDM-IM, which are as yet holding up to be investigated by numerous specialists, and audit a portion of the ongoing intriguing outcomes in IM systems. Moreover, we talk about the execution situations of IM strategies for cutting edge wireless systems and system conceivable future research headings. Especially,

we move our concentration to summed up, upgraded, and quadrature IM plans and the use of IM strategies for multi-users MIMO (MU-MIMO) and helpful communications systems.

5. Performance Analysis

In previous sections we have discussed the trellis coded modulation scheme and orthogonal frequency division multiplexing IM, now to analysis the performance of our desired system we have to combine both trellis coded modulation and OFDM-IM system to get our desired result.

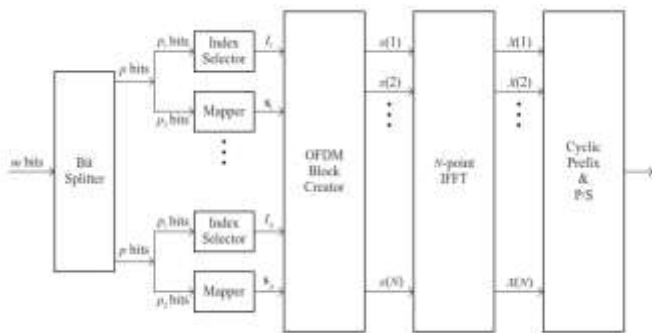

Fig. 2: OFDM IM Transmitter Block Diagram

- The essential point of our work is to decrease the Bit error rate(BER) with the help of TCM OFDM-IM.
- 1 x 2 encoder design is implemented based on data symbols having constant and varying values.
- The OFDM innovation we changed was outlined by QAM mapping for BER decrease and FFT/IFFT blocks.
- Implementation of the above OFDM system intended for BER diminishment completed over MATLAB 7.15.0.

Implementation points of interest are as per the following:

- First we select the number of active carriers out of total carriers and then we arbitrarily create the input bits for two different design having constant data bits and varying data bits utilizing "randint" work gave in MATLAB to the arbitrary generation of information.
- Encoding of information is done by "Trellis Encoding"
- QAM modulation is finished with the assistance of 16 states.
- After the signal gets trellis coded modulated followed by IFFT , we planned a channel for transmission, channel is readied utilizing "awgn" work.
- Take the FFT of received signal which is noisy in nature followed by the demodulator.
- At the reciever side for the decoding reason "Viterbi Detector " is utilized.
- Finally we'll compute the BER by comparing the transmitted bits and the bits received at the reciever.
- Bit Error Rate is computed utilizing the equation:

$$BER = \text{Error Bits}/\text{Length of Data .}$$

The software that we are utilizing for building up our algorithm is "MATLAB".

6. Simulation Result

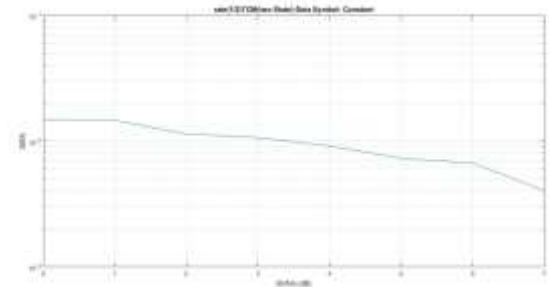

Fig. 3: BER Graph of 1x2 TCM Encoded OFDM-IM Data Symbol Constant

The above graph gives the bit error rate graph of 1 x 2 TCM coded OFDM-IM when the data symbol is constant. Here we can observe that with increase in SNR, bit error is vanishing at SNR=7.

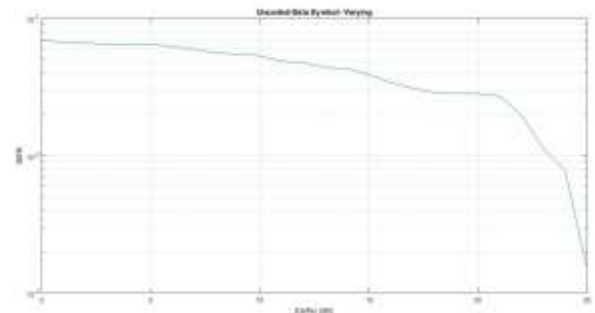

Fig. 4: BER Graph of Uncoded OFDM-IM Data Symbol Varying

The above graph gives the bit error rate graph of uncoded OFDM-IM when the data symbol is varying. Here we can observe that with increase in SNR, bit error is vanishing at SNR=25.

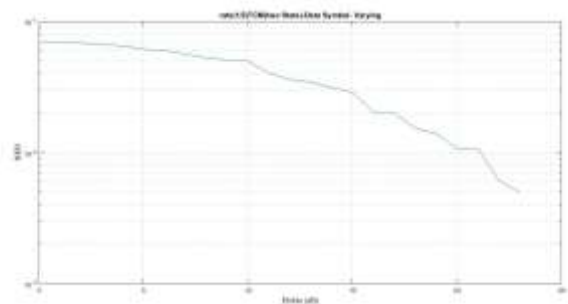

Fig. 5: BER Graph of 1x2 TCM Encoded OFDM-IM Data Symbol Varying

The above graph gives the bit error rate graph of 1 x 2 TCM coded OFDM-IM when the data symbol is varying. Here we

can observe that with increase in SNR, bit error is vanishing at SNR=23 for 1 x 2 encoder.

7. CONCLUSION

In our paper we combined the trellis coded modulation and OFDM-IM system having two transmitters and one receiver and analysed the performance of system using 16 QAM modulation with the design of 1 x 2 encoder having constant and varying data symbols which gives the satisfactory result of reduction in bit error rate.

REFERENCES

- [1] Rappaport, T., *Wireless Communication: Principles and Practice*. New Jersey: Prentice Hall, 1996.
- [2] Chang, R., "Synthesis of band limited Orthogonal Signals for multichannel data transmission." *Bell System Technical Journal*. vol. 46, (December 1996): pp. 1775-1796.
- [3] Proakis, J., *Digital Communications*. New York: McGraw-Hill, 1998.
- [4] Torrance, J., and Hanzo, L., "Comparative study of pilot symbol assisted modem systems." *Proceedings of IEEE conference on Radio Receivers and Associated Systems*, Bath UK, (September 1995): pp. 36-41.
- [5] Weinstein, S. and Ebert, P., "Data Transmission by Frequency Division Multiplexing using the Discrete Fourier Transform." *IEEE Transaction Communication Technology*, vol. COM-19, (October 1971): pp. 628-634.
- [6] Bello, P. A., "Selective Fading limitations of the KATHRYN modem and some system design considerations." *IEEE Transaction Communication Technology*. vol. COM-13, (1965): pp. 320-333.
- [7] Zimmerman, M. and Krisch, A., "The AN/GSC-10/KATHRYN/ variable rate data modem for HF radio." *IEEE Transaction Communication Technology*. vol. CCM15, (April 1967): pp. 197-205.
- [8] Hirosaki, B., "An analysis of automatic equalizers for orthogonally multiplexed QAM systems," *IEEE Transaction Communication Technology* . vol. COM-28, (January 1980): pp. 73-83.
- [9] Peled, A. and Ruiz, A., "Frequency Domain Data Transmission using Reduced Computational Complexity Algorithms." *Proceedings of International Conference on Acoustics*. vol. 3, (April 1980): pp. 964-967.
- [10] G. Ungerboeck, and I. Csajka, "On improving data-link performance by increasing channel alphabet and introducing sequence coding," in *Proc. IEEE Int. Symposium on Information Theory (ISIT)*, Sweden, 1976.
- [11] H. Imai, and S. Hirakawa, "A new multilevel coding method using error correcting codes," *IEEE Transactions on Information Theory*, vol. 23, pp. 371-377, May 1977.
- [12] V. Tarokh, N. Seshadri, and A. R. Calderbank, "Space-Time Codes for Wireless Communication: Code Construction," *IEEE 47th Vehicular Technology Conference*, vol. 2, pp. 637-641, Phoenix, Arizona, 4-7 May 1997.
- [13] V. Tarokh, N. Seshadri, and A.R. Calderbank, "Space-Time Codes for High Data Rate Wireless Communications: Performance Criterion and Code Construction", *IEEE Transactions on Information Theory*, vol. 44, no. 2, pp. 744-765, March 1998.
- [14] D. Agarwal, V. Tarokh, A. Naguib, and Nambi Seshadri, "Space-time coded OFDM for High Data Rate Wireless Communication over wideband," *Proc. VTC*, Ottawa, Canada, Vol. 3, pp. 2232-2236, 1998
- [15] Jinho Choi; Youngwook Ko, "TCM for OFDM-IM" ,*IEEE Wireless Communications Letters* Year: 2018, Volume: 7, Issue: 1 Pgenerations: 50 – 53, *IEEE Journals & Magazines*
- [16] R. Abu-alhiga and H. Haas, "Subcarrier-index modulation OFDM," in *Personal, Indoor and Mobile Radio Communications, 2009 IEEE 20th International Symposium on*, pp. 177-181, Sept 2009.
- [17] E. Basar, U. Aygolu, E. Panayirci, and H. Poor, "Orthogonal frequency division multiplexing with index modulation," *IEEE Trans. Signal Processing*, vol. 61, pp. 5536-5549, Nov 2013.
- [18] R. Fan, Y. J. Yu, and Y. L. Guan, "Generalization of orthogonal frequency division multiplexing with index modulation," *IEEE Trans. Wireless Communications*, vol. 14, pp. 5350-5359, Oct 2015.
- [19] E. Basar, "Multiple-input multiple-output OFDM with index modulation," *IEEE Signal Processing Letters*, vol. 22, pp. 2259-2263, Dec 2015.
- [20] E. Basar, "Index modulation techniques for 5G wireless networks," *IEEE Communications Magazine*, vol. 54, pp. 168-175, July 2016.
- [21] N. Ishikawa, S. Sugiura, and L. Hanzo, "Subcarrier-index modulation aided OFDM - will it work?," *IEEE Access*, vol. 4, pp. 2580-2593, 2016.
- [22] Y. Ko, "A tight upper bound on bit error rate of joint OFDM and multicarrier index keying," *IEEE Communications Letters*, vol. 18, pp. 1763-1766, Oct 2014.