

## MOBILITY ASSIST WITH STEP CLIMBER

Aby A Samuel<sup>1</sup>, Adithye Mathew<sup>2</sup>, Jaison Thomas Mathew<sup>3</sup>, Jestin Thomas Joseph<sup>4</sup>

\*\*\*

**Abstract** - *Mobility Assist is a multifunctional Sit-to-Stand and ambulation therapy device. Current state of the art devices include wheelchairs, walkers, standing frames and walking frames all of which are limited to only one aspect of mobility. These devices will not help to reduce the supporting weight on the legs and movements to the patient. Mobility Assist is suitable for any weak or handicapped people. The Mobility Assist supports patient from a seated to standing position, then allows them to proceed with the help of walker. As it is important to get the patient up and walking, this basic activity overcomes circulation problems, stimulates neural pathways and plays a role in creating sense of independence in the patient. This project helps the disabled and elderly persons in their difficulties. It can comfortably and securely lift up to a 75kg person. It gives mobility to the person in its standing position. It transfers major part of the weight to the ground. It can easily ascend or descend the stairs in his or her standing position and can be easily controlled.*

**Keywords-** Mobility Assist, Walkers.

### 1. INTRODUCTION

Independent mobility is a crucial element of independent living and quality of life. Over the last forty years, life expectancy has increased by 7 years, directly correlating with an older average working class, as well as the increased community involvement of retired individuals. However, health problems such as: osteoporosis, obesity, and many more result in limited mobility of these individuals. A stair-climbing walker could help these individuals, as well as those with physical disabilities and in physical rehabilitation regain their mobility and independence and ease their transition into the workforce.

The walker design is based loosely on the Rollator, with four legs. It will utilize a tri-wheel mechanism to ascend and descend stair-sets, which are deployed prior to use. Two linear articulate the wheel-base to the appropriate angle for ascent and descent. Each of these motions are controlled by a user activated, mechatronic control system.

Automation can be achieved through motorized, hydraulics, pneumatics, robotics, etc., of these sources, motorized form an attractive medium for low cost automation. Now a day's almost all the machines are

being atomized. The mobility assist is being atomized for the following reasons to achieve high safety, to reduce man power, to increase the efficiency of the vehicle, to reduce the work load, to reduce the fatigue of workers, less Maintenance cost. Mobility assist step climber is a device used by disabled people to enhance their personal mobility. There are many types of mobility assist available in the market like manual or powered and the choice of mobility assist depend upon the physical and mental ability of the user. This design could potentially improve the quality of life of individuals with physical disabilities, in physical rehabilitation, and of the elderly.

### 2. LITERATURE REVIEW

William C. Mann, Dianne Hurren, Machiko Tomita & Barbara Charvat (2009) discussed about Problems with Walkers Encountered by Elderly Persons, over 1.5 million persons use walkers, and 77 percent are 65 or older. Yet walkers rank high in terms of numbers of users experiencing problems in their use. This paper provides an overview of walker designs and features a review of the literature on studies of walkers and walker use, and an analysis of walker problems experienced by subjects in the University at Buffalo Consumer Assessments Study (CAS). Of 333 subjects in the CAS at the time of this analysis, 324 subjects reported at least some difficulty with ambulation, and 69 used a walker. Forty-two of the walker users reported problems relating to 46 walkers they owned. Fifty-seven percent of the problems were categorized as "difficult and/or dangerous" to use, pointing to the need for careful professional assessment, prescription and follow-up. A relatively small percentage (4 percent) of walker owners cited stigma as a problem. [1]

Joshua Finkel M.A.Sc. , Geoff Fernie Ph.D. and P.Eng. & William Cleghorn Ph.D. and P.Eng. (2010) discussed about the Guideline for the Design of a Four-Wheeled Walker, more people use assistive technology devices to compensate for mobility impairments than for any other general type of impairment. Increasing numbers of people with mobility or balance problems use walkers with four wheels. Four-wheeled walkers are often outfitted with seats to make it possible to travel longer distances with intermediate resting periods. The dangers of sitting on a parked walker are well known. Many physiotherapists tell walker users to park the walker

against a wall to prevent injury in case the user forgets to apply the brakes or the brakes fail. To design a safer walker that can be used for sitting, the demands placed on it must be measured. With these data, three modes of walker instability must be considered: first, the brakes may hold but the wheels may slide along the ground; second, the entire walker may tip over; and third, the brakes may fail to hold the wheels in place, and they may begin to roll. Mathematical models can be constructed to simulate how different walker designs will perform. By this process, design improvements can be made for existing walkers, and future walker designs can also be proposed. [2]

Dr. Anurag Purwar Dr. Hari Pillai Thomas Galeotafiore (2016) discussed about Mobility Assist, a sit to stand device to improve quality of life and independence for persons with functional limitations. It assists elderly and disabled people with lower-body debilitating ailments to comfortably stand up, sit down, and walk with fall arrest and stability support. Unlike any other product in the market, this is the first device that lifts and lowers individuals along the natural path of motion trajectories of human body, which reduces stresses on muscles and joints and stimulates functional neural pathways. The mobility assist and the underlying technology are at the cusp of creation of a successful product that could potentially enable millions of disabled people around the world to live with their loved ones or in ALFs independently and with dignity. Apart from the patients, the care givers also stand to benefit from this device by potentially reducing costly, life threatening back-injuries to them.[3]

Stair climbing has been carried out with robots using different types of locomotion. One can roughly distinguish wheeled, legged, and tracked robots.

### A. Wheeled Robots

Wheeled robots usually have to resort to mechanic extensions to overcome stairs. One application of such a technique is in-patient rehabilitation, where stair climbing could greatly enhance mobility, and thus quality of life, of people confined to wheelchairs. Lawn and Ishimatsu present a stair-climbing wheelchair using two (forward and rear) articulated wheel clusters attached to movable appendages. The robot is equipped with step-contact sensors, but relies on user steering and is thus only semi-autonomous.

### B. Legged Robots

In Figliolini and Ceccarelli present the architecture of the bipedal robot EP-WAR2, that uses electro-pneumatic actuators and suction cups for locomotion. In order to climb stairs, the robot relies on an open-loop control algorithm implemented as a finite-state machine. The main limitation of the approach is that operating in a different staircase necessitates manual recalibration.

Albert et al. Implemented a stair-climbing algorithm on the bipedal robot BART-UH. The authors employ stereo vision and the projection of a laser line in order to estimate stair dimensions. These are then used in a planning algorithm that produces piecewise analytical joint trajectories. The trajectory parameters are tabulated for different stair dimensions and interpolated as needed. Therefore, BART-UH can be considered an autonomous stair climber. However, the demanding control of a legged robot, due to its higher center of gravity and its intricate actuation, result in high computational load and overall system complexity. This severely limits the robot's speed during stair climbing. The humanoid robots of Sony and Honda, QRIO and ASIMO, are also capable of autonomous stair climbing. QRIO employs stereo vision to segment planar surfaces. These surfaces are used in a path planning algorithm that allows the robot to climb up and down stairs, sills and ledges.

In Hirai et al. outline the foot placement algorithm employed in Honda's humanoid ASIMO. Both robots use dense stereo vision, requiring the robots to move slowly in order to ensure image quality. Stair climbing with a hexapod robot has been demonstrated by Moore et al. . The robot RHex makes use of a special curved leg design and pre-programmed leg trajectories, rendering it capable to climb stairs of various dimensions. The employed algorithm, however, is strictly open-loop. It is thus unable to prevent collisions with the stair walls or balustrades, and cannot compensate large heading deviations induced by slippage or shocks.

### 3. METHODOLOGY

The method best suited for our project, due to flexibility and immediacy of response was to conduct different surveys. We conducted surveys in different hospitals, old aged homes, neighborhoods. We enquired different patients having different mobility problems. By considering these problems we categorized these patients into three groups:

Old aged users: People of age group of 60 and above facing different mobility issues like balanced problems.

Permanent users: People facing mobility problems for their entire life due to Multiple Sclerosis, Hemiplegia (when half of a person’s body is paralyzed often due to a stroke), Traumatic brain injury, etc.

After the survey, the requirements for the walker were calculated and final design of the prototype was made.

The main components are given below:

- Pneumatic cylinder
- Frame
- Wheel
- Dc motor
- Battery
- Screw rod
- Bearing

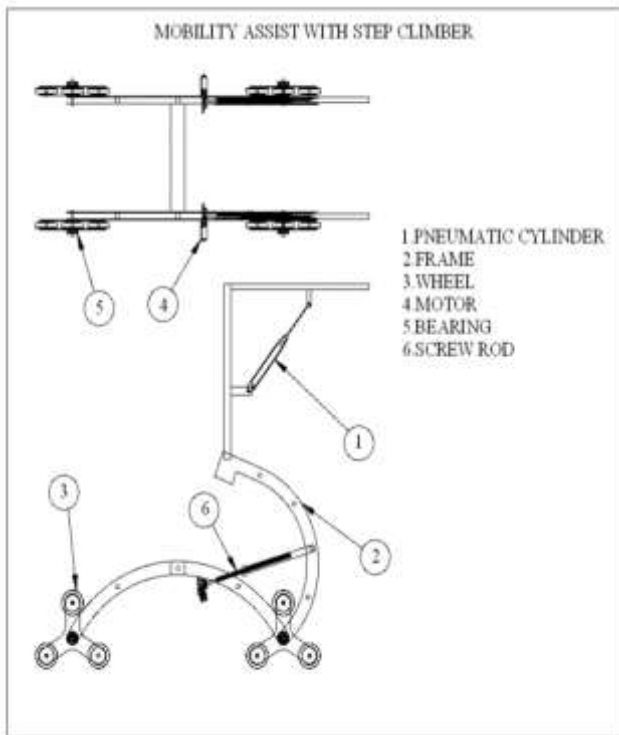

Figure 3.1 mobility assist with step climber



Figure 3.3 cad design of mobility assist

This project consists of frame, dc motor, battery, screw rod, pneumatic cylinder, wheel and bearing. The frame is mounted with the step climbing wheel. The pneumatic cylinder is mainly used for the purpose of lifting the climber while moving up and down the steps. The screw rod is mounted with the Dc motor and the Dc motor get the power from the battery. When the Dc motor is ON, the screw rod gets rotated forward and backward direction for lifting the person easily. The screw rod moves forward and backward when there is a variation in the height of the steps.

#### 4. RESULTS AND DISCUSSION

A prototype showing the mechanism of mobility assist used in sit to stand and ambulation is designed and fabricated. It can be implemented in hospitals and home for sit to stand and ambulation of patients facing mobility problems, successfully fulfilling the safety standards and design constrains. The designed system is capable of carrying a load of 75kg, mainly with the help of lead screw and it can be improved by using pneumatic cylinder for carrying a load of 130kg.

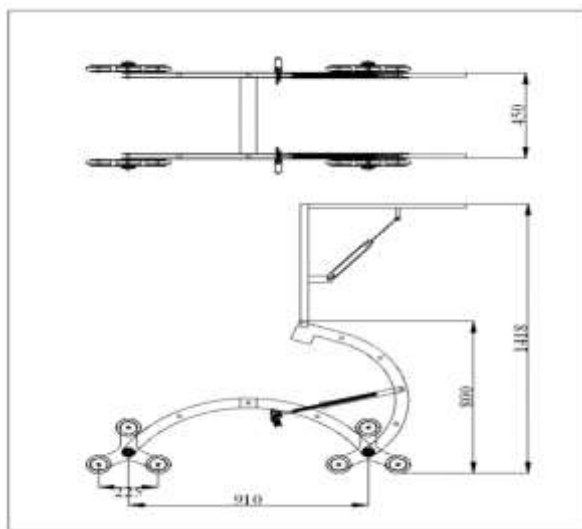

FIGURE 3.2 DESIGN OF MOBILITY ASSIST

Durability and maintenance considerations played an important role in design. Maintenance requirements are minimized. Space, versatility, and simplicity were all rated at the same level of importance. The lift has a low frame and folds into a very compact space.

The project can be later be implemented with pneumatic cylinder which increases load carrying capacity and also by providing proximity sensors which increase accuracy of movement and safety.

### CONCLUSION

This project work has provided us an excellent opportunity and experience, to use our limited knowledge. We gained a lot of practical knowledge regarding, planning, purchasing, assembling and machining while doing this project work. We feel that the project work is a good solution to bridge the gaps between the institution and the industries. The mobility assist with step climber is working with satisfactory conditions. We were able to understand the difficulties in maintaining the tolerances and also the quality. We have done to our ability and skill making maximum use of available facilities.

### ACKNOWLEDGMENT

First and foremost we take this opportunity to express our deepest sense of gratitude to Prof. Sajan Thomas, project guide and Professor, Mechanical department for his guidance during our project work. We would like to extend our gratitude to all the respected faculty and staff members of our department who have always encouraged and supported in doing our work. We would also like to thank the authors of various research articles and handbook we referred to during the course of our project.

### REFERENCES

- [1] William C. Mann, Dianne Hurren, Machiko Tomita & Barbara Charvat "Problems With Walkers Encountered by Elderly Persons", 2009.
- [2] Joshua Finkel M.A.Sc. , Geoff Fernie Ph.D. and P.Eng. & William Cleghorn Ph.D. and P.Eng. " Guideline for the Design of a Four-Wheeled Walker", 2010.
- [3] Dr. Anurag Purwar Dr. Hari Pillai Thomas Galeotafiore Mobility Assist, A Sit To Stand Device To Improve Quality Of Life And Independence For Persons With Functional Limitations", 2016.

### AUTHOR INFORMATION



**Adithye Mathew,**  
Department of Mechanical  
Engineering,  
Saintgits College of Engineering



**Aby A Samuel ,**  
Department of Mechanical  
Engineering,  
Saintgits College of Engineering



**Jaison Thomas Mathew,**  
Department of Mechanical  
Engineering,  
Saintgits College of Engineering



**Jestin Thomas Joseph,**  
Department of Mechanical  
Engineering,  
Saintgits College of Engineering

### MENTOR INFORMATION

**Prof. Sajan Thomas,**  
Professor, Department of Mechanical Engineering,  
Saintgits College of Engineering.