

Monitoring and Detection of Short Circuit Fault in Transformer

Kshitija Patole, Sheetal Pawar, Shweta Kumthekar, Neha Panpatte

Abstract – In the power system it is very difficult and important to find out the short circuit faults occurring in the transformer. These internal faults are very dangerous it may damage the whole system temporary or permanently. It is more difficult to detect internal fault in small rating of transformer. Now a days we have a one conventional method i.e. buchholz relay but this method is depends upon the formation of gases produced after occurring of a fault, hence we are using this method. In these method we are using the search coil to identify the turn-to-turn fault location in power transformer by core flux based technique in which we are using turns which are isolated as pursuit loops (search coils) must be wrapped around the transformer legs to detect the related passing flux. These search coils will not change the structure of transformer. Since going equivalent flux through a transformer center leg in ordinary condition actuates parallel voltages demonstrates the blame occurrence in that stage. Changes in the core flux indicates that the turn to turn fault is occurred. This can be done by some simulation process and experimental tests and obtain result show that this method is more suitable for short circuit faults, identify the phase and region in which fault is occurred.

1. INTRODUCTION

The power transformer is the main equipment for the generation and distribution process. For every transformer protections and windings are the most basic component. The main fault occur on transformer is short circuit of turns due to the failure of insulation which may produce harm in winding on transformer including winding. Insulation is the most important part of the transformer in case of safety. Failure of insulation system causes breakdown in insulation and creates inter turn faults. Internal turn-to-turn faults are the most dangerous types of faults which is found in the transformer. If short circuit fault has not been detected as earlier as possible it causes more critical faults in the transformer. Such as phase-to-phase or phase-to-ground fault. That's why, immediate indication of short circuit fault is important to provide safety for whole power system.[1] following are three methods categorized for turn-to-turn fault detection-

- i. Current and voltage components based
- ii. Frequency characteristic based
- iii. Flux based

Since we are using the method which is based on measuring the core flux by the search coils. Mostly a short circuit found

on few turns of transformer ending will result in severe short circuit in other neighboring turns. As experimental results the differential relay used in transformer is not so far efficient to found such turn to turn fault. Therefore fast and reliable method for detection of turn to turn fault is difficult work in entire electrical system.[2]

Search coil is more reliable and simple sensor for that detects the turn to turn fault by sensing the flux in transformer.

In search coil faradays law of electromagnetic induction principle is used. When fault occurs in winding the flux in conductor coil get change and voltage will generate which is related with changes occurred in the fluxes. The sensing device is used to show the magnetic flux which is too small as 20fT (2×10^{-5} nT) there is no limitations for their sensitivity range. their proper frequency range from 1 Hz to 1 Mhz.[3]

The method used in [4,5] is based on leakage flux. this method is used during turn to turn faults in winding for sensing the leakage flux in these method some sensing device are placed next to HV winding. (it can be proximity sensor) leakage flux occurs during TTFs. In this TTF detection the gap between HV winding and sensing element should be allowable. If it affects the whole construction of tank and transformer then it is important to change a design. In case of online problem the circuit used for detection of TTF is get protected from high voltage surge and all not able to found faulty location of abnormal condition at winding.

In [6] Search coil method, The search coil is placed near the HV winding in transformer, is used to detection of turn to turn fault. In normal condition of search coil, core flux and particular part of leakage flux are passing through the search coil, In search coils during TTF there is drop of fault in the particular part and rise in flux leakage where it results that decreasing in the magnetic flux line that are travel through the search coil, due to these the generated voltage in respective search coil will drop out. These structure has been presented in this paper is for up to 2.5 KVA transformer therefore it is mandatory to provide a insulation layer between the search coil in HV winding which is used for online application where high voltage power transformer get permanently installed. somewhere for small TTF travelling flux cannot be changed which is also enable to change. Therefore the high sensitivity does not get effectively by this method.

HARDWARE'S FOR SYSTEM DESIGN

3 phase Transformer

Regulated Power Supply

Microcontroller Atmega328p

Transformer

16*2 LCD Circuit

Temperature Sensor

Vibration Sensor Oil Level Sensor

Oil Quality sensor

GSM Modem

Buzzer

TRANSFORMER



Specifications-

Output-0.25KVA

Voltage-V1/V2=415/110

Frequency-50Hz

No of phases- 3phase

Cooling-Fan

Type-Core

Type of winding connection-Delta Star

Winding Material-Copper

Insulation Level-F Class

Efficiency-0.9

Noise level-Below 40dB

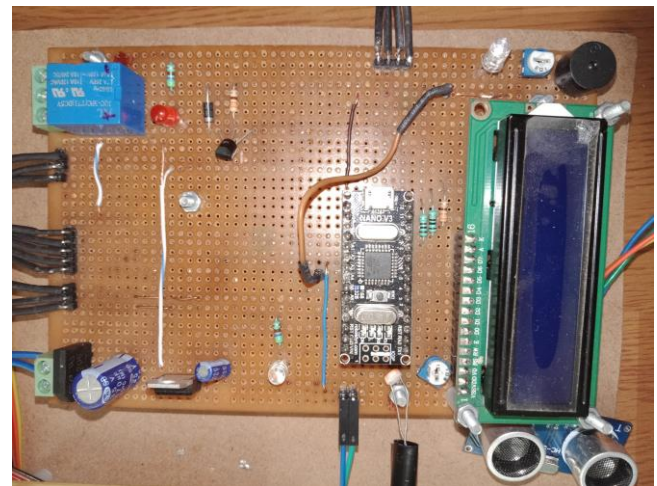

RELAY CIRCUIT

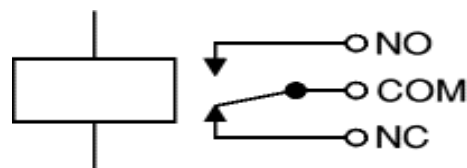

A electromagnetic coil is used in the electromagnetic relay that moves a metal arm to make and break an electrical connection.

Electromechanical relays can be used for switching of high current and also AC devices.

In such type of electromagnetic relay isolation is provided between the control signal and the load and it having low cost.

COM = Common, always connect to this; it is the moving part of the switch.

NC = Normally Closed, COM is connected to this when the relay coil is off.

NO = Normally Open, COM is connected to this when the relay coil is on.

POWER SUPPLY

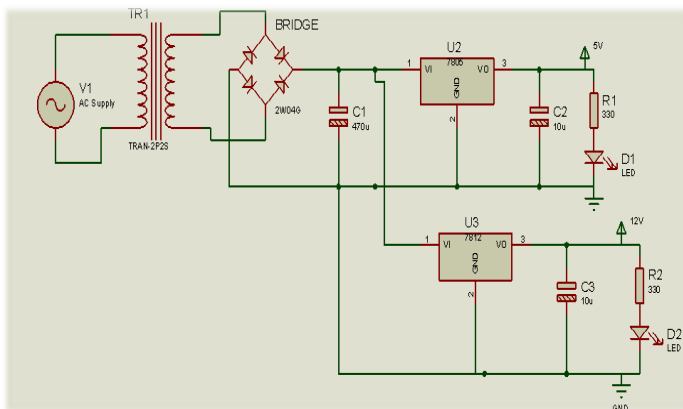

Power supply is a electrical device. power supply is mainly used to provide electrical power to the electrical load. The main function of power supply to converts electrical current from source to the voltage, current and frequency to the load.

It also termed as power converters.

Power supply performs another function like limiting the current drawn by load to safe level. it turn off the current in case of the fault also used as power conditioner to prevent electrical noise.

All power supply consist power input which is used to receive energy in the form of electric current and one more for power output connection that deliver current to the load

AURDINO NANO IC

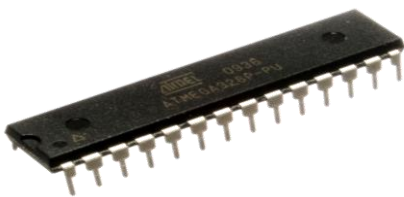

A microcontroller contains a processor core, memory, and programmable input/output peripherals.

Microcontrollers are used in automatic operator products and devices, such as

Better control on engine

Useful in medical equipment's

Remotely operated device,

Office machines and Appliances,

Toys and other embedded systems.

Aurdino nano consist of a CPU, ROM, RAM and I/O ports, and which is used for complicated and important task

.LDR

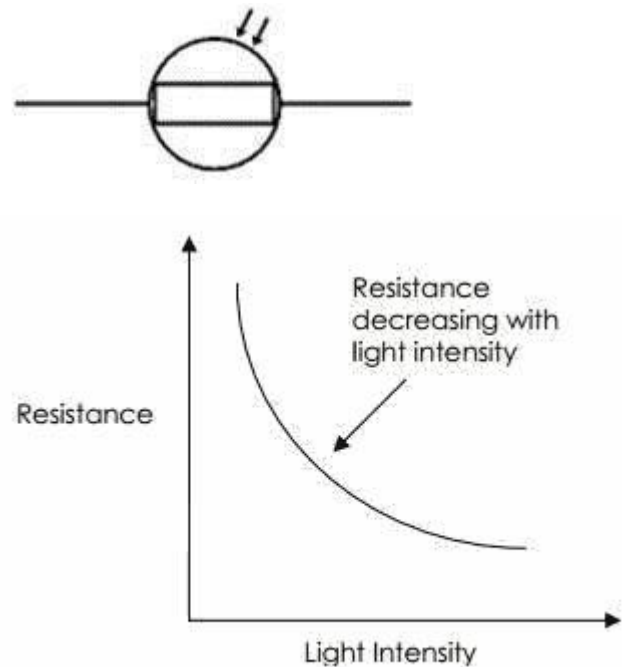

In LDR variation in light intensity affects the resistance that falls on it then this allows to be used in Light Sensing circuit.LDR is Resistance Decreases with the strength of light.For that we are using semiconductor material which have high resistance.

When Light falls on the device the Electronic energy falls on the photon .so that the photons Jump into the Conductive Band and elctricity conducts in the conduction band .if lower the strength of resistance it makes the power high.

ULTRASONIC SENSOR

Ultrasonic sensor device which is used to measure the distance to an object by using a sound wave. it consists of transmitter and receiver the distance is measured by sending wave at specified frequency and receiver listening for that. sound wave to Bounce a back .by recording time between the sound wave generated and sound wave bouncing back. Some objects may not be detects by ultrasonic sensor. this is because this shape and the position of object due to which are sound waves bounces off the object. the ultrasonic sensor send high frequency sound pulses and take how much time takes for the echo of sound to reflect back ultrasonic sensor.

It consist of opening on its front, one opening transmit ultrasonic waves and another receives them. the speed of sound is a 341 Meter per second in air. it uses the information between sending and receiving sounds. to determine the distance to an object. it is determined by following the mathematical equation

$$\text{Distance} = (\text{speed of sound} * \text{time taken}) / 2$$

following parameters can be measured by ultrasonic sensor. without any contacts distance, level, diameter, presence, position etc. it takes accurate measurement of many difficult environment and unusual Material. the measurements are unaffected by material ,surface, light ,dust.

It consists a transmitter and receiver which are separate units are also embedded together as a single unit. all material which reflect sound can be Can be detected regardless of the colour

VOLTAGE DIVIDER CIRCUIT

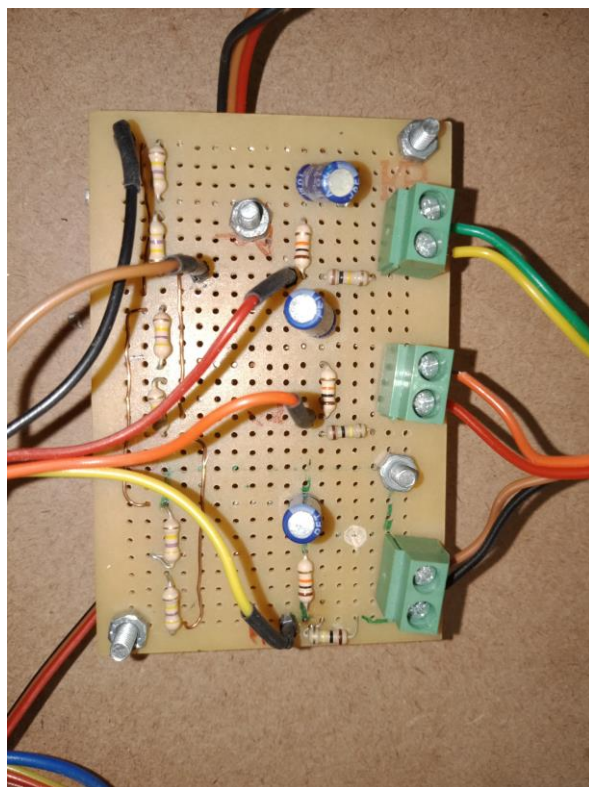

Voltage divider is a circuit which terns a large voltage into smaller one. using two series resistance and input voltage, we can create an output voltage. this is the fraction of the input. if learning Ohm's law was like being introduced to the

ABCs .voltage dividers are one of the most fundamental circuit in electronics .

It is a plastic linear circuit that produces that is a fraction of input input voltage. Example- resistors are connected in series in between them and the supply voltage is applied across it and The output voltage emerging from the connection between them. Distributor in and components of divider.

SSR CIRCUIT

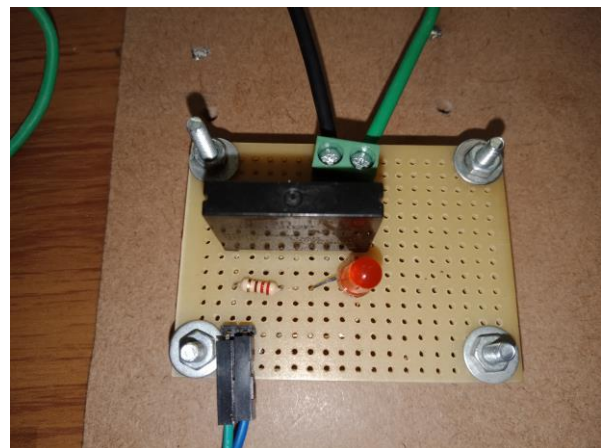

SSR stands for solid state relay it is based on a single MOSFET. multiple MOSFET in a parallel array, can work good for DC loads MOSFET. Has an substrate diode which can conduct in reverse direction. unable to block current in both directions. AC operation to Hospet are connected back to back with their sorce pins tied together instantly. in AC circuits, SCR relay sweets at the points of zero current.

SSR is characterized by following activating Input voltage, current output voltage. it can be AC or DC voltage drop, thermal resistance.

Following are the advantages of SSR

1. The size of SSR is smaller than mechanical relay for same rating.
2. Operation is silent, clean, no sparking. it can be used in explosive environment

LM35

Mostly we are calculating the environmental quantity i.e temperature because whole sysytem is get affected due to changes in the temperature,so we have to maintain the

temperature within its certain limit such as chemical, physical, electronic, and mechanical

LM35 is circuit in which voltage output is nothing but the output of LM35. is more beneficial than the other conventional methods i.e linear method. it don't require any external calibration, it makes control circuitary more easy and interfacing and interfacing for reading purpose.

Temp sensor is a device which collects the data and then it converted into the understandable format it may be analog or digital which is easily understood by the observer.

It is used in high voltage application, control of environmental quantities, observing, monitoring. it determines the quantity in each stage i.e solid, liquid, and gases also.

LM35 have more accuracy as compare to the other conventional temperature sensors

Scale Factor-0.1 voltage per degree Celsius.

It has Exactness of 0.4 degree Celsius at normal temperature, low heating capability.

CONTACTOR

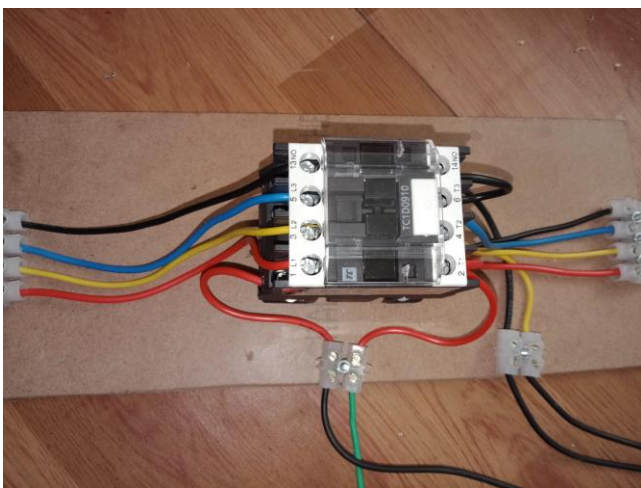

contactor is electrical device which is used for switching of an electrical power circuit. it is controlled by a circuit has a lower power than a switch circuit 24 volt coil controlling a 230 volt motor switch. There are many contactor are available depending upon its capacity and features. it is not operate in a short circuit like a circuit breaker. contactor has a capacities from breaking current several amperes to thousands of amperes. 24 volt DC too many kilovolts. the size of contactor is a small which can be pickup with the use of one hand.

construction- contactor has three main components. the contacts consist of one is power contact, auxiliary contact and contact. the contacts of a contactor are the current carrying part of the electromagnetic provides the driving force to close the contact. the enclosure frame is also provided for the contact. These enclosure is made up of bakelite, thermosetting plastic and nylon 6. it is provided for insulation and protection purpose of a contacts. and also

protection against the personal touching. the magnetic blown out are provided for a lengthening the arc and to move the arc.

RESULTS

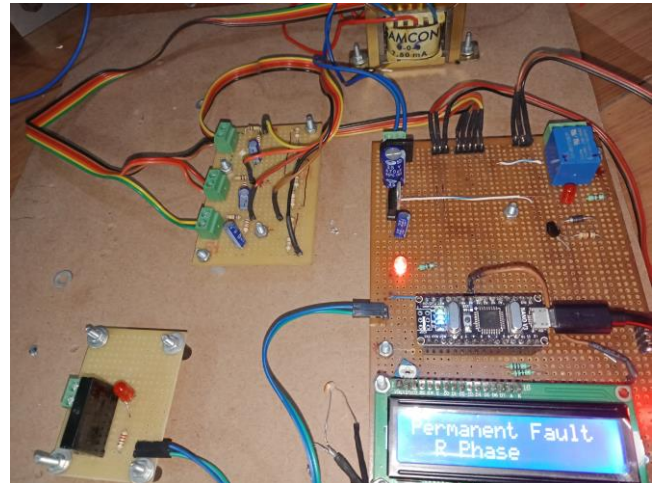

Short circuit occurred on R phase

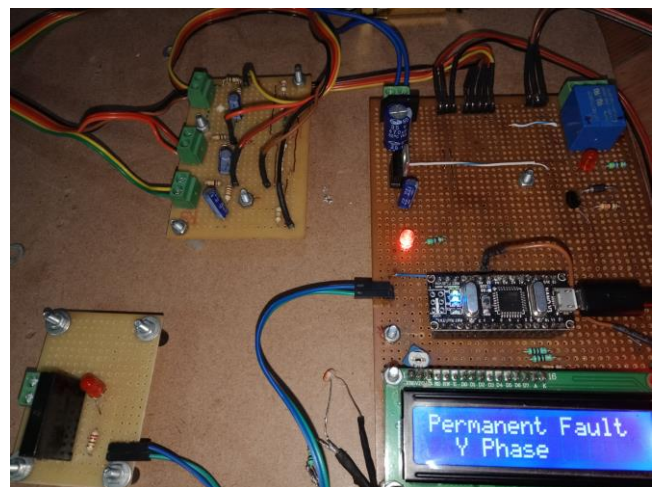

Short circuit occurred on Y phase

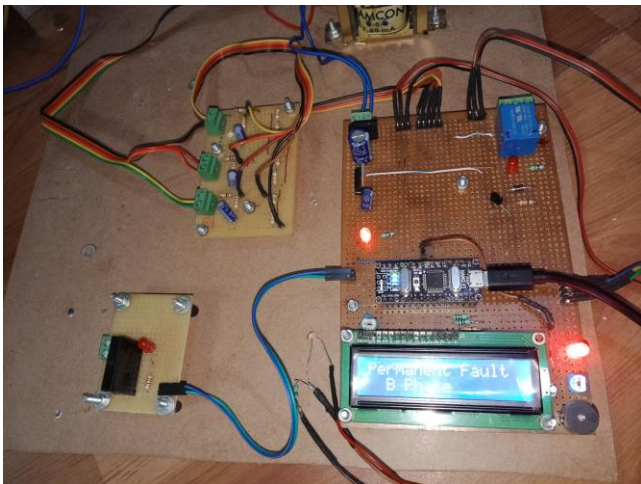

Short circuit occurred on B phase

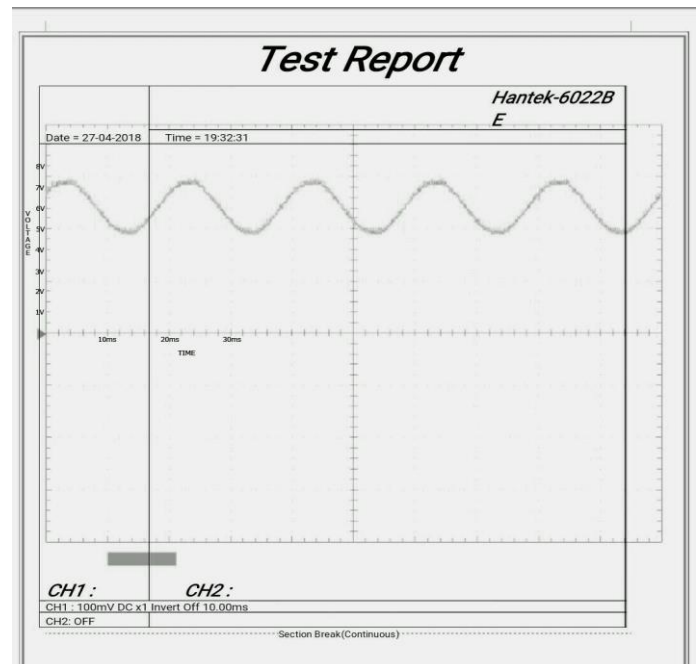

Waveform under fault condition on R,Y,B phase

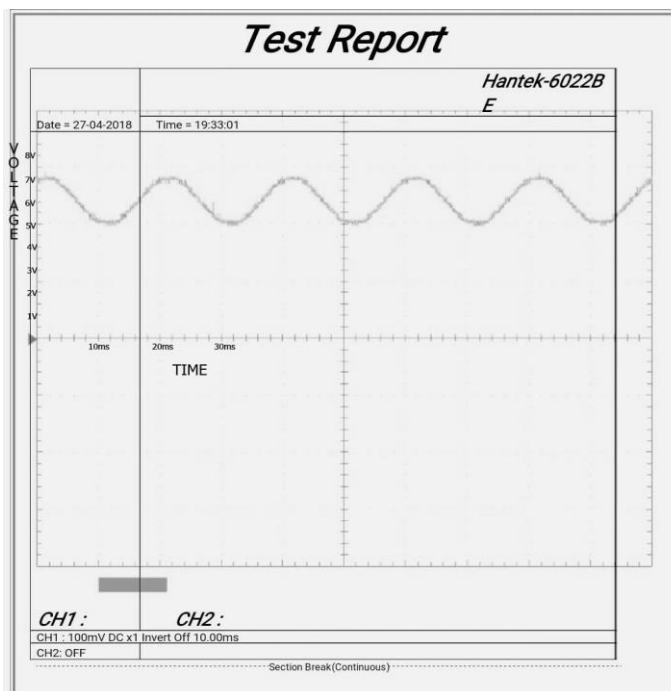

Waveform under normal working condition on R,Y,B phase

REFERENCES

- 1) Khramshin Vadim Rifkhatovich, Evdokimvo A, Nikolaev A.A ..Monitoring Technical State of Power Transformers is a Necessary Condition of the Smart Grid Technology Introduction within the Industrial Electrical Network 2015 IEEE
- 2) F. Haghjoo, M. Mostafaci, M. Mohammadzadeh.. A Novel Flux- Based Protection Scheme for Power Transformers 2013AIJ- IEEE
- 3) Farhad Haghjoo, Mohsen Mostafaei..Flux-Based Method To Diagnose and Identify the Location of Turn-to-Turn Fault in Transformers.2015 IET Journal
- 4) Cabanas, M.F., Melero, M.G., Pedrayes, F., et al.: 'A new online method based onleakage flux analysis for the early detection and location of insulating failures in power transformers: application to remote condition monitoring', IEEE Trans.Power Deliv., 2007, 22, (3), pp. 1591–1602
- 5) Hajiaghasi, S., Abbaszade, K., Paidarnia, H.: 'A new method for modeling and Analyzing the increments of leakage flux in power transformer in inter-turn faultcondition'. (in Persian), 28th Int. Power System Conf., Tehran, Iran, 2013
- 6) Venikar, P.A., Ballal, M.S., Umre, B.S., et al.: 'Search coil transformer basedinter-turn fault detection'. The 18th National Power Systems Conf. (NPSC), 2014

