

Harmonics & Neutral to Ground Voltage Reduction using Isolation Transformer

Gorakhshnath Shahu Jadhav¹, Shubhada Vasudeo Sarode^{*2}

¹Bachelor of Electrical Engg. ZCOER,Pune

²Bachelor of Electrical Engg. ZCOER,Pune

Abstract - Now a days non- linear load used in industries, result in the harmonics current and voltage in disturbances system. Result in increases NG voltage as well as harmonics disturbances can create a problem to improve power quality. It is important to use fabricated isolation transformer with copper strip which is located between primary and secondary windings of transformer. The conclusion of non linear load and analysis has been studied with the help of Proteus software and reduction in THD.

Key Words: : Isolation transformer, Distribution system, harmonic distortion , voltage reduction.

1.INTRODUCTION

Massive buildings and work places have a 3 ph source where the load is connected with 1ph supply between line and neutral in a distribution system both linear as well as non linear load are present. Due the high harmonic voltage there is failure of equipment and linear load losses. Thus reduction of harmonic voltage is improve power quality.

The main problem in a distribution system is NG voltage. It is nothing but potential measure between neutral conductor and ground conductor. As we know an isolation transformer is used for international safety and standards in

electronic equipment has been increased drastically in last several years. Which uses non linear load like resistive, inductive and capacitive etc (rectifier, microwave oven, computer, printer etc).increasing use of power electronic devices there will be a chance of increase in harmonics.

cannot eliminate but can be reduce at certain level. Actually it should be zero .in any operation immediate response of neutral to ground voltage is occurred at 1v. It is necessary that neutral to ground voltage is less than 0.5v so that there is no cause and if it goes beyond this voltages or higher than measure problem occur.

2.METHODOLOGY

Due to the non-linear load, the harmonics and the neutral to ground voltage is generated. Reduction of the NG voltage and harmonics by using isolation transformer is the main purpose of this power quality analysis. To measure the power quality which means harmonics which is giving us the minimum, maximum values of the voltage, voltage and current imbalance, the power quality analyser is used.

Firstly power quality analyser analyse the power . it monitors the incoming supply and analyse the incoming power without isolation transformer and measure the THD and neutral to ground voltage. Then with connecting the isolation transformer, analyser measure the THD and neutral.

3.HARMONICS

Harmonic is the voltage and current waveform of integral multiple of fundamental frequency. In below fig we observe that when voltage is apply across the power supply then current will be approximately zero until firing critical angle reach to sine wave. This value of current will be higher with respect to time when over time the peak of sine wave and the value is smaller when firing critical voltage is the below the side of sine wave. At that time the device get off and the then current will be zero.

If voltage apply across resistive load then harmonics generated because of harmonics generated current distorted. There are two types of harmonics indices.

- Total harmonic distortion (THD)
- Total demand distortion (TDD)

In below fig.3.1 shown third harmonics and fifth harmonic waveform is shown.

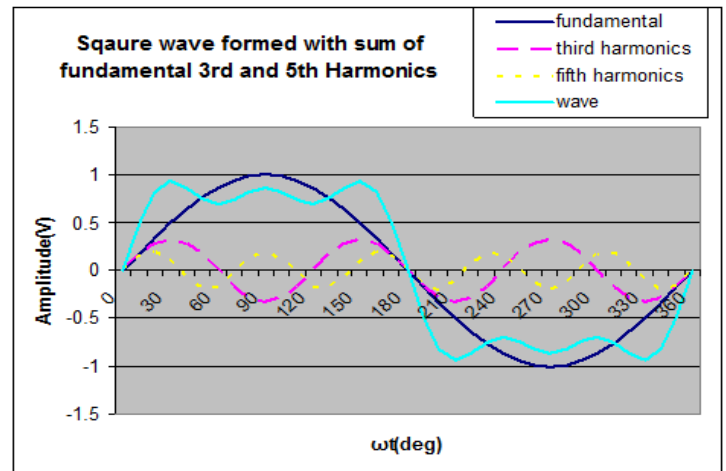

4. ISOLATION TRANSFORMER

In below fig the structural diagram of isolation transformer is shown in which primary and secondary winding are separated with the help of electrostatic shield which made of non magnetic conducting material (copper, aluminium) which connects to the ground thus it is used in the project to stop the noise of the system when past through the transformer the electronic sensitive equipment, isolation transformer acts as condition device as well as it reduces loads from transient and noise from utility

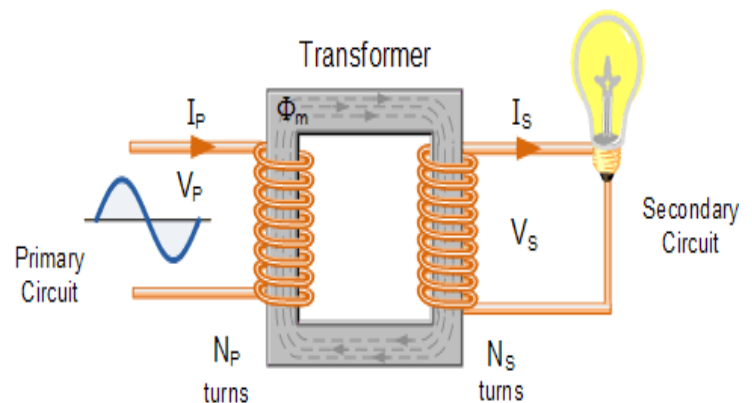

Fig4.1: Concept of isolation transformer

4.1 CALCULATION

A) NOMENCLATURE

- THD Total Harmonics distortion
- TDD Total Demand distortion
- VS Supply Voltage
- VA Volt Ampere
- KVA Kilo volt Ampere
- NG Neutral to Ground Voltage

B. SPECIFICATION

1. Step Down Transformer – 9V,500mA
2. Bridge IC
3. Voltage Regulator IC 7805.
4. C1 = 1000uF/25V- Electrolytic Capacitor
5. C2 ,C4 = 0.1uF- Ceramic Capacitor
6. C3 = 220uF/25V - Electrolytic Capacitor

C. CALCULATION

Output voltage = 5V
 Drop out Voltage = 2V
 So,
 $V_{dc} = 5 + 2 = 7V$

We Know,

$$V_{dc} = 2V_m / \pi$$

$$V_m = V_{dc} * \pi / 2$$

$$= 10.9V$$

Drop out voltage of one diode = 0.7V
 Drop out voltage of two diode = 1.4V

$$V_{m1} = V_m + 1.4$$

$$= 12.39V$$

$$V_{rms} = V_{m1} / \sqrt{2}$$

$$= 8.76V$$

So we select transformer of 9V

Therefore,

$$I_m = I_{dc} * \pi / 2$$

$$= 400 * \pi / 2$$

$$= 628 \text{ mA}$$

$$I_{rms} = I_m / \sqrt{2}$$

$$= 444.06 \text{ mA}$$

Assume transformer rating of 0-9V/500mA

Filter Capacitor design

$$R = V_{dc} / I_{dc}$$

$$= 17.5 \text{ Ohms}$$

$$V_r = 2(V_{m1} - V_{dc})$$

$$= 10.78V$$

$$C = V_{dc} * (F * R * V_r)$$

$$= 371.05 \text{ uF}$$

Circuit diagram of power supply

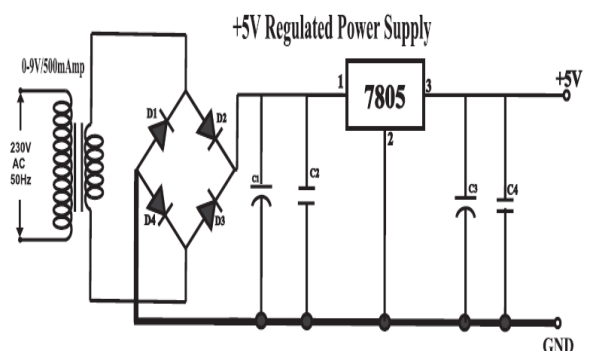
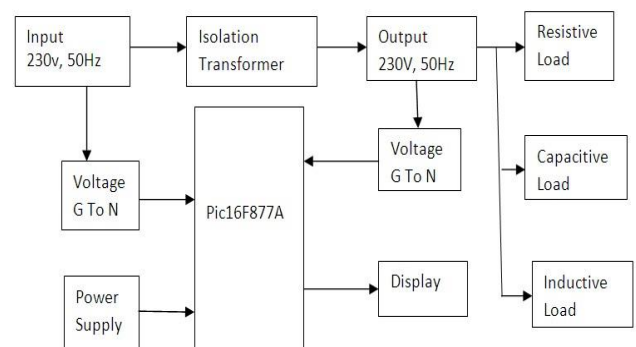

Fig4.2 circuit Diagram of power supply

5. BLOCK DIAGRAM



6.WORKING PRICIPLE

The working of isolation transformer is same the other transformer. In this transformer the two electromagnet are used that are wound on each other , as it allows the primary side coil to induce the current on secondary side coil. The voltage is decreased, when the number of windings are more on primary side than the secondary . Similarly the voltage is increased , when the number of windings are less on primary side coil than secondary . Instead of having the direct connection the isolation transformer are having the two coils i.e primary and secondary which are wound the same to kept the voltage value same only they separate two circuit inducing the current form primary side to secondary side.

7. HARDWARE COMPONENTS:

- Microcontroller
- Power supplies
- Transformer
- LCD

8.RESULT

TOTAL HARMONIC DISTORTION				
HARMONIC	AMPLITUDE			
	input	inductive	resistive	capacitive
1	3.08	3.8	3.8	3.8
2	0.402	0.308	0.154	0.212
3	0.202	0.154	0.077	0.106
4	0.102	0.077	0.0385	0.053
5	0.52	0.0385	0.01925	0.0265
6	0.0253	0.01925	0.009625	0.01325
7	0.0125	0.009625	0.004813	0.006625
8	0.00612	0.004815	0.002406	0.0033125
9	0.0036	0.002406	0.001203	0.001656
10	0.0016	0.001203	0.000612	0.0008281
V_{THD}	15%	9.35%	4.67%	6.40%

TOTAL HARMONIC DISTORTION				
HARMONIC	AMPLITUDE			
	input	inductive	resistive	capacitive
1	1.235	0.992	0.82	0.71
2	0.45	0.225	0.195	0.21
3	0.225	0.1125	0.0975	0.105
4	0.1125	0.05625	0.0487	0.0525
5	0.05625	0.02812	0.0243	0.012625
6	0.028125	0.01406	0.01218	0.01312
7	0.01406	0.00703	0.00609	0.00656
8	0.007	0.003415	0.003046	0.00328
9	0.0035	0.00175	0.00152	0.00164
10	0.017	0.00087	0.000761	0.00082
I_{THD}	22%	7.28%	6.09%	8.45%

9.CONCLUSION

By using power quality analyzer at point A without isolation transformer measured value of THD % voltage is highest, but at point B with isolation transformer total THD is reduced. Therefore the 1st harmonics is reduced and eliminated respectively. Ideal value of N G voltage is zero but practically it is 0.5 to 1.0 or higher so with the help of isolation transformer neutral to ground voltage is reduced. For monitoring and analyzing harmonics and N G

voltage separate equipment is used but using isolation transformer harmonics and ground to neutral voltage is reduced at a time, so cost is reduced and stability is improved.

10. REFERENCES

- 1] M.A Shafie, H. Singh , M.Q.A Rahman-Harmonic and Neutral to Ground Voltage Reduction Using Isolation Transformer.
- 2] Fluke education partnership program ,2004,PQ measurement atreceptacle branch circuit , <http://www.flucke.com,30/1/2008>.
- 3] Chuck Thomas ata al."POWER quality in Medium and Large Commercial Buildings,"Senior PQ Engineer , EPRI,Nov2007
- 4] M.Izhar et al.,"Performance for passive and active power filter in reducing harmonics in the distribution system ," National Power & Energy Conference (PECon)2004 Proceedings.
- 5] Xiangning Lin, Jingguang Huang, LinjunZeng, and Zhiqian Q. Bo, -Analysis of Electromagnetic Transient and Adaptability of Second Harmonic Restraint Based Differential Protection of UHV Power Transformer.