

Design and Development of Miniature Wind Turbine

Pallav Dutta , Sudhangshu Sarkar , Ushnik Chakrabarti

Assistant.Professor, Dept. of Electrical Engineering, Narula Institute of Technology, West Bengal,

Abstract -: Wind Turbines are the oldest known method used to extract energy from the natural sources (wind in this case). With the changing weather and wind speed, it is not possible to produce high constant power from the wind turbine but a small-scale wind turbine can be used to power small appliances at home, and in moving vehicles. This project looks into the designing aspects for an innovative small-scale wind turbine designed for supplying electricity. The report includes content on design, enhancement, power management, manufacturing methods.

Key Words: wind turbine, small-scale wind turbine, non-conventional, design and development.

1. INTRODUCTION

With increasing awareness of global warming due to Carbon Dioxide produced from the burning fuels of automobiles, the use of natural energy source is coming into effect. Engineers are adapting the use of natural sources (e.g. wind, solar, hydro) to generate electricity. The use of wind turbine is one of the oldest known methods of extracting the energy from natural sources. Wind turbines are not well considered because they heavily depend on the wind blowing along with the geographical disturbance however, a small-scale wind turbine can be used to power car appliances reducing the cost of fuel burnt to produce equal amount of electricity. Wind turbine extracts energy from the wind to generate electricity. Just like any engineering design poses challenges, installing wind turbine on automobiles also poses various challenges. This report looks into the current designs of the small-scale wind turbine along with the market requirement followed by the design of an innovative wind turbine system. In the report areas such as current designs, power generation, blade design etc. The report also considers the development complications limiting the design enhancement such as noise, aesthetics, material cost, maintenance and other issues. These are the issue which affect the design, manufacturing.

2. The Wind & the Blades

2.1 Wind power calculations

Kinetic Energy of mass in motion given by:

$$E = \frac{1}{2}mv^2 \tag{1}$$

But the power is the rate of change of energy:

$$P = \frac{dE}{dt} \tag{2}$$

if the kinetic energy of the wind is considered to have constant velocity then the power of the wind can be calculated by:

$$P = \frac{1}{2}v^2 \frac{dm}{dt} \text{ where,}$$

$$\frac{dm}{dt} = \rho A \frac{dx}{dt} \tag{3}$$

as shown in Fig.1

$$\text{Therefore, } P = \frac{1}{2} \rho A v^3 \tag{4}$$

Where ρ is the Density, A is the Sweap area and v is the Velocity of the wind.

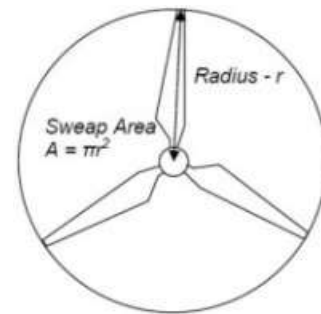

Fig:1: Sweap Area of blades

The above calculation only helps us to find out the wind power with specific wind velocity. The wind turbine however does not extract all the power from the wind. Some of the energy is used to overcome the profile drag created by the blade geometry and the leftover energy is allowed to pass through as extracting all the energy from the wind would mean accumulation of static pressure particles aft of wind turbine blades. Imagine an 'Axial Stream Tube' around a wind turbine as shown in Fig 2 if the energy is extracted between stage 2 and 3, the pressure accumulation would divert the incoming flow around the blade rather than passing through the blades. By extracting the power, the turbine reduces the wind kinetic energy. Therefore, the air moves more slowly downstream of turbine compare to the upstream. This accumulates wind behind the turbine sweep area (downstream) as its moving slowly after the energy extraction. As a result, the approaching (upstream) wind diverts around the turbine blades to avoid slow moving air. For these very reason 'there is an optimum amount of power to extract from a given disc diameter. [5]

2.2 Blades

Betz's limit places significant restriction on the power that can be extracted by the blades. The limitation means more blades there are, the less power each can extract. However, this allows us to reduce the blade length (span) and chord. The other factor influencing the number of blades is aesthetics: it is generally accepted that three-bladed turbines are less visually disturbing than one or two-bladed designs. Also, the number of blades adds to the weight which creates moment about the center (mast or pillar). This moment is counter acted by the moment generated by the weight of the tail fin. Therefore, increasing the number of blades would also require increasing the weight of the tail fin by changing the geometry or the distance its acting at from the center or by using a denser material for the tail fin. Blades generate lift and this lift provides acceleration for the angular rotation [5]. Hence the reason blades need to be manufactured precisely and increasing the number of blades would increase the cost of manufacturing.

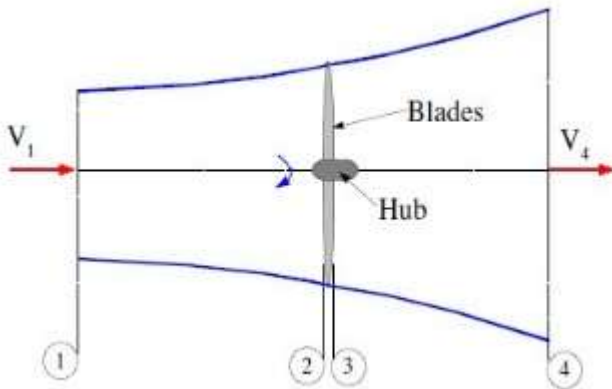

Fig-2: Airfoil structure of the blade.

3. PERMANENT MAGNET GENERATOR

Small scale wind power requires a cost effective and mechanically simple generator in order to be reliable energy source. The use of direct driven generators instead of geared machines reduces the number of drive components, which offers the opportunity to reduce the number of drive components. Also it offers the opportunity to reduce the costs and increase system reliability and efficiency. For such applications, characterized by low speed is particularly situated, since it can be design with a large pole number and high torque density. The most efficient type of generators matching the above criteria is the permanent magnet generators. The permanent magnet synchronous generators are constructed in different ways. Two design characteristics of a construction type are:

- (a) The orientation of the magnetic flux within the machine.
- (b) The type of rotor construction with permanent magnets.

3.1 Longitudinal or Transversal

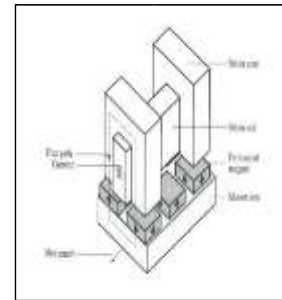

Fig-3- Longitudinal or transversal Generator

Transversal flux machines are manufactured by mounting the plane of flux path perpendicular to the direction of rotor motion. The transversal flux machines can be used in applications where high torque density requirements. The transversal flux machines can independently adjust the current loading and the magnetic loading. The main disadvantage of transverse PMSG is that high leakage flux results in poor power factor; this can be avoided by reducing the number of poles where in turn reduces torque density. Another drawback in rotating transverse PMSG is the mechanical construction is weak due to large number of parts.

3.1.2 Inner Rotor or Outer Rotor

The common rotor topology is acquired by mounting the PM's on the rotor surface. This is called a surface mounted permanent magnet rotor construction. This construction requires to shape the magnets in a circular arrangement. There are two types of rotor magnetic inner rotor and outer rotor. The outer rotor machines are constructed by placing the rotor surrounds the stator. The magnets are mounted on the inner circumference of the rotor. In the outer rotor machine, the rotor has higher radius compared with the stator and it can be equipped with higher number of poles for the same pole pitch. Another advantage is that the magnets are well supported despite the centrifugal force also, a better cooling of magnets is provided. Fig-4 shows an inner rotor PMSG and an outer rotor PMSG.

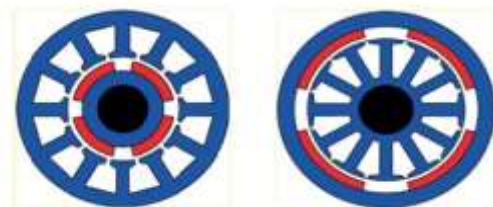

Fig-4: Inner and outer rotor

1. DESIGN AND MANUFACTURE

4.1 Structural design

The design of the dc wind turbine is simple yet unique, the structure has been made for automobiles and household installation. For structural integrity a flat aerodynamic shape had been put into use. Material use for the structure and the blades are PVC, which is durable and flexible at the same time and can withstand heavy windspeed. The components needed to build the wind turbine are shown in Fig5. While the assembly of the design is presented in Fig 6.and the fully assembled product in working condition is shown in Fig 7.



Fig-5: Components for the structure



Fig-6: Completed structure



Fig-7: Device in working condition

4.2 Circuit design

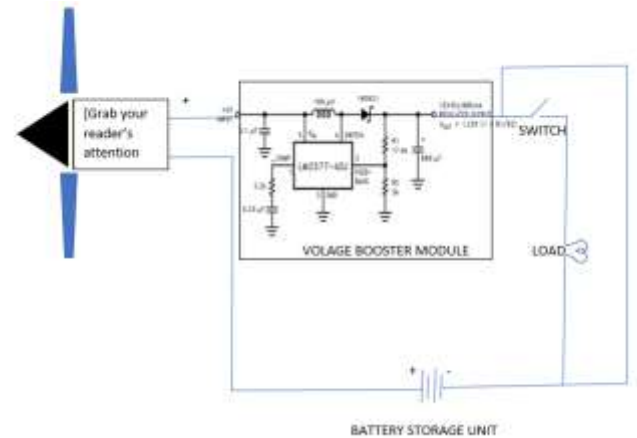

Fig-8: Circuit Design of the system

5. Results

The design of this miniature wind turbine is made to withstand the variable speed of the wind exerted if installed in a moving vehicle as well as generate optimum power up to the capacity of the wind turbine. The input voltage from the generator is fed into the booster circuit. Thus, obtaining the output voltage (step up). Thus, measuring the wind speed a maximum value of power generation is shown in the following Table Fig-8, The voltage on the circuit can be varied manually by the use of the potentiometer that is present in the circuit. Thus it is compatible for various small usage in automobiles like break lighting, indicators etc. and with greater generating capacity it can also be used for charging devices, and excess can be stored into secondary batteries.

Input voltage(V_{in})	Input current(I_{in})	Input power ($P_{in}=V_{in} \times I_{in}$)	Output voltage(V_{out})	Output current(I_{out})(A)	Output power ($P_{out}=V_{out} \times I_{out}$)
1.23	0.3	0.369	12.03	0.03	0.36
3.56	0.4	1.424	15.21	0.09	1.412
4.29	0.7	3.003	18.32	0.16	2.997
5.62	0.8	4.496	24.25	0.18	4.422
6.33	0.85	5.3805	26.42	0.20	5.32

Table-1

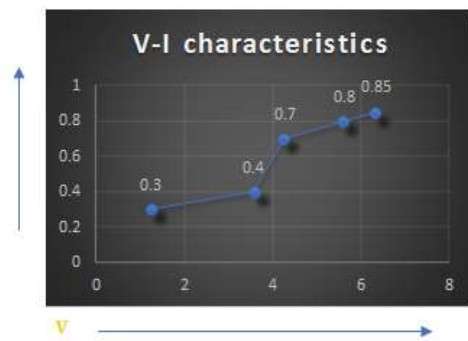

Fig -9: V-I characteristics of input power

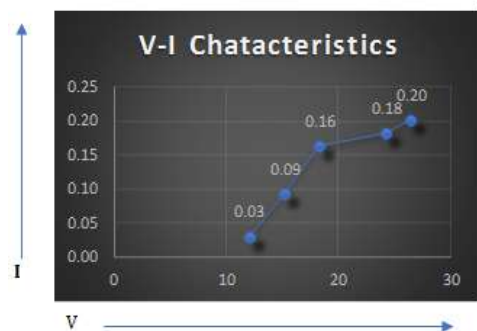

Fig -10: V-I characteristics of output power

6. CONCLUSIONS

In this work, a single phase dc motor has been implemented with a booster converter. Several outstanding features of the developed wind turbine are low input voltage, high output voltage, efficiency is remarkable, compact design, easy installation on any automobile and is targeted to low voltage application mainly for automobile and some household uses.

REFERENCES

[1]. Aerodynamic analysis and dynamic modeling of small horizontal axis wind turbine Sikandar Khan; Afzal Khan; Muhammad Irfan; Shah Hussain Robotics

[2]. Artificial Intelligence (ICRAI), 2012 International Conference on Year: 2012 Analysis and experiment research on transient behavior of flexible drive train for doubly-fed wind turbine under grid fault Shaolin Li; Ruiming Wang; Chen Chen; Yingying Wang; Wenzhuo Wang Power System Technology (POWERCON), 2014 International Conference on Year: 2014

[3] An experimental study on the effects of incoming wind conditions on wind turbine aeromechanics Wei Tian; Ahmet Ozbay; Hui Hu Fluid Machinery and Fluid Engineering, 2014 ISFMFE - 6th International Symposium on Year: 2014

[4] Development of wind turbine simulator for wind energy conversion systems based on permanent magnet synchronous motor Weihao Hu; Yue Wang; Xianwen Song;

Zhaoan Wang Electrical Machines and Systems, 2008. ICEMS 2008. International Conference on Year: 2008

[5] A new method of wind turbines modeling based on combined simulation Wang Yingying; Li Qing; Qin Shiyao Power System Technology (POWERCON), 2014 International Conference on Year: 2014

[6] Quantifying the effect of wind turbine size and technology on wind power variability Th. Boutsika; S. Santoso 2013 IEEE Power & Energy Society General Meeting Year: 2013

[7] Quantifying the effect of wind turbine size and technology on wind power variability Th. Boutsika; S. Santoso Page53

[8] The intelligent control method study of variable speed wind turbine generator Xin-yan Zhang; Jing Cheng; Wei-qing Wang [9] The Study of on Grid Wind Turbine Generator Made in China Xin-yan Zhang; Xiao-bo Zhang; Wei-qing Wang; Xin-yan Zhang; Wei-qing Wang; Suonan Jiale

[10] Mathematical toolbox and its application in the development of laboratory scale vertical axis wind turbine CV Aravind; R. Rajparthiban; R. Rajprasad; I. Grace; Rozita Teymourzadeh; M. Norhisam

[11] Analysis on and precautions against large-scale wind turbines off-grid Zifen Han; Yinli Cao; Huaisen Jia; Jiandong Wang; Liang Lu

[12] The effect of number of blades on the performance of H-Darrieus type wind turbine Agus Sunyoto; Frederikus Wenehenubun; Hadi Sutanto

BIOGRAPHY



Mr. Pallav Dutta currently working as an Assistant Professor at Narula Institute of technology. Mr Dutta has a keen interest in developing small affordable electrical equipment that can enrich our lives.