

Face Recognition Based Car Ignition and Security System

Ketan J. Bhojane¹, S. S. Thorat²

¹Electronics and Telecommunication Department, GCOE, Amravati, India

²Assistant Professor, Electronics and Telecommunication Department, GCOE, Amravati, India

Abstract - A vehicle key is the only way to start the car or to provide ignition to the engine. The face recognition based car ignition system literally replaces the car ignition by replacing the key with specific user face. While dealing with the topic the objective arises is the achievement of luxurious features and the safety concern, which can be achieved by means of the automotive electronics. In this paper, we are proposing facial recognition system by embedding face detection and face tracking system algorithm found in MATLAB with use of Raspberry pi B. The options of facial recognition and detection have been taken into consideration just because it is widely used in the interactive user interface and plays a crucial role in computer vision. There is a strong need for robust and efficient face detection algorithm

Keywords: Ignition, automotive electronics, face recognition, MATLAB, Raspberry pi B, computer vision

Introduction:

With the knowledge and applications of large amount embedded techniques, car security program study and analyses are consistently improving. Many trendy techniques, a well-known as biometric passport campaign, perception processing technique, communication technique thus, have been entire into car security systems. At the same anticipate, the approach to the cars remains valuable. So, one efficient car security program should be sensible, competent and reliable. So to prohibit vehicles stealing from thieves, owners of the automobiles are facing towards technology as an anti-robbery system.

There are heaps of anti-theft systems ready to be drawn in the complete market. However, the price camp on the doorstep of such anti-theft system is low expensive. In this business, we confirm a prototype of a real anticipates anti-theft system which can be doubtless implemented by automobile owners worldwide. This prototype uses a Microcontroller and GSM service.

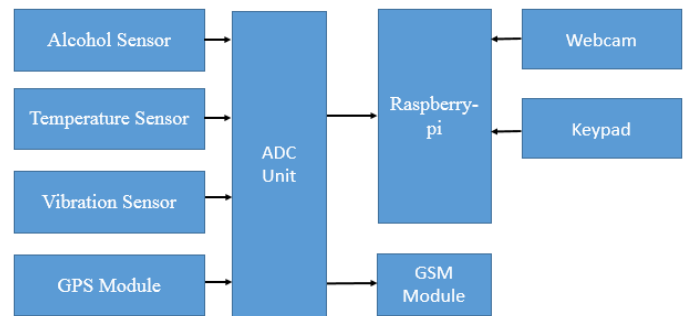

Fig. The architecture of face recognition based car ignition system.

Detecting faces in images is a fundamental task for realizing surveillance systems or intelligent vision-based human computer interaction [1]. To build flexible systems that work in a variety of lighting conditions and run on mobile phones or handheld PCs, robust and efficient face detection algorithms are required. Appearance-based methods are mainly employed to achieve high detection accuracy.

After image face recognition, which has been researched for years, the research on the video-based face detection and recognition can be considered as the continuation and extension and some good results have been reported. For example, the well-known methods such as Principal Component Analysis, Linear Discriminant Analysis, Hausdorff distance measure for face recognition, Elastic Graph Matching, eigenspace-based face recognition, a novel hybrid neural and dual eigenspaces methods for face recognition, eigenfaces, and Fisher faces methods. In order to capture the face image accurately, many face detection methods have been proposed, such as discriminating feature analysis and Support Vector Machine (SVM) classifier for face detection, face detection in color images based on the fuzzy theory, neural network-based face detection. Face color information is an important feature in the face detection. In reference, the latest survey of skin-color modeling and detection methods was presented. Statistical color modules with application to skin detection were reported in reference. For face detection, the quantized skin

color regions were given in the reference. The eye is another important feature for face detection and recognition process.

Methodology:

A typical stepwise flow for the aforementioned system is as follows:

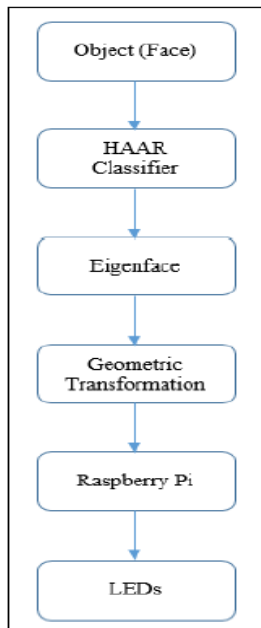

Fig.: System flow

In this paper mainly the use of Haar-like feature has been used to detect and recognize the face of the authenticated user so as to achieve the secure environment for ignition and accessing the car a typical rectangular haar-like feature can be shown as follows:

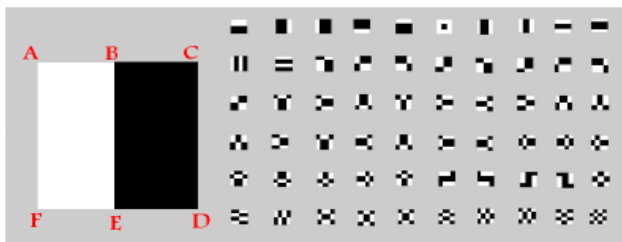

Fig.: Rectangular haar like feature

Digital Image Processing:

Digital Image Processing is the processing of images which are digital in nature by a digital computer [6]. Digital image processing techniques are motivated by three major applications mainly:

- a. Improvement of pictorial information for human perception
- b. Image processing for autonomous machine application
- c. Efficient storage and transmission.

Face Detection:

Detecting faces in images is a fundamental task for realizing surveillance systems or intelligent vision-based human computer interaction. To build exible systems that work in a variety of lighting conditions and run on mobile phones or handheld PCs, robust and efficient face detection algorithms are required. Appearance-based methods are mainly employed to achieve high detection accuracy. An improved face detection and recognition method based on information of skin color is a powerful fundamental cue of human faces. Skin color detection is first performed on the input color image to reduce the computational complexity. Morphological operations are used and it gives a prior knowledge for face detection. Face is detected by Adaboost algorithm. AdaBoost learning is used to choose a small number of weak classifiers and to combine them into a strong classifier deciding whether an image is a face or not. Then, by using principal component analysis(PCA) algorithm, a specific face can be recognized by comparing the principal components of the current face to those of the known individuals in a facial database built in advance.

Black Box:

These devices can reveal even a minor fender-bender or slight damage such scribbling, scratching, or staining. However, there are important issues such as user privacy and a data management for a vehicle-based CCTV records although car black boxes are widely installed with their significant benefits. Drivers do not want to be revealed their private information such as their position and travel route from a car black box. This concern can be reduced if CCTV records are controlled under law enforcement. In addition, we should know that the effects of car CCTV are amazing. The mass media often reports on CCTVs abilities to identify criminals. Some statistics show that violence crimes decrease by 31.5per., while robbery and theft decreased by 40per and 46.4per, respectively. Therefore, it is necessary to be broadly installed a car CCTV for public safety. The other issue is that the centralizing data management of CCTV records causes traffic overhead in wireless/wired networks and management overhead of huge video data. In the previous interworking scenarios between a car black box and wireless networks, a car sends all real-time video data recorded in its black box to a central server. In other words, real-time communications spend on enormous amount of network resources. At the server-side, the high costs of accident/crime investigation are required due to huge video data. We propose an evidence collection system using car

black boxes that can reduce privacy concerns and communication and management overheads. In this demonstration, car black boxes also play a role in CCTV for preventing some crimes. We will show how to effectively collect and manage the information obtained from car black boxes.

Results:

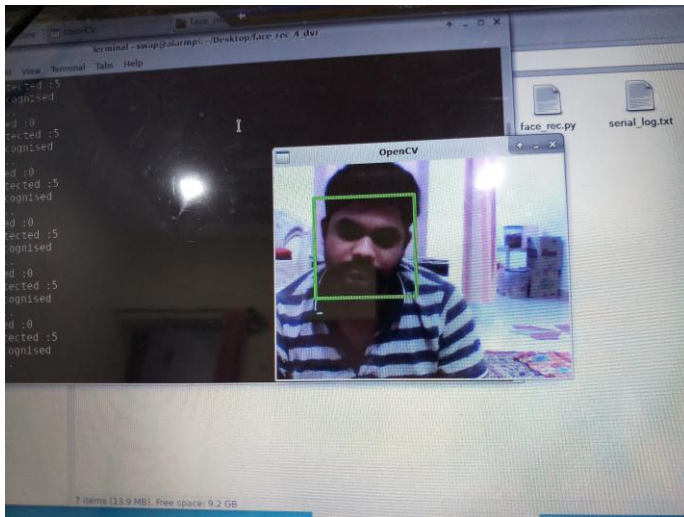

Fig. Face Detected Successfully

This framework can be effortlessly fitted in vehicles and can give exact results in All situations. With the assistance of GSM framework consolidated in the undertaking, it will caution the proprietor about the burglary furthermore the robbery picture is put away in the database for the further activities like police Confirmation. The model of the framework is as appeared as shown. (ADD IMAGE OF PROTOTYP)

When the user enter the car and sit on the driver seat facing towards front side properly. The hidden camera placed in front corner of the car interior start image acquisition and detects the face of person in a drivers seat (IMAGE OF FACE) The system has successfully implemented in the real time environment with capability to capture the object that appears in front of the camera in three seconds.

Conclusion and future scope:

From the results obtained in the demonstration it is clear the system provides faster face detection and recognition for owner authentication. Ignition is provided immediately, after owner authentication, for starting the car engine All the sensors of black box are excellent at performance and provide adequate data to the system for monitoring and accurate information about the status of car is provided to the owner and family This means that the system fulfill all the expected results and it is fruitful for the user.

As the actual implementation of the system for commercial purpose is taken in to the consideration the system can be upgraded with advance components. For improving system Performance, best and advance versions of the components used, can be included in the system Advance version refers to Orange-pi for faster processing, high resolution cameras, higher accuracy digital sensors etc.

References:

1. Winda Astuti Computer Engineering, E. Byan Wahyu Riyandwita Industrial Engineering, Bina Nusantara University, **"Intelligent automatic starting engine based on voice recognition system"**, 2016 IEEE Student Conference on Research and Development (SCOREd).
2. Ali Akbar Shah; Zulfiqar Ali Zaidi; Bhawani Shankar Chowdhry; Jawaid Daudpoto, Mehran University of Engineering and Technology Jamshoro, Pakistan, **"Real time Face Detection/Monitor using Raspberry pi and MATLAB"**, 2016 IEEE 10th International Conference on Application of Information and Communication Technology (AICT).
3. Chetan Patil, Yashwant Marathe, Kiran Amoghmath, National institute of technology karnataka, surathkal, Sumam David S, **"Low Cost Black Box for Cars"**, IEEE 2013 Texas Instruments India Educators' Conference.
4. Sayem Chaklader, Junaed Alam, Monirul Islam, Ali Shihab Sabbir Department of Computer Science & Engineering Independent University, Bangladesh, **"Black Box: An Emergency Rescue Dispatch System for Road Vehicles for Instant Notification of Road Accidents and Post Crash Analysis"** 2014 IEEE, 3rd International Conference On Informatics, Electronics & Vision.
5. Josué Aarón López Leyva, Víctor Daniel Ajás Terriquez CETYS Universidad, **"Car Black Box System (CBBS) using FPGA for determine the car orientation: preliminary results"**, IEEE 2014, International Conference on Mechatronics, Electronics and Automotive Engineering.
6. Daniel Hefenbrock, **"Accelerating Viola-Jones face detection to FPGA-level using GPUs,"** Proceedings of the 2010 IEEE, 18th Annual International Symposium on Field-Programmable Custom Computing Machines, 2010, pp.11-18.
7. Hariz Hazli Bin Aziz, Noor Hafizah Abdul Aziz and Kama Azura Othman Faculty of Electrical Engineering Universiti Teknologi MARA Malaysia, **"Mobile Phone Car Ignition System Using Embedded Blue 506 Bluetooth Technology"**,

2011 IEEE, Control and System Graduate Research Colloquium

8. Jamilah Karim, Wan Mohd Arman Bin Wan Amat, Abdul Hadi Abdul Razak Universiti Teknologi MARA (UiTM), "***Car Ignition System via Mobile Phone***", 2009 IEEE, International Conference on Future Computer and Communication