

Design and Fabrication of Staircase Sliding Lift for G+2 Existing Structures

Ismail S. Laddhani¹, Prof. M. Sohail Pervez²

¹M Tech. (MED) Student of Mechanical Engineering Department Anjuman College Of Engineering And Technology College Nagpur, Maharashtra, India

²Assistant Professor of Mechanical Engineering Department Anjuman College Of Engineering And Technology College Nagpur, Maharashtra, India.

Abstract - This present paper deals with the design and fabrication of a stair case slider/lift, which is a mechanical device for lifting people up and down on the stairs, who may find difficulty in doing so themselves. A stair case slider/lift can be used as Material Handling System too. For sufficiently wide stairs, a rail is mounted to the side wall of the stairs. A lifting platform is attached to the rail. A person on the platform is lifted as the platform moves along the rail. Stair case slider/lift is a type of lift that can be mounted on the stair case without altering civil structure. This slider runs on electric power and consists of a motor, reduction gear box, rope drive, two rails and a sliding platform. Advantages over the conventional lift are no civil structure alteration is required, low cost, less bulkiness, less power, less maintenance requires, easy design, easy installations. This slider can have industrial application too. Moreover, considering some drawbacks due to weight carrying capacity completely depend upon the capacity of motor. We chose the maximum load under consideration 1.5 KN i.e. 150 kg (Person standing and frame along with platform).

Keywords: Platform, Rails, Wire rope drive, AC motor, civil structure.

1. INTRODUCTION

A stair case slider/lift is a safe and secure method for human transportation which is a mechanical device for lifting people up and down stairs. As we know the elevators had been made a lot of developments till now elevators that we see nowadays in the markets or other places [1]. An elevator or lift is vertical transport equipment that efficiently moves people or goods between floors (levels) of a building, or of other structure [2]. Elevators are generally powered by electric motors that either drive traction cables or counterweight systems like a hoist or pump hydraulic fluid to raise a cylindrical piston like a jack. Because of wheelchair access laws, elevators are often a legal requirement in new multi-storey buildings, especially where wheelchair ramps would be impractical. Sometime the elevator needs extra depth underground for installing and especially in the multi storied buildings. In case lift to be installed in the stalk structure then alteration cost will be appreciably high.

The urbanization started some 2 to 3 decades ago and has taken much of the City limits to get compressed nearest to the amenities which resulted in high rise. Most residential buildings were granted the permission to build up to Ground plus 2 or 3 storied, wherein Elevator was not installed. Since at that time, it was not considered necessary and people preferred to climb stairs, irrespective of all odds. Consequent to the Life-Style changes, including physical and mental apathy, currently the four storey building residents have started to feel the need for having a Elevator in their buildings. But now many factors abide them such as local body governing rules for town planning, constructional requirement and cost of installation of the Elevator [3].

To overcome all these factors and to avoid civil construction/alteration cost the concept of stair case slider/lift comes with being which reduced extra costing associated with the lift mechanism, the benchmark of the system is that this concept is associated with simplifying as well. Some people argue that lifts began as simple rope or chain hoist. A lift is essentially a platform that is either pulled or pushed up by a mechanical means.

For sufficiently wide stairs, a rail is mounted to the side wall of the stairs. A lifting platform is attached to the rail; a person standing on the platform is lifted as the platform moves along the rail. Staircase slider is also known variously as stair-lifts, chair lifts, stair gliders and by other names. This slider of course runs on electric power and consists of a motor, two rails and sliding platform. This stair case slider can be mounted on stock stair case where the civil structure is not be altered ; and still handicapped or old age or people with incapability to raise by themselves are to be carried across the stair case.

In the old buildings that do not have elevators or consist of two floors or more must have a device for transportation as we mentioned before. So we made a research to fill this space which is becoming need of the time, because it is easy to install, economic and does not require high maintenance.

2. DESIGN AND CALCULATIONS

Length, L = 3.5 m

2.1 Data accumulation

2.1.1 Stair Case Measurement

Pitch line from Horizontal surface = 28°
 Pitch length = 3617.214 mm
 Tread depth = 290.068 mm (including nose)
 Rise height = 152.4 mm (including tread width)
 Rise = 1856.7908 mm
 Run = 3190.748 mm
 Distance to be covered by slider = 3505.2 mm on pitch line

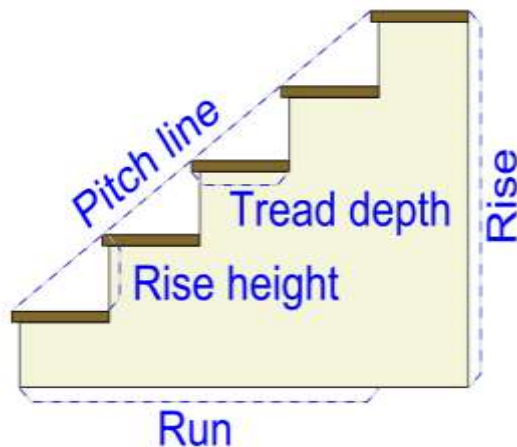

Fig-1: Stair Case Measurement

2.1.2 Load to be carried

Weight to be lifted = (130+20) kg (Passenger travelling over slider plus frame and platform weight)

$$= 150 * 9.81 = 1471.5$$

Approximately 1475 N / 1.5 KN

Design: Standard tables referred from design data book B.D. Shiwalkar [4]

2.2 Components

- i. Wire rope
- ii. Mini rope hoist
- iii. Frame and platform
- iv. C-Channel

2.3 Wire rope

Usage load which includes the weight of platform and person to be lifted,

$$W_u = (130 + 20) \text{ kg} * 9.81$$

$$= 1471.5 \text{ N} / 1.4715 \text{ KN} = 1.5 \text{ KN (approx.)}$$

Step 1.

- a. Select suitable type of wire rope for given application

6*19 Wire rope
 [T-IX-3]

- b. Select suitable factor of safety for given application

For small electric and air hoist

Factor of safety, N = 7

[T-IX-5]

Step 2.

Now calculate breaking strength, F_{ut}

$$N = \frac{F_{ut}}{2 * W_u}$$

$$7 = \frac{F_{ut}}{2 * 1.5}$$

$$F_{ut} = 21 \text{ KN}$$

Step 3.

Calculate all the dimensions of wire rope and other essential parameters

[T-IX-3 and T-IX-7]

Table-1: Wire Rope Dimensions And Other Parameters

PARAMETER	SYMBOL	FORMULA E	VALUE
Minimum rope diameter	$D_{r \min}$	$\sqrt{\frac{F_{ut}}{1.20}}$	4.18 mm
Rope diameter selected {std}	D_r		6 mm
Weight of rope	W_r	$37 D_r^2 * 10^{-3}$ and $wt/m * L$	1.332 N/m and 4.662 N
Wire diameter	d_w	$0.063 D_r$	0.378 mm
Cross sectional area of metal	A	$0.38 D_r^2$	13.68 mm ²
Drum size	D_s	$45 D_r$	270 mm
Bending load	F_b	$84 * 10^{-3} *$	1.608

		$A * \frac{dw}{ds}$	KN
Accelerating load	F_a	$\left(\frac{W_u + W_r}{g}\right) \left(\frac{v-u}{t}\right)$ or m * a	$2.129 * 10^{-4}$
Starting load	F_{st}	$2 (W_u + W_r)$ {no slack h=0}	3.0093 KN

Step 4.

Factor of safety

a) Starting phase

$$N_1 = \frac{F_{ut}}{F_{st} + F_b} = \frac{3.0093 + 1.608}{2.1} = 4.548$$

b) Accelerating phase

$$N_2 = \frac{F_{ut}}{F_{st} + W_r + F_a + F_b} = \frac{3.0093 + 4.662 * 10^{-3} + 2.129 * 10^{-3} + 1.608}{2.1} = 4.541$$

c) Uniform velocity phase

$$N_3 = \frac{F_{ut}}{W_u + W_r + F_b} = \frac{1.5 + 4.662 * 10^{-3} + 1.608}{2.1} = 6.747$$

Step 5.

Now checking conditions

a. $N_1 > \frac{N}{2}$
 $4.548 > 7/2$
 $4.547 > 3.5$

Step 6 . Drum proportions

The dimensions of drum from the empirical relation can be directly written as

[T-IX-8]

Table-2: Drum Proportions

PARAMETER	SYMBOL	FORMULAE	VALUE
Radius of wounding gap	r	$0.53 D_r$	3.18 mm
Pitch	p	$1.15 D_r$	6.9 mm
Depth of Groove	t_1	$0.25 D_r$	1.5 mm

2.4 Mini rope hoist

Motor specifications required as per design calculations

Table-3: Specifications Required

PARAMETER	VALUES
Weight to be lifted	150 kg
Distance to be covered	3.5 meters
Speed	4 -5 m/min
Rope diameter	6 mm
Rope length	Min 10 meters

From market survey, we have found all in one pack Mini wire rope hoist which meets our design requirement

Table-4: Specification Table of Mini Wire Rope Hoist

Model name- PA500	
PARAMETER	VALUES
Wire rope diameter	6 mm
Wire rope length	20 meters
Motor	1020 W / 1.37 hp {1 W = 0.00134 hp}
Weight carrying capacity	400-500 Kg
Speed	5 m/min

Note:

Time required by slider to reach rise height

Speed 5m/min and Distance 3.5 m

\square time = $(3.5 \times 60) / 5 = 42$ seconds

2.5 Trolley: Frame and Platform

During the working of frame, a majority of its structures are subjected to compound loading and their resultant deformation consists of bending, tension and compression. Under simple tensile or compressive loading, the strength and stiffness of an element depend only upon the area of cross section [5].

However, the deformation and stresses in elements subjected to bending, additionally, upon the shape of the cross section. A certain volume of metal can be distributed in different ways to give different values of the moment of inertia and sectional modulus. The shape that provides the maximum moment of inertia and sectional modulus will be considered best as it will ensure minimum values of stresses and deformation [5].

2.5.1 Frame:

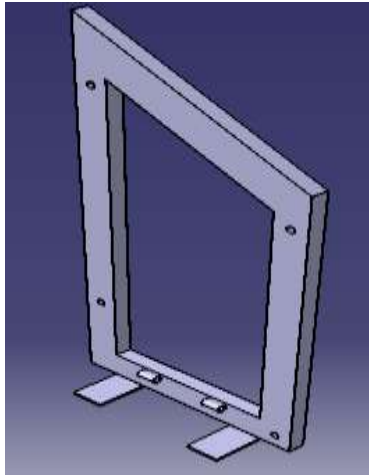

Fig-2: Frame

Frame is fabricated with MS rectangle pipe of 50.8 mm x 25.4 mm cross section and thickness of 1.2 mm (16 gauge).

Dimensions:

Base side 355.6 mm

Left side support 762 mm

Right side support 558.8 mm

Slant side 406.4 mm

2.5.2 Platform:

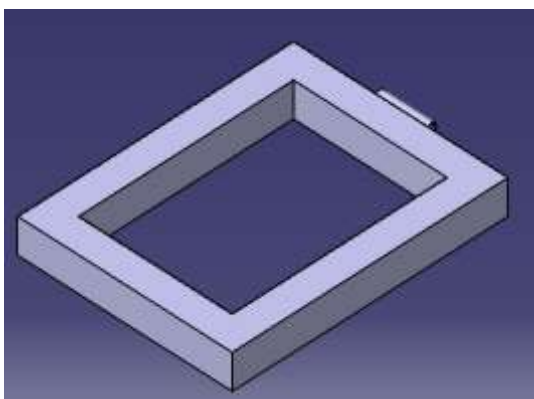

Fig-3: Platform

From ergonomic consideration we have selected width of platform as 355.6 mm and length of 457.2 mm.

Platform is fabricated with MS square pipe of 50.8 mm x 50.8 mm cross section and thickness of 1.5 mm (14 gauge).

Dimensions: Width 355.6 mm

Length 457.2 mm

Centre of gravity of whole frame and platform assembly is 175.494 mm.

2.6 C- channel:



Fig-4: C-Channel

Dimensions:

Thickness at height tip 3.5 mm

Thickness at height tip 5 mm

Width 70 mm

Height 35 mm

3. CAD Design , Analysis and Fabrication

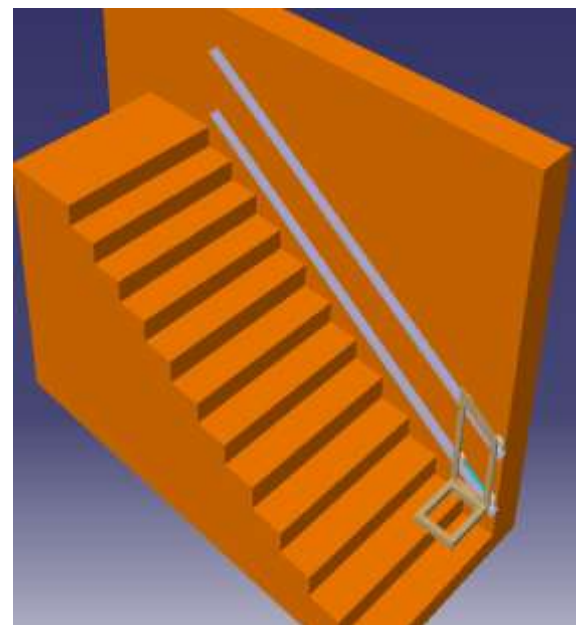

Fig-5: Complete Assembly Cad Image

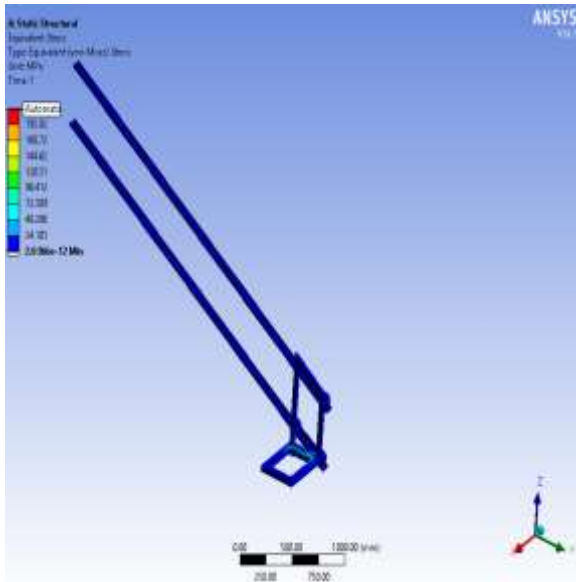

Fig-6: Full model Max. Vonmises stress=192.82 N/mm²

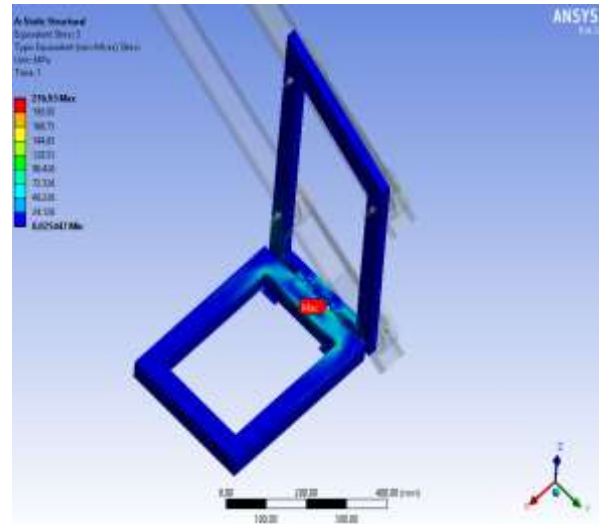

Fig-9: Frame Stress Max. = 216.93 N/mm²

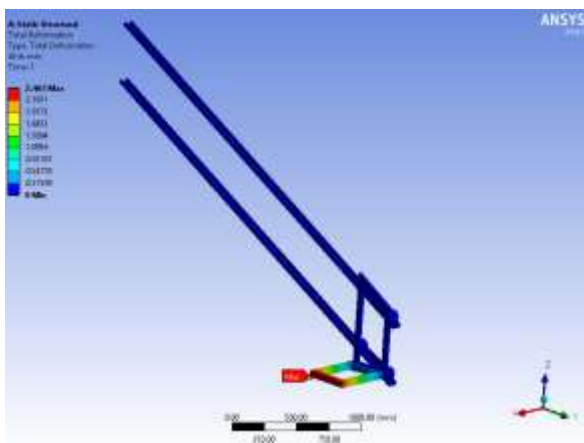

Fig-7: Full Model Deformation Max. = 2.465 mm

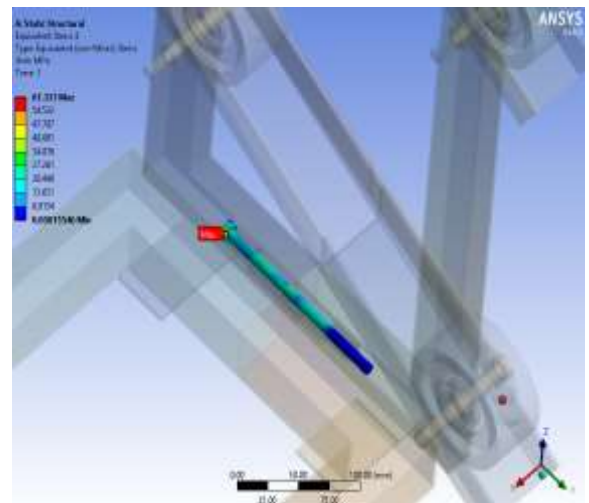

Fig-10: Hinged connecting bolt Max. Vonmises stress=61.337 N/mm²

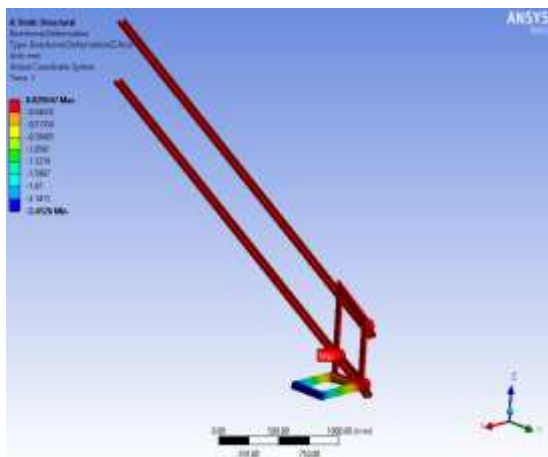

Fig-8: Full Model Deformation in Z direction Max. = 0.02904 mm (channel fixed along wall)

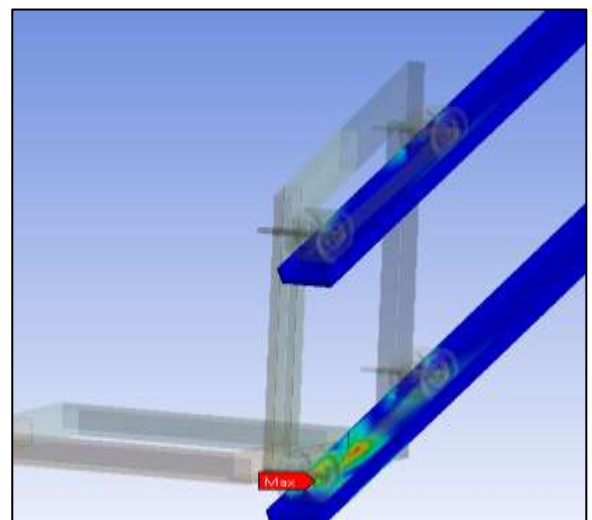

Fig-11: C-Channel Max. Vonmises stress= 43.516 N/mm² (magnified image)



Fig-12: Fabrication Image

4. Result

We analyzed the stress and deformation for full model and corresponding parts with the help of ANSYS. For full model 1000 N of load was applied over the cg of passenger travelling and it was found that maximum equivalent vonmises stress is 216.93 N/mm², and deformation is 2.465 mm. This lies within the permissible limits.

5. Installations and Safety features

5.1 Four wheel balancing

According to the width of standing platform wheels are placed linearly on the frame. As the pitch line of the stairs is at 28°, rails gauge channels are placed parallel to the pitch line of the stairs and correspondingly wheels are calibrated to the channel slope, it provides vibration free/shock free travel over.

5.2 Emergency start/stop switch

Emergency start/stop switch is placed over the toggle/push button control remote which operates the motion of the slider. As the feature name is self expressing, in case of emergency passenger can shut of the motor operation and safely land over the tread landing of the stairs.

5.3 Waist belt

As this concept is established for person with lack of mobility an add on safety feature is provided i.e. waist locking support belt.

5.4 Handle for firm grip

To assure a stable and safe travel, handle (reversible for downward travel) is attached over main frame. And it has given detachment

arrangement, if in case someone doesn't find need for handle support.

6. CONCLUSION

Stair case slider can be adapted for its sheer use simplicity and economy. During the test run of this project, it was realized that it would be capable of carrying heavy load without suffering any deformation or local fractures if it would go into real world production at an ideal scale. Therefore it can be widely used for home as well as industrial purpose which ensures a promising future to the concept. In context to market the economical aspect of this system proves to be very sound and the typical Indian context would always insist upon economy without compromising quality & multi utility.

REFERENCE

1. Timur Choban Khidir, Abbas Mohammed Ismael & Ayaz Aydin Abduljabbar "designing and analysing stair case lift system" 2017 European Journal of Engineering and Technology Vol. 5, No. 4, ISSN 2056-5860
2. Gaikwad Avinash & Bhalerao Sachin "Design and Finite Element Analysis of a Stair Case Material Handling System" IJSER, ISSN (Online): 2347-3878, Volume 1, Issue 1, September 2013
3. Ismail S. Laddhani & Prof. M. Sohail Pervez "Literature Review for Staircase Slider Mechanism for Person with Lack of Mobility" 2018 IJSRST Volume 4, Issue 3, Print ISSN : 2395-6011, Online ISSN: 2395-602X
4. Design data for machine elements by B.D Shiwalkar Published by Denett & Co.
5. Machine tool design and numerical control by N.K Mehta Published by McGraw Hill education Pvt Ltd.
6. Kheir Al-Kodmany "Tall Buildings and Elevators: A Review of Recent Technological Advances 'MDPI Journals buildings ISSN 20755309 Published: 17 September 2015
7. K. Paetzold, S. Wartzack and D. Krause 'Platform of Design Method for developing mobility preserving products' ELSEVIER CIRP 21 (2014)409-41.