

APPLICATION OF TAGUCHI METHOD FOR OPTIMIZATION OF PROCESS PARAMETERS IN SPUR GEAR MILLING OPERATION

Sudeesh S¹, Jyothish Warriar², Kiran Joy², Sajul U⁴, Sreeprasanth M⁵

¹Assistant Professor, Dept. of Mechanical Engineering, Ammini college of Engineering, Kerala, India

^{2,3,4,5} B.Tech Scholar, Dept. of Mechanical Engineering, Ammini college of Engineering, Kerala, India

Abstract - Taguchi method is a statistical approach for optimizing design process developed by Genichi Taguchi. This method is also known as robust design methods. Optimizing a process is about finding optimum factor levels for peak performance. It gives a design or process which will not only stay within specifications but also be centred at the target. A spur gear milling operation is carried out in a vertical milling machine. Taguchi method is applied to this process by considering the spindle speed, depth of cut and feed rate as the process parameters. An orthogonal array, signal-to-noise ratio, analysis of variance (ANOVA) are employed to analyse the effect of these milling parameters. The results obtained are used to determine the optimum combination of process parameters for low resultant cutting force and good surface finish.

Key Words: Milling, Spur gear, Optimization, Taguchi, S/N ratio, ANOVA.

1. INTRODUCTION

Taguchi method is a statistical method developed by Genichi Taguchi. Initially it was developed for improving the quality of goods manufactured (manufacturing process development), later its application was expanded to many other fields in Engineering, such as Biotechnology etc. Success in achieving the desired results involves a careful selection of process parameters and classifying them into control and noise factors. Selection of control factors must be made such that it nullifies the effect of noise factors. Taguchi Method involves identification of proper control factors to obtain the optimum results of the process. Orthogonal Arrays (OA) are used to conduct a set of experiments. Results of these experiments are used to analyse the data and predict the quality of components produced. Robust design is an engineering methodology for obtaining product and process conditions, which are minimally sensitive to the various causes of variation to produce high quality products with low development and manufacturing costs. Taguchi's parameter design is an important tool for robust design. It offers a simple and systematic approach to optimize design for performance, quality and cost.

Two major tools used in robust design are:

- signal to noise ratio, which measures quality with emphasis on variation
- Orthogonal arrays, which accommodate many design factors simultaneously.

When a critical quality characteristic deviates from the target value, it causes a loss. Continuously pursuing variability reduction from the target value in critical quality characteristics is the key to achieve high quality and reduce cost. This project deals with the application of Taguchi method for the analysis of process parameters in spur gear milling operation and thereby obtaining a combination of process parameters for optimum surface finish and low resultant cutting force. The influence of cutting parameters, i.e speed, feed and depth of cut on the surface finish and cutting force are analysed.

2. LITERATURE SURVEY

S.Shaji, V.Radhakrishnan have conducted a newer cooling method for grinding operation [1]. Conventionally, liquid coolants in flood form are employed in grinding. However, there has been an afterthought in the usage of fluid in this way on some technical, environmental and economic grounds. This paper deals with the analysis of the process parameters such as speed, feed, infeed and mode of dressing as influential factors, on the force components and surface finish developed based on Taguchi's experimental design methods. Taguchi's tools such as orthogonal array, signal-to-noise ratio, factor effect analysis, ANOVA, etc. have been used for this purpose and an optimal condition has been found out. The results have been compared with the results obtained in the conventional coolant grinding. This paper deals with analysis of process parameters, such as speed, feed, infeed, mode of dressing of grinding process. The surface finish and force components are determined by S/N ratio, ANOVA etc. Introduces newer cooling technique - graphite paste. We have obtained a detailed understanding of applying Taguchi method by referring to this journal.

J.A. Ghani, I.A. Choudhury, H.H. Hassan [2] applied the Taguchi optimization methodology, to optimize cutting parameters in end milling when machining hardened steel

AISI H13 with Ti N coated P10 carbide insert tool under semi-finishing and finishing conditions of high speed cutting. The parameters found in this experiment are cutting speed,

Feed rate and depth of cut. The Taguchi method is suitable to solve the stated problem with minimum number of trials as compared with a full factorial design. An orthogonal array, signal-to-noise (S/N) ratio and ANOVA are employed to analyse the effect of these milling parameters. The paper describes a case study on end

milling parameters at three levels each. The average S/N ratios for smaller the better for surface roughness and resultant force factors and significant interaction. Study of cutting speed and interaction between feed rate and depth of cut are more significant. The highest cutting speed appears to be the best choice to get low value of surface finish, and thus making the process robust to the cutting speed in particular.

- The cutting speed has found to be the most significant effect to produce low value of average surface roughness (R_a). Due to the velocity of chips that is faster at high cutting speed than at low cutting speed.
- A good surface finish is obtained. The surface roughness produced in milling operation depends on feed rate, and the tool angular position depends on the depth of cut and radius of the cutter.
- The use of S/N ratio for selecting the best levels of combination for surface roughness (R_a) value suggests the use of low value of feed rate in order to obtain good finish. Smaller angle of tool angular position is obtained at lower depth of cut. Therefore, it is preferable to set the depth of cut to a low value.
- The combination of feed rate and depth of cut determines the undeformed chip section and hence the amount of energy required to remove a specified volume of material. The required force to form the chips is dependent on the shear yield strength of the work material under cutting conditions and on the area of the chip section and the shear zone.
- In the end milling, use of high cutting speed low feed rate and low depth of cut are recommended. Low feed rate low depth of cut lead to smaller value of resultant cutting force the specific test range. The end milling experiment shows that the use of high cutting speed, low feed rate and low depth of cut leads to better surface finish and low cutting force.

M.Nalbant, H.Göçkaya, G. Sur[3] applied Taguchi method to find the optimal cutting parameters for surface roughness in turning. The orthogonal array, the signal-to-noise ratio, and analysis of variance are employed to study the performance characteristics in turning operations of AISI 1030 steel bars using TiN coated tools. Three cutting parameters namely, insert radius, feed rate, and depth of cut, are optimized with considerations of surface roughness. Experimental results are provided to illustrate the effectiveness of this approach. In this study, an approach based on the Taguchi method is used to determine the desired cutting parameters more efficiency. This paper has presented an application of the parameter design of the Taguchi method in the optimization of turning operations.

The following conclusions can be drawn based on the experimental results of this study:

- Taguchi's robust orthogonal array design method is suitable to analyse the surface roughness (metal cutting) problem as described in this paper.
- It is found that the parameter design of the Taguchi method provides a simple, systematic, and efficient methodology for the optimization of the cutting parameters.
- Surface roughness can be improved simultaneously through this approach instead of using engineering judgement. The confirmation experiments were conducted to verify the optimal cutting parameters.
- The improvement of surface roughness from initial cutting parameters to the optimal cutting parameters is about 335%.
- Deviations between actual and predicted S/N ratio of surface roughness are small each parameter.

From referring to this study we were able to effectively understand that surface roughness can be improved significantly to an optimum value without sacrificing the optimum cutting parameters. A general idea about the value of surface finish to be obtained in a machining process is deduced by referring this paper. The level of experiments to be conducted and the concept relating to control factors and noise factors are clearly understood from this study.

Pratyusha, Ashok kumar, Laxminarayan [4] did the work which deals with the effects of various milling parameters such as spindle speed, feed rate, and depth of cut on the surface roughness of finished components. The experiments were conducted on AISI 304 S.S plate material on vertical milling machine using carbide inserts and by using Taguchi's technique including L9 orthogonal array. The analysis of mean and variance technique is employed to study the significance of each machining parameter on the surface roughness. The experiments have been planned using Taguchi's experimental design technique. The machining parameters used are Depth of cut (d_c), Spindle speed (N), and Feed rate (f). The effect of machining parameters on surface roughness is evaluated and the optimum cutting condition for minimizing the surface roughness is determined. The predicted values are confirmed by using validation experiments. A L9 orthogonal array, Taguchi method and analysis of variance (ANOVA) are used to formulate the experimental layout, to analyses the effect of each parameter on the machining characteristics and to predict the optimal choice for each milling parameter such as spindle speed, feed rate and depth of cut. Analysed the effect of this parameter surface roughness. Results obtained by Taguchi method match with ANOVA and cutting speed are highly influencing

parameter. The analysis of the Taguchi method reveals, that in general the spindle speed significantly affects the surface roughness. From this study we were able to understand the following results:

- Taguchi method has been successfully employed for optimizing the process parameters of Milling of mild steel plates. It has been shown that the Taguchi method provides a systematic and efficient methodology for searching the milling process parameters with optimal milling parameters.
- Taguchi's Method of parameter design can be performed with lesser number of experimentations.
- As per L9 orthogonal array, we have 27 combinations. Instead of 27 experiments, nine numbers of trials were conducted.
- It is found that the parameter design of the Taguchi method provides a simple, systematic, and efficient methodology for optimizing the process parameters
- The optimum values of surface roughness, combinations of parameters and their levels are also predicted by Taguchi method. Taguchi's method can be applied for analysing any other kind of problems as described in this paper.

Srinivas Athreya, Dr, Y D Venkatesh [5] did study on with optimization of facing operation. Taguchi method is a statistical approach to optimize the process parameters and improve the quality of components that are manufactures. The objective of this study is to illustrate the procedure adopted in using Taguchi Method to a lathe facing operation. The orthogonal array, signal to noise ratio, and the analysis of variance are employed to study the performance characteristics on facing operation. In this analysis, three factors namely speed, feed, depth of cut are considered. Accordingly, a suitable array was selected and experiments are conducted. After conducting the experiments, the surface roughness was measured and signal to noise ratio was calculated. With the help of graphs, optimum parameter values were obtained and the confirmation experiments were carried out. These results were compared with the results of full factorial method. This paper illustrates the application of the parameter design in the optimization of facing operation. The following conclusions can be drawn based on the above experimental results of this study:

- Taguchi's Method of parameter design can be performed with lesser number of experimentations as compared to that of full factorial analysis and yields similar results. Taguchi's Method can be applied for analysing any other kind of problems as described in this paper.
- It is found that the parameter design of the Taguchi method provides a simple, systematic, and efficient

methodology for optimizing the process parameters.

From this study we have realised that the surface finish, the contribution of cutting speed is more significant than depth of cut. These factors are most significant than the feed rate. It is clear that the effect of noise factor on surface finish is very low as compared to the control factors.

M. Aravind and Dr. S. Periyaswamy [6] applied Taguchi method and Response Surface Methodology (RSM) in the process parameters: grinding wheel abrasive grain size, depth of cut and feed. An AISI 1035 steel square rod of 100 mm x 10 mm x 10 mm was considered for grinding. The output response was selected as Surface roughness (Ra and Rz). In Taguchi method, L27 orthogonal array was selected and S/N ratios were analysed to study the surface roughness characteristics. In response surface methodology, Box-Behnken method was used for optimization. Thirteen experiments were conducted in the surface grinding machine. The surface roughness values were entered in the Design Expert software and the optimal solution was obtained. Both methods showed that wheel grain size and depth of cut influences the surface roughness a lot. Feed of the surface grinding has a very minimal effect on the surface roughness value. This study showed that when the input parameters can be varied within the selected levels, Response surface methodology has an edge over Taguchi method. The confirmation experiments were conducted both for the optimal solution obtained from Taguchi and Response surface methodology.

From the study, the following conclusions can be made:

- Statistically designed experiments based on Taguchi methods were performed using L27 orthogonal arrays to analyse the surface roughness as response variable. Conceptual S/N ratio and ANOVA approaches for data analysis drew similar conclusions.
- The minimum surface roughness (Ra) was obtained at grain size of 60 mesh, depth of cut of 0.05 mm, feed of 0.2 mm. For Rz, the optimum parameters were grain size of 60 mesh, depth of cut of 0.05 mm and feed of 0.5 mm obtained from Taguchi Method.
- Box Behnken designed experiments based on Response Surface methodology was done, with the surface roughness as the output response variable. ANOVA and 3D response plots were also analysed.
- The minimum surface roughness (Ra and Rz) were obtained at grain size of 54 mesh, depth of cut of 0.05 mm and feed of 0.45 mm by RSM.
- This study showed that when the input parameters can be varied within the selected levels, Response

surface methodology has an edge over Taguchi method.

W.H. Yang, Y.S. Tarn [8], used Taguchi method to find the optimal cutting parameters for turning operations. An orthogonal array, the signal-to-noise (S/N) ratio, and the analysis of variance (ANOVA) are employed to investigate the cutting characteristics of S45C steel bars using tungsten carbide cutting tools. Through this study, not only can the optimal cutting parameters for turning operations be obtained, but also the main cutting parameters that affect the cutting performance in turning operations can be found. Experimental results are provided to confirm the effectiveness of this approach. Taguchi method provides a systematic and efficient methodology for the design optimization of the cutting parameters with far less effect than would be required for most optimization techniques. It has been shown that tool life and surface roughness can be improved significantly for turning operations. The confirmation experiments were conducted to verify the optimal cutting parameters. The improvement of tool life and surface roughness from the initial cutting parameters to the optimal cutting parameters is about 250%.

3. OPTIMIZATION TECHNIQUES

Many methods have been developed and implemented over the years to optimize the manufacturing processes. Some of the widely used approaches are as given below:

3.1. Build-Test-Fix:

The "Build-test-fix" is the most primitive approach which is rather inaccurate as the process is carried out according to the resources available, instead of trying to optimize it. In this method the process/product is tested and reworked each time till the results are acceptable.

3.2. One Factor at a Time:

The "one-factor-at-a-time" (OFAT) approach is aimed at optimizing the process by running an experiment at one particular condition and repeating the experiment by changing any other one factor till the effect of all factors are recorded and analysed. Evidently, it is a very time consuming and expensive approach. In this process, interactions between factors are not taken in to account. There exist cases where the mental effort required to conduct a complex multi-factor analysis exceeds the effort required to acquire extra data, in which case OFAT might make sense. Furthermore, some researchers have shown that OFAT can be more effective than fractional factorials under certain conditions (number of runs is limited, primary goal is to attain improvements in the system, and experimental error is not large compared to factor effects, which must be additive and independent of each other)

Reasons for disfavoured OFAT include:

1. OFAT requires more runs for the same precision in effect estimation
2. OFAT cannot estimate interactions
3. OFAT can miss optimal settings of factors

Designed experiments remain nearly always preferred to OFAT with many types and methods available, in addition to fractional factorials which, though usually requiring more runs than OFAT, do address the three concerns above.

3.3. Regression:

Statistical method to determine the quantified relation between responses and factors using the available data. Applied in case experimentations are ruled out due to time/cost concerns or the nature of process where experimentations are impractical. Regression analysis is widely used for prediction and forecasting, where its use has substantial overlap with the field of machine learning. Regression analysis is widely used for prediction and forecasting, where its use has substantial overlap with the field of machine learning. Regression analysis is also used to understand which among the independent variables are related to the dependent variable, and to explore the forms of these relationships. In restricted circumstances, regression analysis can be used to infer causal relationships between the independent and dependent variables. However, this can lead to illusions or false relationships, so caution is advisable. Many techniques for carrying out regression analysis have been developed. Familiar methods such as linear regression and ordinary least squares regression are parametric, in that the regression function is defined in terms of a finite number of unknown parameters that are estimated from the data. Nonparametric regression refers to techniques that allow the regression function to lie in a specified set of functions, which may be infinite-dimensional. The performance of regression analysis methods in practice depends on the form of the data generating process, and how it relates to the regression approach being used. Since the true form of the data-generating process is generally not known, regression analysis often depends to some extent on making assumptions about this process. These assumptions are sometimes testable if a sufficient quantity of data is available. Regression models for prediction are often useful even when the assumptions are moderately violated, although they may not perform optimally. However, in many applications, especially with small effects or questions of causality based on observational data, regression methods can give misleading results. Once a regression model has been constructed, it may be important to confirm the goodness of fit of the model and the statistical significance of the estimated parameters. Commonly used checks of goodness of fit include the R-squared, analyses of the pattern of residuals and

hypothesis testing. Statistical significance can be checked by an F-test of the overall fit, followed by t-tests of individual parameters.

Interpretations of these diagnostic tests rest heavily on the model assumptions. Although examination of the residuals can be used to invalidate a model, the results of a t-test or F-test are sometimes more difficult to interpret if the model's assumptions are violated. For example, if the error term does not have a normal distribution, in small samples the estimated parameters will not follow normal distributions and complicate inference. With relatively large samples, however, a central limit theorem can be invoked such that hypothesis testing may proceed using asymptotic approximations.

3.4. Design of Experiments:

The Design of Experiments is considered as one of the most comprehensive approach in product/process developments. It is a statistical approach that attempts to provide a predictive knowledge of a complex, multi-variable process with few trials. Following are the major approaches to DOE:

3.4.1. Full Factorial Design:

A full factorial experiment is an experiment whose design consists of two or more factors, each with a discrete possible level and whose experimental units take all possible combinations of all those levels across all such factors. Such an experiment allows studying the effect of each factor on the response variable, as well as on the effects of interactions between factors on the response variable. A common experimental design is the one with all input factors set at two levels each. If there are k factors each at 2 levels; a full factorial design has 2^k runs. Thus for 6 factors at two levels it would take 64 trial runs. In statistics, a full factorial experiment is an experiment whose design consists of two or more factors, each with discrete possible values or "levels", and whose experimental units take on all possible combinations of these levels across all such factors. A full factorial design may also be called a fully crossed design. Such an experiment allows the investigator to study the effect of each factor on the response variable, as well as the effects of interactions between factors on the response variable. For the vast majority of factorial experiments, each factor has only two levels. For example, with two factors each taking two levels, a factorial experiment would have four treatment combinations in total, and is usually called a 2×2 factorial design.

If the number of combinations in a full factorial design is too high to be logistically feasible, a fractional factorial design may be done, in which some of the possible combinations (usually at least half) are omitted. Many experiments examine the effect of only a single factor or variable. Compared to such one-factor-at-a-time

(OFAT) experiments, factorial experiments offer several advantages.

Factorial designs are more efficient than OFAT experiments. They provide more information at similar or lower cost. They can find optimal conditions faster than OFAT experiments. Factorial designs allow additional factors to be examined at no additional cost. When the effect of one factor is different for different levels of another factor, it cannot be detected by an OFAT experiment design. Factorial designs are required to detect such interactions. Use of OFAT when interactions are present can lead to serious misunderstanding of how the response changes with the factors. Factorial designs allow the effects of a factor to be estimated at several levels of the other factors, yielding conclusions that are valid over a range of experimental conditions. A factorial experiment can be analysed using ANOVA or regression analysis. It is relatively easy to estimate the main effect for a factor. To compute the main effect of a factor "A", subtract the average response of all experimental runs for which A was at its low (or first) level from the average response of all experimental runs for which A was at its high (or second) level. Other useful exploratory analysis tools for factorial experiments include main effects plots, interaction plots, Pareto plots, and a normal probability plot of the estimated effects. When the factors are continuous, two-level factorial designs assume that the effects are linear. If a quadratic effect is expected for a factor, a more complicated experiment should be used, such as a central composite design. Optimization of factors that could have quadratic effects is the primary goal of response surface methodology.

3.4.2. Taguchi Method:

The Full Factorial Design requires a large number of experiments to be carried out as stated above. It becomes laborious and complex, if the number of factors increase. To overcome this problem Taguchi suggested a specially designed method called the use of orthogonal array to study the entire parameter space with lesser number of experiments to be conducted. Taguchi thus, recommends the use of the loss function to measure the performance characteristics that are deviating from the desired target value. The value of this loss function is further transformed into signal-to-noise (S/N) ratio. Usually, there are three categories of the performance characteristics to analyse the S/N ratio. The philosophy of Taguchi is roadly applicable. He proposed that engineering optimization of a process or product should be carried out in a three-step approach, i.e., system design, parameter design, and tolerance design. In system design, the engineer applies scientific and engineering knowledge to produce a basic functional prototype design, this design including the product design stage and the process design stage. In the product design stage, the selection of materials, components, tentative product parameter values, etc., are involved. As to the process design stage,

the analysis of processing sequences, the selections of production equipment, tentative process parameter values, etc., are involved. Since system design is an initial functional design, it may be far from optimum in terms of quality and cost. The objective of the parameter design is to optimize the settings of the process parameter values for improving performance characteristics and to identify the product parameter values under the optimal process parameter values. In addition, it is expected that the optimal process parameter values obtained from the parameter design are insensitive to the variation of environmental conditions and other noise factors. Therefore, the parameter design is the key step in the Taguchi method to achieving high quality without increasing the cost. Basically, classical parameter design, developed by Fisher, is complex and not easy to use. Especially, a large number of experiments have to be carried out when the number of the process parameters increases. To solve this task, the Taguchi method uses a special design of orthogonal arrays to study the entire parameter space with a small number of experiments only. A loss function is then defined to calculate the deviation between the experimental value and the desired value. Taguchi recommends the use of the loss function to measure the performance characteristic deviating from the desired value. The value of the loss function is further transformed into a signal-to-noise (S/N) ratio. Usually, there are three categories of the performance characteristic in the analysis of the S/N ratio, that is, the lower-the-better, the higher-the-better, and the nominal-the-better. The S/N ratio for each level of process parameters is computed based on the S/N analysis. Regardless of the category of the performance characteristic, the larger S/N ratio corresponds to the better performance characteristic.

Three Common Optimisation Scenarios are:

- Nominal-the-best: When a specified value is most desired (neither a small value nor larger value is desirable)

$$S / N = 10 \log_{10} \frac{\mu^2}{\sigma^2}$$

- Larger-the-better:

$$S / N = -10 \log_{10} \frac{\sum u^2}{n}$$

- Smaller-the-better:

$$S / N = -10 \log_{10} \frac{\sum \mu^2}{n}$$

μ is the signal mean and n is the number of trials.

Therefore, the optimal level of the process parameters is the level with the highest S/N ratio. Furthermore, a statistical analysis of variance (ANOVA) is performed to see which process parameters are statistically significant. With the S/N and ANOVA analyses, the optimal

combination of the process parameters can be predicted. Finally, a confirmation experiment is conducted to verify the optimal process parameters obtained from the parameter design.

4. EXPERIMENTATION

The experimental setup involves a vertical milling machine with dynamometer to measure the cutting forces (Fig 4.1). A spur gear of 32 number of teeth is cut using this machine. The gear blank used is mild steel and the tool used is high speed steel milling cutter. The machine has a speed ranging from 100 to 1500 rpm with a spindle power of 3 HP. The material composition of the MS Blank piece used is given in table 4.1 Individual gear tooth profiles, each with different combination of cutting parameters, that is, speed -feed -depth of cut; are cut using the milling machine. During milling the cutting forces are noted down from the dynamometer. After each of the individual experiment the surface finish of the work is measured using a surface finish tester.

After completing the experiments Minitab Software is used to apply the signal-to-noise ratio and ANOVA graphs are plotted. From the peak points obtained from the graphs the optimum combination of parameters can be deduced. After obtaining the optimum combination, a conformation experiment has to be conducted to verify the result.

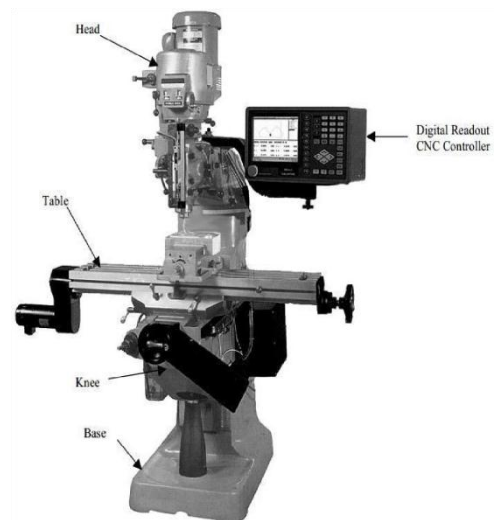

Fig 4.1 Vertical Milling machine

4.1. Steps involved in Taguchi optimization:

The use of Taguchi's parameter design involves the following steps:

- Identify the main function and its side effects.
- Identify the noise factors, testing condition and quality characteristics.
- Identify the objective function to be optimized.

- d) Identify the control factors and their levels.
- e) Select a suitable Orthogonal Array and construct the Matrix
- f) Conduct the Matrix experiment.
- g) Examine the data; predict the optimum control factor levels and its performance.
- h) Conduct the verification experiment.

Objective Function: Smaller-the-Better

- S/N Ratio for this function:

$$S/N = -10 \log_{10} \frac{\sum_{n=1}^i \mu^2}{n}$$

where, n= Sample Size, and μ = signal mean

4.5. Control factors and levels:

TABLE 4.5.1 Control Factors and levels

FACTORS	LEVELS		
	1	2	3
Cutting speed(v, rpm)	300	500	700
Depth of cut(t, mm)	0.75	1	1.25
Feed rate(f, mm/min)	20	40	60

4.2. Main functions and side effects:

Main function: Spur gear milling operation on a vertical milling machine.

Side Effects: Variation in surface finish and variation in cutting force.

Before proceeding on to further steps, it is necessary to list down all the factors that are going to affect or influence the facing process and from those factors one has to identify the control and noise factors (table 4.2.1).

TABLE 4.2.1 Control factors and noise factors

Control factors	Noise Factors
Cutting speed	Vibration
Depth of cut	Raw material variation
Feed rate	Machine Condition
Coolant	Temperature

After listing the control and the noise factors, decisions on the factors that significantly affect the performance will have to be ascertained and only those factors must be taken in to consideration in constructing the matrix for experimentation.

4.3. Quality characteristics and testing conditions:

- a) Quality Characteristic: Surface finish
- b) Work piece material: Mild Steel
- c) Cutting tool: High Speed milling tool
- d) Operating Machine: Vertical milling machine
- e) Testing Equipment: Dynamometer, surface finish tester

4.4. Objective function:

Objective function helps to determine the optimal combination of factors. The objective function taken is given below. Any of the three objective functions can be chosen. We have chosen smaller-the-better.

The factors and their levels were decided for conducting the experiment, based on a discussion that was held with group members and also considering the guide. The factors and their levels are shown in table 4.5.1.

4.6. Selection of Orthogonal array:

To select an appropriate orthogonal array for conducting the experiments, the degrees of freedom are to be computed.

The same is given below:

Degrees of Freedom: 1 for Mean Value, and 6= (2x3), two each for the remaining factors.

Total Degrees of Freedom: 8

The most suitable orthogonal array for experimentation is L9 array. Therefore, a total nine experiments are to be carried out.

TABLE 4.6.1 Orthogonal array chart for L9

Experiment No.	Control Factors		
	1	2	3
1	1	1	1
2	1	2	2
3	1	3	3
4	2	1	3
5	2	2	1
6	2	3	2

7	3	1	2
8	3	2	3
9	3	3	1

TABLE 4.7.2.1 Orthogonal chart with combinations

Exp. No.	Speed (rpm)	Depth of cut (mm)	Feed (mm/min)
1	300	0.75	20
2	300	1	40
3	300	1.25	60
4	500	0.75	20
5	500	1	40
6	500	1.25	60
7	700	0.75	20
8	700	1	40
9	700	1.25	60

4.7. Matrix experiment:

4.7.1. Setup:

1. Siemens CNC Milling (rpm - 60 to 6000)
2. Kistler Dynamometer
3. Mitutoyo SJ-210 surface roughness tester
4. Workpiece – Mild steel gear blank 64mm dia.
5. Tool – High speed milling cutter

4.7.2. Procedure:

1. The mild steel work piece is placed and fixed on CNC milling machine equipped with dynamometer setup.
2. Required CNC program is fed on the control panel.
3. The tool is fixed and centred on the machine.
4. Finally, the machine is turned on and a trial run is conducted.
5. The first run of the tool is done with the first combination provided by the orthogonal array. (table 4.7.2.1).
6. The corresponding data of cutting forces obtained are recorded.
7. The procedure is repeated for all the 9 combinations.
8. Similarly, the cutting forces recorded by the dynamometer is taken.
9. After the completion of recording the cutting force the cut work piece is removed from its holder and delivered for inspecting the surface roughness.
10. The roughness tester’s testing head is placed on the cut surface and the tester is switched on. After a time of 30 seconds the value of surface roughness was displayed and it is recorded of each combination of machined surface.
11. The obtained results are tabulated and resultant cutting force is also found out.

4.7.3. Results:

TABLE 4.7.3.1 Experimental results

Exp No.	Fx (force in x direction, N)	Fy (force in y direction, N)	Fz (force in z direction, N)	Fr (Resultant force, N)	Ra (Surface roughness, μm)
1	51.42	11.9	18.84	61.532	2.441
2	76.22	16.56	24.11	81.639	3.030
3	109.5	23.5	22.74	114.279	4.942
4	37.84	16.33	28.76	50.256	2.878
5	78.28	21.13	24.64	84.740	3.114
6	49.59	23.12	23.04	59.407	2.350
7	64.7	23.73	26.4	73.798	3.386
8	40.59	25.48	31.89	57.565	2.234
9	76.98	33.49	44.49	95.007	3.073

5. RESULTS AND ANALYSIS

5.1. Analysis of S/N ratio:

In the Taguchi method, the term ‘signal’ represents the desirable value (mean) for the output characteristic and the term ‘noise’ represents the undesirable value(S.D.) for the output characteristic. Therefore, the S/N ratio is the ratio of the mean to the S.D. Taguchi uses the S/N ratio to measure the quality characteristic deviating from the desired value. As mentioned earlier, there are three categories of quality characteristics, i.e. the-lower-the-better, the higher the-better, and the-nominal-the-better. The-lower-the-better quality characteristics for surface roughness should be taken for obtaining optimal cutting performance. Regardless of the lower- the-better or

higher- the-better quality characteristic, the greater S/N ratio corresponds to the smaller variance of the output characteristic around the desired value.

1. The MINITAB software is used for this process.
2. The Taguchi method function is selected and the L9 orthogonal array is selected.
3. The corresponding values of the combinations are entered to the array.
4. Now the Taguchi analysis function is selected and the S/N ratio smaller the better is selected and the graph is plotted. (Fig 5.1.1 and 5.1.2)

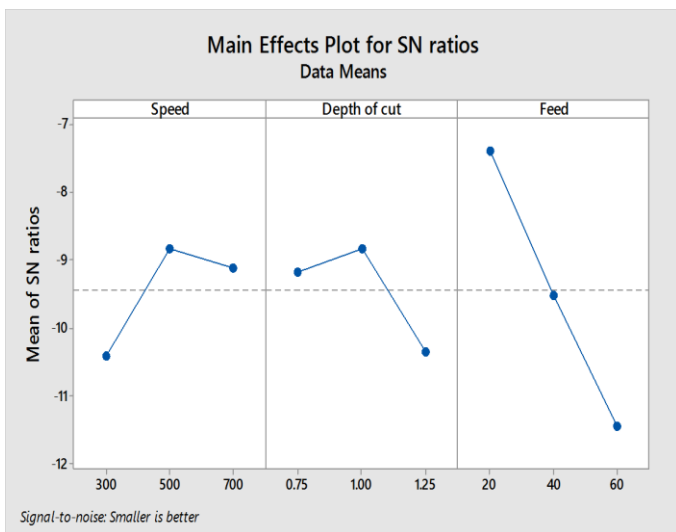

Fig 5.1.1 S/N plot for Surface roughness

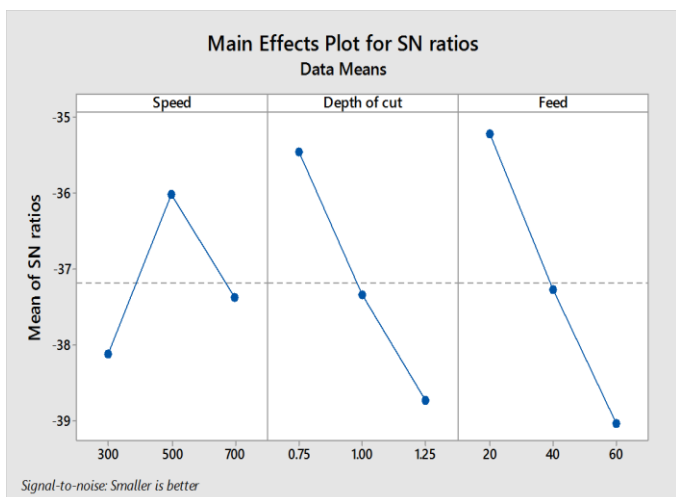

Fig 5.1.2 S/N plot for Cutting force

5. The peak points obtained in this graphs are taken as the optimal combination.
6. Thus we obtain two feasible combinations:

TABLE 5.1.1 Feasible combinations

Speed (rpm)	Depth of Cut (mm)	Feed (mm/min)
500	1	20
500	0.75	20

7. To estimate and predict the resultant cutting forces and surface roughness obtained in these combinations Regression forecasting method is used and ANOVA is conducted to understand the contribution of each factors to the result.

5.2. Regression equations:

The obtained values are both feasible to be selected as permissible combination but with the help of the regression equations we can predict the outcomes of these result. By comparing these outcomes, we can effectively choose the best combination.

1. The regression function in the MINITAB is selected.
 2. The parameters and response variables are entered.
 3. The resulted equations are provided based on calculating all the combinations.
- Predicted values at **(500, 0.75, 20)**

$$Ra = 1.187 - 0.001433 \text{ Speed} + 1.107 \text{ Depth of cut} + 0.03681 \text{ Feed} = 2.037\mu\text{m}.$$

$$Fr = 1.5 - 0.0259 \text{ Speed} + 55.4 \text{ Depth of cut} + 0.786 \text{ Feed} = 45.82\text{N}.$$

- Predicted values at **(500, 1, 20)**

$$Ra = 1.187 - 0.001433 \text{ Speed} + 1.107 \text{ Depth of cut} + 0.03681 \text{ Feed} = 2.314\mu\text{m}.$$

$$Fr = 1.5 - 0.0259 \text{ Speed} + 55.4 \text{ Depth of cut} + 0.786 \text{ Feed} = 59.67\text{N}.$$

5.3. ANOVA:

The purpose of the analysis of variance (ANOVA) is to investigate which design parameters significantly affect the quality characteristic. This is to accomplished by separating the total variability of the S/N ratios, which is measured by the sum of the squared deviations from the total mean S/N ratio, into contributions by each of the design parameters and the error. First, the total sum of squared deviations (SS) from the total mean S/N ratio can be calculated as:

$$SS = \sum_{i=1}^n (n_i - n_m)^2$$

where n is the number of experiments in the orthogonal array and n_i is the mean S/N ratio for the i th experiment.

The total sum of squared deviations SS is decomposed into two sources: the sum of squared deviations SS due to each design parameter and the sum of squared error. The percentage contribution by each of the design parameters in the total sum of squared deviations is a ratio of the sum of squared deviations due to each design parameter to the total sum of squared deviations SS.

Statistically, there is a tool called an F test named after Fisher to see which design parameters have a significant effect on the quality characteristic. In performing the F test, the mean of squared deviations due to each design parameter needs to be calculated. The mean of squared deviations is equal to the sum of squared deviations divided by the number of degrees of freedom associated with the design parameter. Then, the F value for each design parameter is simply the ratio of the mean of squared deviations SS to the mean of squared error. Usually, when $F > 4$, it means that the change of the design parameter has a significant effect on the quality characteristic.

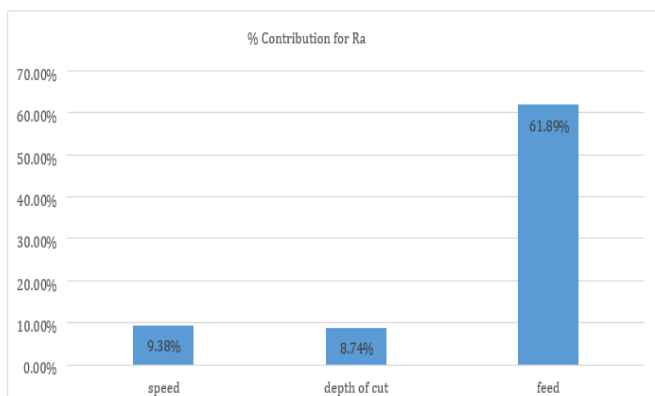

Fig 5.3.1 Percentage contribution for surface roughness

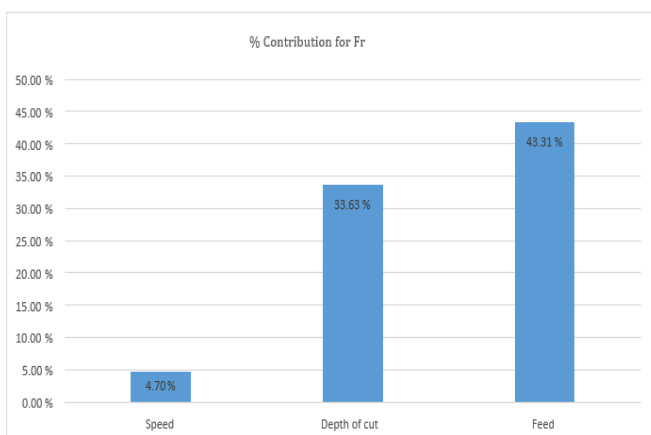

Fig 5.3.2 Percentage contribution for cutting forces

TABLE 5.3.1 ANOVA for Surface roughness

Source	SS	Contribution	F value
Speed	0.4931	9.38%	2.35
Depth of cut	0.4593	8.74%	2.19
Feed	3.2516	61.89%	15.49

TABLE 5.3.2 ANOVA for Cutting forces

Source	SS	Contribution	F value
Speed	161	4.70%	1.28
Depth of cut	1151	33.63%	9.16
Feed	1482.5	43.31%	11.79

The F test values obtained in both ANOVA process are carefully analyzed. For the surface roughness (TABLE 5.3.1) we can see that the f values go beyond 4 i.e 15.49 for feed, thereby contributing the most (Fig 5.3.1). For the cutting forces (TABLE 5.3.2) we can see that the f values go beyond 4 i.e 9.16 and 11.79 for depth of cut and feed respectively (Fig 5.3.2). The contribution of speed is low since the work piece is fairly a brittle material i.e cast iron. The percentage contribution of these responses are plotted in a contribution chart for easy reference.

6. CONCLUSION

The Taguchi method provides a systematic and efficient methodology for the design optimization of the cutting parameters with far less effect than would be required for most optimization techniques. It has been shown that cutting forces and surface roughness can be reduced significantly for milling operations.

- From the S/N plots and ANOVA we can decide that the optimum combination for milling is 500 rpm, 0.75 mm, 20 mm/min.
- It is found that Feed rate has a major role in deciding the value of Ra and Feed rate and depth of cut plays the major share in deciding the value of Cutting force.
- The value of surface roughness needed for standard milling is from 75µin to 125µin. The predicted result for this combination is 2.03µm ie approximately equal to 79.921µin. The minimum cutting force obtained is 45.82N.

From this study, the optimum combination of cutting parameters for minimum surface roughness and minimum cutting forces is determined.

7. ACKNOWLEDGEMENT

We wish to express our deep sense of gratitude to our beloved Chairman Sri. K.G Madhu and all trust members of Ammini College of Engineering for providing all the necessary facilities to carry out the project work. We express our sincere thanks to our Principal Dr. Shashi Dharan for his support. We express our gratitude to Mr. Pradeesh A.R, Head of the Department, of mechanical engineering for his encouragement and timely advice that made us to carry out the project work successfully. We would like to express our sincere appreciation to our project guide Mr. Sudeesh S, Assistant professor, Department of Mechanical Engineering for the support and guidance he has extended to us in the completion of our project work. We extend our sincere thanks to the faculty and staff members for their valuable suggestions and help throughout our project work. Besides these we like to express our sincere thanks to our friends and family for their help and support towards the successful completion of the project work.

8. REFERENCES

- [1] Journal of Materials Processing Technology 141 (2003) 51-59. S. Shaji, V. Radhakrishnan. Analysis of process parameters in surface grinding with graphite as lubricant based on the Taguchi method.
- [2] Journal of Materials Processing Technology 145 (2004) 84-92 J.A Ghani, I.A Choudhury, H.H Hassan. Application of Taguchi method in the optimisation of end milling parameters.
- [3] Materials and Design 28 (2007) 1379-1385. M. Nalbant, H. Gokkaya, G.Sur, Application of Taguchi method in the optimisation of cutting parameters for surface roughness in turning.
- [4] International Journal of Advanced Trends in Computer Science and Engineering, Vol.2, No.6: 129-135 (2013) Special Issue of ICETEM 2013. Pratyusha J, Ashok Humar U. Optimization of process parameters for milling using Taguchi methods.30 November 2013.
- [5] International Refereed Journal of Engineering and Science (IRJES). Srinivas Athreya, Dr. Y. D Venkatesh. Application of Taguchi method for optimisation of process parameters in improving the surface roughness of lathe operation.3 November 2012.
- [6] International Journal of Engineering Research & Technology (IJERT) ISSN: 22780181. M. Aravind, Dr. S Periyasammy. Optimisation of Surface Grinding process parameters by Taguchi method and response Surface methodology.5 May 2014.
- [7] Journal of Industrial Technology 2001; 17 (2 A):1-8. Yang JL, Chen JC. A systematic approach for identifying optimum surface roughness performance in end-milling operations.
- [8] Journal of Materials Processing Technology 1998; 84:122-9. Yang H, Tarng YS. Design optimization of cutting parameters for turning operations based on the Taguchi method.
- [9] Journal of Materials Processing Technology 2002; 127:1-7. Lin TR. Experimental design and performance analysis of TiN coated carbide tool in face milling stainless steel.
- [10] Journal of Materials Processing Technology 1999; 95:90-6. Nian CY, Yang WH, Tarng YS. Optimization of turning operations with multiple performance characteristics.

BIOGRAPHY



Graduated in Mechanical Engineering from NSS College of Engineering in 2003 and M.Tech in Production and Industrial Engineering from MACE, Kothamangalam in 2009.