

Exploitation of Vehicle by GSM and GPS using Fingerprint Authentication

Kavyashree B R¹, Dr. Chandrappa D N²

¹ Mtech, Digital Communication and Networking, SJBIT, Bangalore, India

² Professor of the Department, ECE, SJBIT, Bangalore, India

Abstract - Current day's a vehicle larcenies are expanding quickly. As of late vehicle public system is getting huge renown on account regarding an increasing number by hijacked vehicles. Vehicle larceny is occurring on stopping and sometime driving in unsecured localities. With a particular ultimate objective to overcome this issue, Vehicle through Fingerprint authentication employing GSM and GPS is accomplished. The exploration of this work explores whereby to secure a decisive intention of a vehicle from this sort of compelling and affords greater safekeeping toward vehicles. Also, this task is performed as minimal effort vehicle larceny control plot utilizing a microcontroller along with the use of GPS also GSM innovation. The exploitation of GSM with GPS developments enables the method to track the issue that gives the most up-to-date data about on-going treks.

Key Words: Fingerprint, GMS, GPS, Vehicle larceny, SMS.

1. INTRODUCTION

A Vehicle Positioning Technique includes the setting up of an automated scheme against a vehicle or vehicle convoy which facilitates the proprietor or individual to track the location of vehicles and process the information data provided. Present Vehicle Positioning Technique (VPT) is equipment that used to allocate location of vehicles provides various techniques like module of GSM as well as GPS along with other radio systems navigation functioning through satellites from end to end ground based stations [1]. GSM with GPS based Vehicle tracking along with location method affords nominal mapping of real time based vehicle location tracking. The technique employs position of geographical areas also the data of time through a Global Positioning Satellites [2].

After evolving the fingerprint developed through National Crime Records Bureau of a ministry and home affairs [3] initiated an investigation with records of crime in India. Advanced innovative equipment as well as the different status of State Fingerprint Bureau was analyzed. M.S.A. Megat, Ali M.F. Saaid besides Kamaludin M.A [4], is using GPS vehicle location with system global of mobile device to conclude the system accuracy which shows the error of magnitude in which the conventional received data reclined through this methodology. The K. Tejasri also D. Narendar Singh, [5]. Is an overview of ARM 9 with a real time identity theft using vehicle including control system. A Sharmila Chidaravalli, Andrews Samraj, Manjunath T.K likewise N.Maheswari [6] depict locking & unlocking from Theft

Vehicles Utilizing CAN. Mudit Singhal, as well as Sudeep Singh [7], ensured similar works. Paul Benjamin Fleischer, Robert Adjetey Sowah, Atso Yao Nelson, also Appah Bremang [8] provides a ready structure for announcing operational theft also unintentional events. Pati.N [9] states with a postulation of video surveillance with tracking of moving civilian vehicles.

In this analogy, a technique has been advanced based on ARM7 microcontroller that comprises GSM SIM 800L module by Fingerprint R305 sensor. The research also introduces a Fingerprint security system for a vehicle also fingerprint confirmation of the proprietor of a vehicle remains used to safeguard against the vehicle larceny. The Fingerprint identification relegates to the automated procedure of identifying or confirming the personality through individual assembled on the analogy of the dual fingerprints process. Before initiating the vehicle a driver gets to register using the fingerprint scan so that only authorized personnel will start a vehicle. In this instance, when location area of vehicle gets changed short of particular verification of fingerprint, then the method will be considered as anomalous condition. At that point, an SMS through a mobile will be sent to a proprietor of a vehicle through a URL by means of 'GOOGLE MAP' [10] existent with facilities of a present area of a vehicle. SMS with an updated area's co-ordinate location will be later guided to a proprietor through each intervening time of 5 seconds awaiting liability of accurate check fingerprint verification.

2. PROPOSED METHODOLOGY

A Fingerprint Sensor R305 [11] is additionally utilized for a fingerprint check. There are numerous unique finger impression sensor innovations i.e. optical capacitive, RF, ultrasonic, piezoelectric, piezo-resistive, MEMS. Optical sensor innovation has been utilized in this methodology. Scanned finger picture is carefully handled then put away in memory as a format. A Fingerprint impression occupied through individual by driver of vehicle via system device is analyzed at beginning of a process. Fingerprint verification is completed by utilization in contrast of selected scanned picture image that is designed for examination with the confirmation of a Fingerprint.

Then the co-ordination based connection includes an edge of the location co-ordinates along with a latitude also longitude provides a particular co-ordination, the last co-ordinate is prominent as it is proficient what's more, exact. With

unknown individual over a control of vehicle without verified Fingerprint an instantaneous SMS will be sent to the proprietor. At that point a GPS allocates a signal through the satellite while locating the co-ordination of vehicle. Then while sending an SMS to a registered individual of vehicle. A Vehicle larceny of fingerprint mechanisms consists of two modes. To initiate the vehicle consistent systematic flow chart with an entire process illustrated in Figure 1.

- [1] First, authorized person will be authenticated and hence registered proprietor using fingerprint scan can start the vehicle and the vehicle will be in ON condition.
- [2] In the Second mode, an unauthorized person attempts to start the vehicle, at this point an immediate message will be assigned to the registered proprietor along with the location co-ordinates of longitude also latitude direction will be known through Google map and hence vehicle will be in OFF condition.

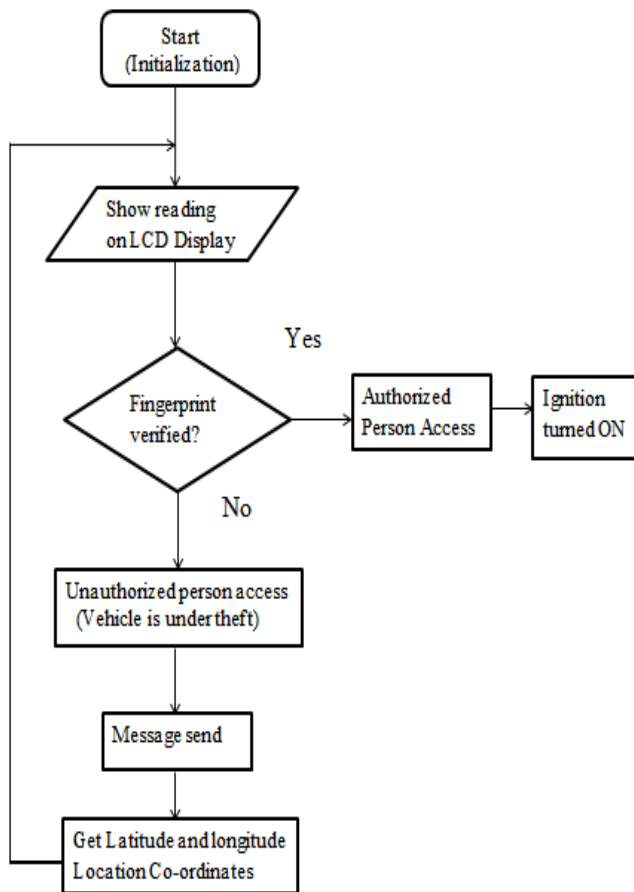

Figure 1: Flowchart of vehicle larceny fingerprint check

Vehicle proprietor will get an allocation anytime through SMS directed by vehicle. The vehicle initiated by a switch, when switch is initiated by authorized individual vehicle starts moving. When an unauthorized individual Starts vehicle it doesn't move, a proprietor will get an immediate SMS. Furthermore a vehicle larceny in addition with analysis of GSM connectivity is done.

After initialization of vehicle a receiver of GPS, get its co-ordinate's by latitude also longitude along with time in addition to several information data. The data of this information will be updating for each second. Then after vehicle starting, an individual gets initial co-ordinate place beginning of receiver GPS alongside those correct locality track taking place through Google map. Subsequent informed co-ordinates are verified by a distance through an updated exact co-ordinate within a distance of few meters.

3. SYSTEM DESIGN

The system development of this expansion of research, an ARM 7 microcontroller performance is implemented also interfaced through several hardware peripherals. The microcontroller ARM 7 is implemented toward GPS receiver then modem of GSM. The modem GSM is employed for allocating the position from a specific vehicle of one isolated area. SIM800L [13] is applied in this analysis. Both the GPS is including GSM Modules involved in addition added to one device. Fingerprint Sensor R305 [12] is functioned as fingerprint module device directly interfaced with TX also RX Port through LPC2148.

Figure. 2 illuminate a proposed system methodology with positioning of vehicle with Fingerprint authentication. Both GSM in addition to GPS procedures have a distinct antenna. The GSM along with GPS as well as a Fingerprint R305 sensor device are then connected through the LPC2148.

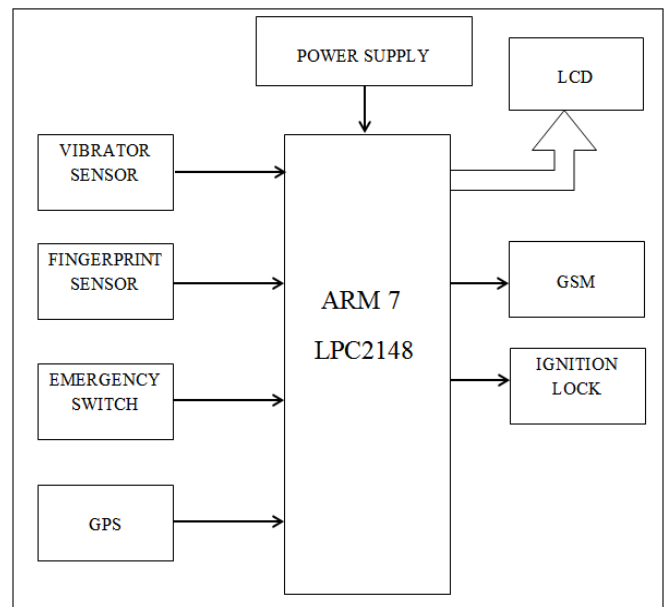

Figure 2: Proposed System Methodology

The appropriate LCD is displayed by programming with an LCD interface outline. The cord RS232 link is carried out through communication of serial port. The primary part of this system is LPC 2148 microcontroller. It is in charge of all checking besides creating the sources of information data product individually. The Keil 4 version software through an Embedded C is programmed using flash magic burner which

is interfaced by ARM 7 LPC2148 at baud rate of 9600 with an oscillator frequency of 12 MHz with the COM Port PC 14 interfacing through UART 0 Port.

4. SCHEMATIC DIAGRAM

In a vehicle positioning technique is installed which includes ARM 7, SIM800L [12] besides Fingerprint Sensor RC305 [11]. SIM800L then Fingerprint sensor device R305 are connected to an ARM 7 via COM port of serial transmission. Figure 3 demonstrates a Schematic diagram with vehicle positioning technique. Several parts by positioning of vehicle are designated below with respect to the schematic diagram shown in Figure 3.

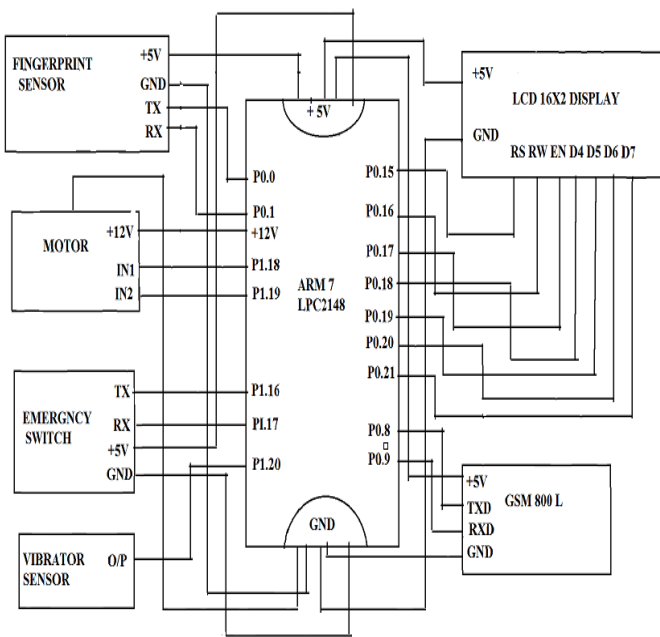

Figure 3: Schematic Diagram

4.1 ARM 7 LPC 2148 Microcontroller

ARM 7 LPC2148 [14] is effective microcontroller BRAIN of method based on 16-bit/32-bit a tiny LQFP64 package with the microcontroller of ARM 7 TDMI-S. A LPC2148 have 512 KB memory of flash. SRAM by 40 KB in addition to I2C EEPROM by 4KB.

With a 64 input/output digital pins along with 14 analogue inputs also 2 UARTs (serial hardware ports). A bit operated through a 128 wide interface a stimulating operator empowers speedy 60 MHz activity. LPC2148 interfaced through a UART 0 Port.

4.2 GPS/GPRS/GSM SIM800L

The GSM SIM800L[12] is quad-band GSM or GPRS Module operates at frequencies GSM850 MHz, DCS1800MHz, EGSM900MHz and PCS1900MHz. The GPRS with multi-opening class 12 or else class 10 then backings the GPRS

coding plans through CS 4, CS 3, CS 2, as well as finally with the CS 1.

A technology by GPS with a navigation of satellite position as well GSM is implied in this method. With both technology of GPS along with GSM will be maintained by a system, several proceeding determination of tracing position are feasible through anyplace moreover at any time through coverage by signal locality.

4.3 Fingerprint Sensor R305

Sensor R305 Fingerprint [11] module is interfaced with TTL UART via a LPC2148. A fingerprint data that can be stored by user with configuration with a 1:1 otherwise 1: N mode by identifying the individual. A MAX232 is interfacing with PC, directly interfaces with 5V microcontroller. A R305 Sensor has capacity of storage around 256 several fingerprints also it has merely capable of fingerprint identification by 40° with 500 dpi of resolution. The R305 operated at 9600 bps baud rate. A dc driver motor is connected through to the TX along with a RX port of LPC2148.

5. SYSTEM IMPLEMENTATION & RESULT

The methodology by the development of this research, an LPC2148 ARM 7 microcontroller enactment is interfaced through several hardware peripherals with this system design is applied. The ARM7 LPC2148 microcontroller is implemented toward GPS receiver and modem of GSM. The modem GSM is employed for allocating the position from a specific vehicle of one isolated area. SIM800L [12] is applied in this analysis. Both the GPS is including GSM Modules involved and added to one device. Fingerprint Sensor R305 [11] is operated as Fingerprint device interfacing through LPC2148 along with dc motor including Emergency Switch.

After implementation of hardware along with software related works, a complete system will be verified by a vehicle to safeguard system by vehicle positioning which will be well functioned then meets the required condition.

At a time vehicle is moved out with an imaginary geo-fence without an appropriate authentication of fingerprint, at that time a SMS will be directed to the proprietor's mobile phone through a URL link with coordination of a vehicle. Next process is to send SMS spontaneously through each 5 seconds interval while together with updated locations of a co-ordinates. Until accessed by an appropriate fingerprint then by directing through a SMS will be halted.

The three foremost important aspects of this method are as follows.

1. First the device will be detected which will send SMS as well as the User should register to access the vehicle

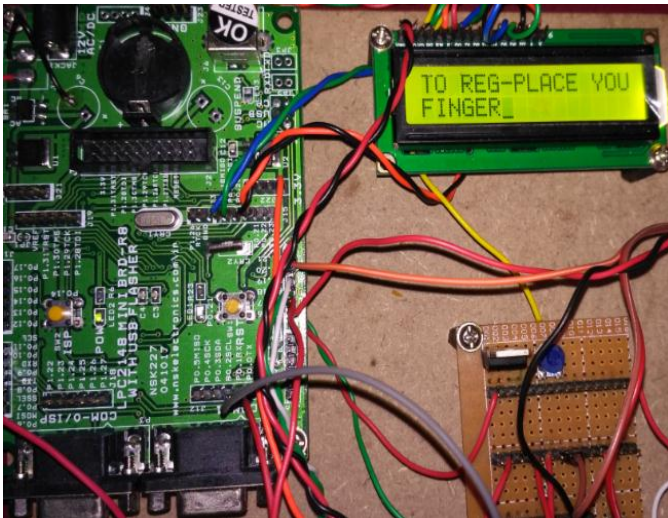

Figure 4: User Register the Fingerprint

2. Authenticated by an authorized person the Vehicle Starts moving.

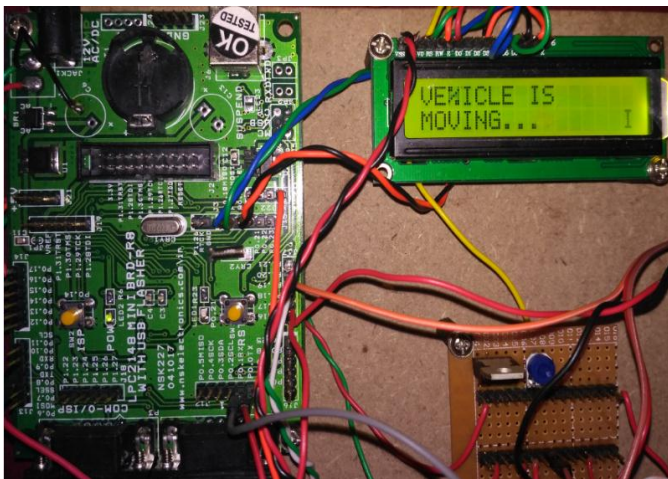

Figure 5: Vehicle Start Moving

3. An unauthorized person initiate the vehicle doesn't start and then the vehicle is under theft.

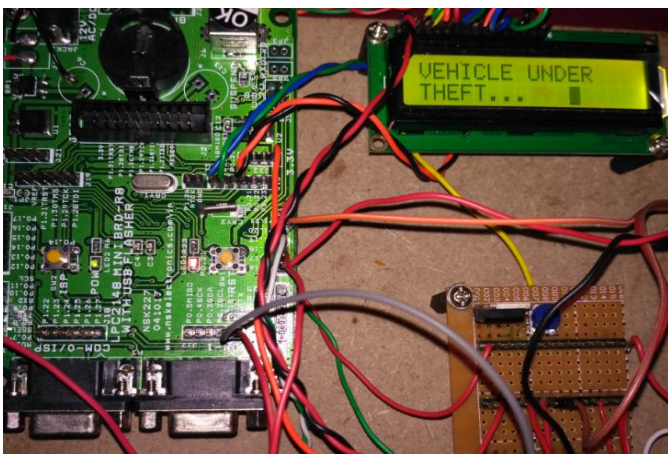

Figure 6: Unauthorized person access (Vehicle under theft)

The immediate SMS will be sent if an unauthorized person accesses a vehicle, by locating co-ordinates of longitude as well as latitude through a SMS and then by clicking the URL the location will be associated through Google map.

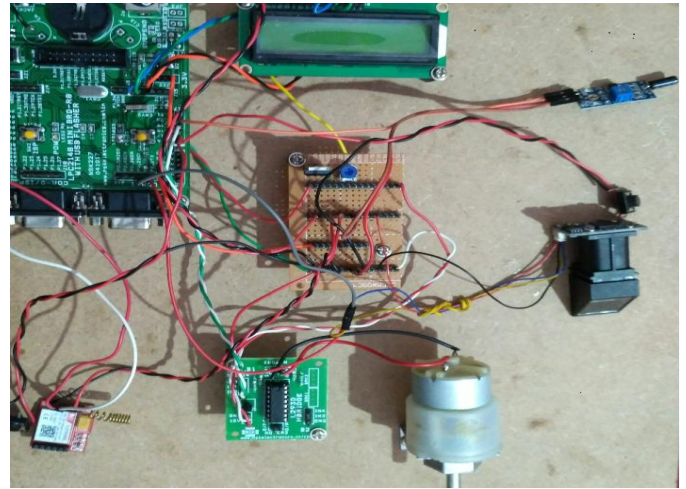

Figure 7: Overview of System Implementation

Final analysis of this method that tracks the vehicle, when authorized individual access with verified fingerprint the vehicle starts moving that is ignition of vehicle will be turned ON. If an unauthorized individual access vehicle, ignition of vehicle will be turned OFF, thereby an instant SMS along with location will be directed through a registered mobile proprietor.

After clicking on the URL link data provided SMS, a location through the Google map is showed along with co-ordination of latitude also longitude. Figure 8 a. illustrates a vehicle position on the map. In Figure. 8 b, initial location screenshot of a vehicle pointed by the same place beyond the distance of few meters. Resulting screenshots are position of vehicle moving at altered location after each 5 seconds interval of starting SMS. A various co-ordinates of vehicle position can be allocated in a distance of few meters.

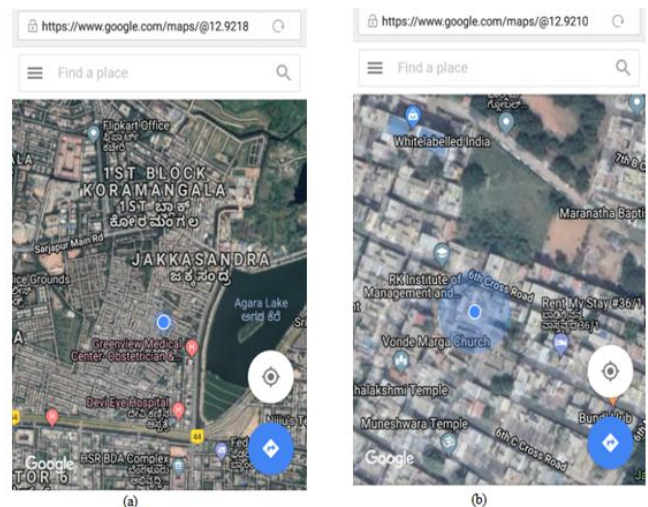

Figure 8: Different Location co-ordinates positioned by Google map

6. CONCLUSIONS AND FUTURE SCOPE

The implementation of this project is based on the vehicle positioning system through a Fingerprint authentication which provides contradiction of vehicle larceny. In this paper, vehicle position can be allocated through GSM of vehicle also deterrence from burglary can be completed using lowest cost in real-time mode in addition with vehicle navigation. GSM along with GPS technology present an effective vehicle larceny technology with optimal cost of vehicles. The entire analogy of this project dispute through the design and an implementation of a larceny control system of a vehicle using fingerprint authentication.

In future, face recognition with authentication of vehicle can be implemented to provide more security. A module of GSM or GPS with microphone could be interfaced so that during burglary action, a call can be made via voice.

REFERENCES

- [1] Mohammad A. Al-Khedher, "Hybrid GPS-GSM Localization Automobile Tracking System, "International Journal of Computer Science & Information Technology (IJCSIT)", Vol. 3, No 6, pp. 75-85, Dec. 2011.
- [2] Committee on the Future of the Global Positioning System; National Academy of Public Administration (1995). The global positioning system: a shared national asset: recommendations for technical improvements and enhancements. National Academies, National Research Council, U.S.A., 2013.
- [3] (2018) Official Indian Government website about the crime records of vehicle and related topics. Available [Online]: <http://ncrb.gov.in/>
- [4] M.F. Saaid, M.A. Kamaludin, M.S.A. Megat Ali, "Vehicle Location Finder Using Global Position System and Global System for Mobile", in ICSGRC'14, 2014, p.279-284.
- [5] D. Narendar Singh, K. Tejasri, "Real Time Vehicle Theft Identity and Control System based on ARM 9", International Journal of Latest Trends in Engineering and Technology(IJLTET), Volume 2, Issue 1, January 2013.
- [6] Manjunath TK, N.Maheswari, Andrews Samraj, Sharmila Chidaravalli, "Locking and Unlocking of Theft Vehicles Using CAN", Proceedings of 2013 International conference on Green high performance computing, IEEE, March 2013.
- [7] Mudit Singhal and Sudeep Singh, "An Embedded Interface for GSM Based Car Security System", Int. Conference on Computational Intelligence, Communication Systems and Networks, IEEE Computer society, 2012.
- [8] Paul Benjamin Fleischer, Atso Yao Nelson, Robert Adjetey Sowah, Appah Bremang "Design and development of GPS /GSM based vehicle tracking and alert system for commercial inter-city buses", IEEE, 2012, 4th international Conference on Adaptive Science & Technology(ICAST).
- [9] Tracking of Moving Civilian Vehicles", M. Eng. Thesis, University of North Texas, Denton, USA Pati.N, "Occlusion Tolerant Object Recognition Methods for Video Surveillance and, Dec. 2007.
- [10] The GOOGLE MAP website. [Online]. Available: <http://maps.google.com>.
- [11] Fingerprint Sensor R305 Module Datasheet <http://www.rhydolabz.com/documents/fingerprintmodule.pdf>
- [12] The SIM COM website. [Online]. Available: <http://www.Simcom.ee/>
- [13] The User Manual of ARM7 <https://www.nxp.com/docs/en/user-guide/UM10139.pdf>