

# Simulation of MPPT based Controlling Mechanism for improving the efficiency of Solar Photovoltaic based operated system.

Ayushi Wasnik<sup>1</sup>, Radharaman Shaha<sup>2</sup>

<sup>1</sup>M.Tech Student, AGPCE, Nagpur, Maharashtra, India

<sup>2</sup>HOD, Electrical Engineering Department, AGPCE, Nagpur, Maharashtra, India

\*\*\*

**ABSTRACT**— In recent years the attention towards utilization of renewable sources of energy has been increased drastically. Solar energy is one of the important renewable sources of energy since it is clean, pollution free and inexhaustible. The output Power of Photovoltaic array always changes with weather conditions i.e., solar irradiation and atmospheric temperature. The energy that is being absorbed by photovoltaic cells is not being completely utilized because of irradiance effects. Hence Maximum power point tracking techniques (MPPT) are employed in photovoltaic systems to utilize the energy that is absorbed. These techniques vary in many aspects as range of effectiveness, hardware, sensor required, and cost. This project presents a comparison analysis of existing MPPT techniques and then an optimal controller is designed and implemented which has a better performance in achieving high efficiency. The model includes accepting the input from the available source by considering a step variation in the input conditions, a physical to simulink converter circuit, a DC-DC converter circuit with designed parameters according to the load considered and a controller circuit.

**Key Words** — Photovoltaic array, Maximum power point tracking, Simulink, DC-DC converter.

## 1. INTRODUCTION

The increase in the demand for electricity is emerging towards harnessing of solar energy using photovoltaic systems. The tremendous change in the living environment due to increase in pollution and global warming effect are driving towards increase in the utilization of renewable energy resources that are cheaper carbon emissions. To overcome the problems it is necessary to optimize the design of Photovoltaic system components. Maximum power point tracking (MPPT) is used in photovoltaic systems to maximize the photovoltaic array output power, irrespective of the temperature and radiation conditions. The role of MPPT controller is to track new modified maximum power point in its corresponding nonlinear curve whenever a variation in temperature and/or irradiance occurs. The output tracked from the PV system does not maintain constant hence to charge the battery that requires a constant current we need a converter circuit which operates the charging by switching of PWM (Pulse width modulated) signal. The Photovoltaic array operating schemes consist of mainly a maximum power point tracking controller, a charge

controller for battery backup and load voltage controller. This arrangement must be considered as a whole unit since all these parts are tied up together and need to be controlled together. The MPP tracking under conditions of changing irradiance. To test the MPPT algorithms according to the irradiation profiles proposed in the standard, a simplified model was developed, because the simulation time required in some of the cases cannot be reached with the detailed switching model of a power converter in a normal desktop computer. The reason for that is that the computer runs out of memory after simulating only a few seconds with the complete model. Finally, the simplified model is verified by comparing its results with those obtained from a model containing a detailed model. The design of the simulation model of the proposed system is carried in simulink environment and it requires a physical to real time interface circuit for connecting the panel output as the input to controller circuit. The Pulse width modulation technique is employed in the controller design to achieve the output at highly varying switching speeds. The solar chargers use technology similar to other high quality battery chargers. When a battery reaches the regulation set point the PWM algorithm slowly reduces the charging current to return maximum amount of energy to the battery in the shortest time.

## 2. LITERATURE SURVEY

As mentioned, solar power is considered as a very viable potential renewable energy source because the largest energy source available is the sun, which supplies practically limitless energy. The energy available from the sun far exceeds any foreseeable future demand. In this advancing era of technology we are more concerned about the advancements made in technology rather than thinking upon the alternative sources of energy. Energy costs and decreasing supplies of fossil fuels, emphasis on protecting the environment and creating sustainable forms of power have become vital, high priority projects for modern society. Since, as solar energy which is also considered a renewable form of energy can be used to offset some of the power coming from the main grid that is generated by let us say nonrenewable sources of energy. And creating these renewable sources in such a way that these provide us with the maximum efficiency is our main goal. This paper proposes a solar tracking system designed with microcontroller and LDR's that will actively track the

sun and change its position accordingly to maximize the energy output. The LDR's incorporated on solar panel helps to detect sunlight which in turn moves the panel accordingly.

The simulation work presented in this paper was carried out on microcontroller based Automated Solar Battery Charge Controller (ASBCC) for controlling the overcharging and deep discharging of a battery. The purpose of ASBCC is switching with help of programmed controller. Battery Charge Circuit (BCC) regulates the solar power to charge the battery to maximum specific level. Equipment's monitoring has always been essential. Software based Graphical User Interface (GUI) shows the digital values of output voltage, current, temperature and power of solar panel and battery charged status. These data is stored into the computer data base. GUI also indicates battery charging, discharging and load connected to panel. Maximum Power Point Tracking (MPPT) is used to extract the maximum power from Solar panel and force the panel to operate at required power.

This paper presents a careful evaluation among the most usual MPPT techniques, doing meaningful comparisons with respect to the amount of energy extracted from the photovoltaic (PV) panel, PV voltage ripple, dynamic response and use of sensors, considering that the models are first implemented via MatLab/Simulink®, and after a digitally controlled boost DC-DC converter was implemented and connected to an Agilent Solar Array simulator in order to verify the simulation results. The prototype was built, the algorithms are digitally developed and the main experimental results are also presented, including dynamic responses and the experimental tracking factor (TF) for the analyzed MPPT techniques.

Maximum Power Point Tracking (MPPT) algorithm is widely used control technique that varies the electrical operating point to extract maximum power available from the solar cell of photovoltaic (PV) module. Since the solar cells have nonlinear i-v characteristics, the efficiency of PV module is very low and power output depends on solar insolation level and ambient temperature. Moreover there is a great loss of power due to mismatch of source and load. So, to extract maximum power from solar panel a MPPT needs to be designed and the objective of the paper is about a novel cost effective and efficient microcontroller based MPPT system for solar voltaic system to ensure fast maximum power point operation at all fast changing environmental conditions. The proposed controller scheme utilizes PWM techniques to regulate the output power of boost converter at its maximum possible value and simultaneously controls the charging process of battery. Parameter extraction, model evaluation and analysis of boost converter is demonstrated using MATLAB/Simulink model.

### 3. RESEARCH METHODOLOGY

Although a simple and effective prototype of a solar-tracking system was implemented, several improvements can be done on it in future works to make it even better.

1. Incorporating sensors at the back of the panel mounting so as to detect sunlight during sunrise and sunset. With a few modifications to the algorithm, the solar tracking system can be made to turn off at sunset and turn-on at sunrise. This can effectively decrease the power consumption of the solar tracking system making it even more efficient.
2. Improving the design of the mounting and use steel which is strong enough to support more weight and can be made smaller, in order to allow more freedom of movement of the panel.

The Block diagram of proposed system is shown in Fig.1. When a direct connection is carried out between the source and load, the output of PV module is seldom maximum and the operating point is not optimal. To overcome this problem it is necessary to add an adaption device, an MPPT controller with a converter between source and load. The Pulse width (PWM) generator is required to maintain the switching mechanism because only when the desired output of current is attained then only the battery should be allowed to charge.

The aim in designing Maximum power point controller is to find the voltage and current at which a Photovoltaic array operates to obtain maximum power under the given temperature and irradiance. Practically we have multiple local maxima, but overall there should be only one true MPP(Maximum power point. To find the optimal point and improve the efficiency of energy conversion we have done a controller design and verified its performance on the MPPT algorithms. The solar energy absorbed by the photovoltaic panel does not always generate a fixed output so a regulator should be connected before charging the battery. A voltage regulator is designed to automatically maintain a constant voltage level.

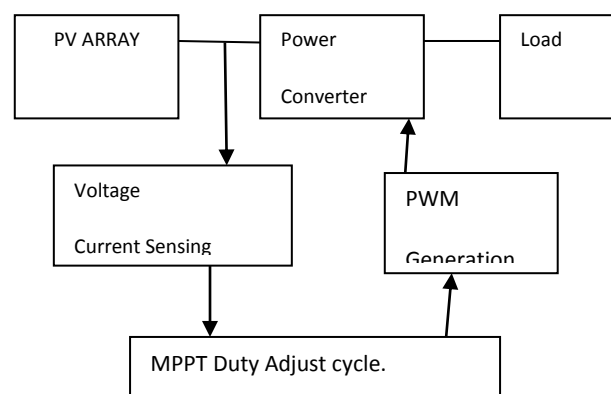

Figure1. Block Diagram of proposed system

The best power that the panel can put out to charge the battery. The design of the simulation model of the proposed system is carried in simulink environment and it requires a physical to real time interface circuit for connecting the panel output as the input to controller circuit. The Pulse width modulation technique is employed in the controller design to achieve the output at highly varying switching speeds. The solar chargers use technology similar to other high quality battery chargers. When a battery reaches the regulation set point the PWM algorithm slowly reduces the charging current to return maximum amount of energy to the battery in the shortest time, that result in achieving a higher charging efficiency.

#### 4. SIMULATION WITH MATLAB

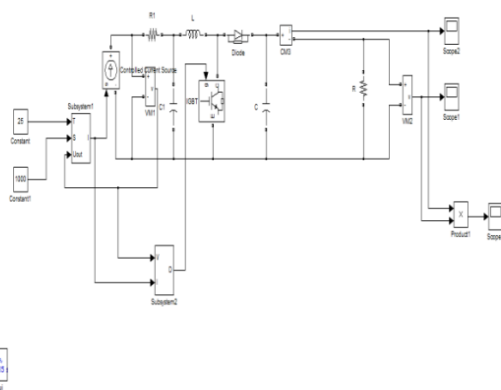

Figure 2: Simulation diagram for improving the efficiency of the solar photovoltaic based operated system.

The given MATLAB model shows us proposed system for improving the efficiency of the system.

#### 4.1 Result:

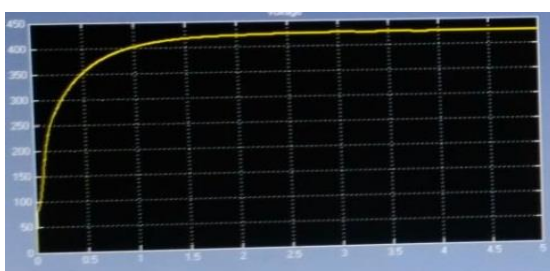

Figure 3: output before implementation of the proposed work.

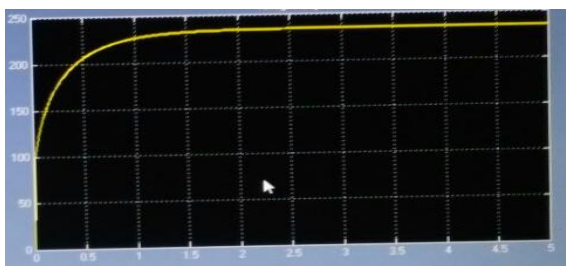

Figure 4: output obtained after implementation of the proposed work

After comparing both the outputs it is clear that the efficiency of the output is relatively constant for a longer period of time after implementation of the proposed system. It also increases its efficiency by more than 50% which the shows that the system is successful in achieving its target accordingly.

#### 5. CONCLUSION

The intensive use of energy from the solar cell is essential for providing solutions to environmental problems like pollution and global warming. The Implementation of Maximum power point controller through normal digital controllers would be easier if it is possible to minimize error functions. For a particular application, selecting a particular MPP Technique is a tough task and this paper will be a good reference for the researchers as we have compared the algorithms with working models in real time. As the position of sun keeps changing in the day the angle of incidence changes hence we proposed a model to rotate the panel to improve the angle of incidence for considering the optimal MPP point even under shaded and unshaded conditions.

#### 6. REFERENCES

- [1]Seok-II Go,Seon-JuAhu,Joon-Ho Choi,"Simulation and analysis of Existing MPPT Control methods in a PV Generation System", journal of international Council on Electrical Engineering.,v01.1,Issue 4,pp 446-451,2011.
- [2] MdFahim Ansari,S.Chatterji,AtifIqbal,"A Fuzzy logic control scheme for a solar photovoltaic system for a maximum power point tracker",international Journal of Sustainable Energy.,vol.29 Issue 6,pp 245-255,December 2010.
- [3] R.Leyva,P.Artillan,,"Dynamic performance of maximum power point tracking circuits using sinusoidal extremum seeking control for hotovoltaic generation", international Journal ofElectronics.,vol.98,Issue 4,pp 529-542,april2011.
- [4] C.larbes,S.M.AitCheikh,T.Obeidi,AZerguerras "Genetic algorithms optimized fuzzy logic control for the maximum power point tracking in photovoltaic system",Elsevier, Renewable energy.,vol.34.pp2093-2100,2009.
- [5] Joe-Air Jiang,Tsong-Liang Huang,Ying-Tung Hsiao,Chia-Hong Chen," Maximum Power tracking for Photovoltaic power systems", Tamkang journal of science and enginerring., vol 8,Issue 2,pp 147-153,2005.
- [6] ADolaro,R.Faranda,S.Leva,"Energy Comparision of seven MPPT techniques for PV systems",IElectromagneticAnalysis&Applications,Scientific Research,online(www.SciRP.org/journal).2009.3:152-162&Applications,ScientificResearch,online(www.SciRP.org/journal).2009.3:152-162.

[7]Hairul Nissah Zainudin, Saad Mekhilef," Comparison study of maximum power point tracker techniques for PV systems", Proceedings of the 14th International Middle east power systems Conference, Cairo university, Egypt, December 19-21,2011.

[8] ESRAM and P.L.Chapman, "Comparison of Photovoltaic array maximum Power Point Tracking Techniques," IEEE Trans. Energy Conv., vol.22,pp.439-449,2011.

## BIOGRAPHY



Ms. Ayushi Wasnik

She has completed B.E (Electrical Eng)  
From A.G.P.C.E, Nagpur, She is M.Tech  
(Integrated (Integrated Power System)  
From A.G.P.C.E A.G.P.C.E.