

# Fault Detection and Analysis of three-phase induction motors using MATLAB Simulink model

Ketan P. Diwatelwar<sup>1</sup>, Soniya K. Malode<sup>2</sup>

<sup>1</sup>PG Scholar, Electrical Engineering Department, Shri Sai College of Engineering & Technology, Bhadrawati

<sup>2</sup>Head of Department, Electrical Engineering Department, Shri Sai College of Engineering & Technology, Bhadrawati, Maharashtra, India

\*\*\*

**Abstract** - Computer simulation of electrical motor operation is especially helpful for gaining an insight into their dynamic behavior and electro-mechanical interaction. An acceptable model permits motor faults to be simulated and therefore the amendment in corresponding parameters to be expected while not physical experimentation. This planned approach presents each a theoretical and experimental analysis of uneven stator coil winding and rotor faults in induction machines. A three-phase induction motor was simulated and operated below traditional healthy operation, with section to section winding fault, section to ground winding fault and short circuit winding fault and with voltage imbalances between phases of offer. The results illustrate sensible agreement between each simulated and experimental results.

For analysis of fault condition typical methodology of quick Fourier transform area unit initial use and take a look at for various winding fault conditions. Then fuzzy logic controller supported fuzzy rule base style for analysis of stator coil winding faults. From each the conditions it clear that the FFT analysis solely calibrate total harmonics distortion (THD) of faulted voltage and current signal of 3 section induction motor input facet (stator side). Whereas fuzzy logic controller directly analyzed the sort of the fault on induction motor stator coil winding.

Motor model and fault analysis system style in MATLAB 2015 Simulink computer code. Victimization this computer code, motor parameter analysis, fault cases analyzed.

**Key Words:** Induction motor fault analysis, fuzzy logic control

## 1. INTRODUCTION

Induction motors square measure essential parts in several industrial processes. In spite of their strength they are doing often fail and their ensuing unplanned period of time will prove terribly expensive. Therefore, condition observance of electrical machines has received considerable attention in recent years. There square measure some ways to find mechanical and electrical issues in induction motors, either directly or indirectly. Directly, several parameters may be monitored to produce helpful indications of early faults. These parameters embrace case vibration and noise, mechanical device section current, air-gap or external magnetic concentration. Hargis et al. showed that

mechanical defects square measure detectable through variations within the vibration of the mechanical device core [1-6]. It's been prompt by Steele that per-phase current observance will give similar indications.

The advantages of per-phase current observance area unit foremost, it's simple to measure; second, the fault patterns within the current signal area unit distinctive and third, associate estimation of the amount of broken bars will be made up of the analysis [7-12]. Stephan et al. [13] used air-gap search coils to sight and estimate each the peripheral and radial element of the leak flux. Associate axial flux sensing methodology to sight rotor short circuits and alternative malfunctions has additionally been represented by journalist et al. [14]. Indirectly, modeling Induction motors area unit crucial parts in several industrial processes. In spite of their strength they are doing sometimes fail and their ensuing unplanned period of time will prove terribly expensive. Therefore, condition observance of electrical machines has received goodly attention in recent years. There area unit some ways to sight mechanical and electrical issues in induction motors, either directly or indirectly. Directly, several parameters will be monitored to supply helpful indications of inchoate faults. These parameters embrace case vibration and noise, mechanical device section current, air-gap or external magnetic denseness. Hargis et al. showed that mechanical defects area unit detectable through variations within the vibration of the mechanical device core [1-6]. it's been urged by Sir Richrd Steele that per-phase current observance will offer similar indications.

The advantages of per-phase current observance area unit foremost, it's simple to measure; second, the fault patterns within the current signal area unit distinctive and third, associate estimation of the amount of broken bars will be made up of the analysis [7-12]. Stephan et al. [13] used air-gap search coils to sight and estimate each the peripheral and radial element of the leak flux. associate axial flux sensing methodology to sight rotor short circuits and alternative malfunctions has additionally been represented by journalist et al. [14]. Indirectly, modeling.

## 2. PROPOSED METHODOLOGY

### 2.1. Fast Fourier Transform Approach

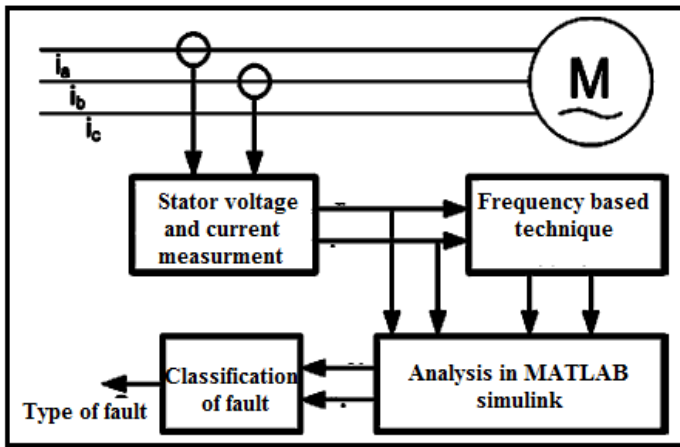


Fig -1: Generalized block diagram of FFT analysis

Figure 1 shows the FFT approach for three phase induction motor analysis or harmonics analysis. In these approach first three phase induction motor input voltage and input current are measured using CTs and PTs. Then measures RMS three phase voltage and current signal send to FFT analysis blocks. In this section total harmonics content was analyzed for normal condition and also for abnormal winding faults conditions. By observing the harmonics contents in normal condition and abnormal condition we analyzed the total Harmonics distortion (THD) of each three phase voltage and three phases current.

From analysis it is clear that harmonics content during normal condition is minimum for both three phase voltage and three phase current signal. But this condition true only for few fault condition not satisfy for all conditions. For identify all winding faults condition of three phase induction motor.

### 2.2. Fuzzy Logic Controller Approach

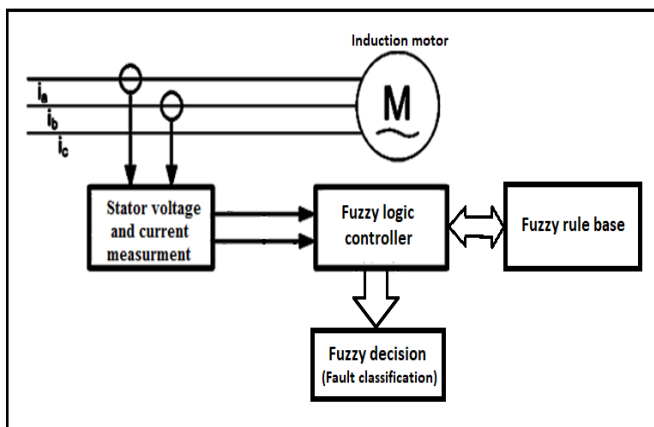


Fig-2: Generalized block diagram of fuzzy logic controller based approach

Figure 5.2 shows the fuzzy logic controller based three phase induction motor fault classification. In these approach first three phase induction motor input voltage and input current are measured using CTs and PTs. Fuzzy rule base design for fuzzy logic controller system, for that purpose three phase induction motor operate on normal condition and different fault conditions. Based on reading of three phase voltage and current, rules are design for normal, phase to phase winding fault, phase to ground winding fault and short circuit fault. Then after fuzzy logic controller places after three phase voltage and current measurement system.

### 3. MATLAB Simulation model

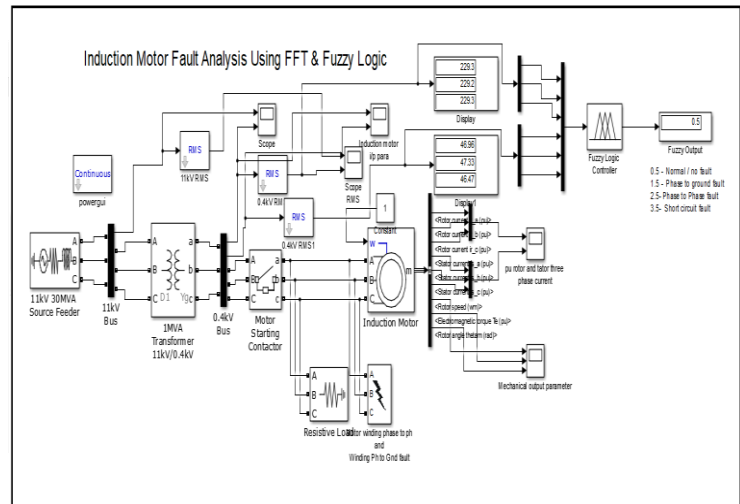


Fig -3: MATLAB simulation model of proposed approach

Sr No	Name of simulation block	Parameter specification
1	11KV, 30MVA, Source feeder	Phase to phase RMS voltage = 11 KV; Frequency = 50Hz; Three phase short circuit level at base voltage = 30 MVA; Base voltage = 11 KV; X/R Ratio = 7
2	1 MVA Transformer	Primary winding connection = Delta; Secondary winding connection = Star with earth grounded; Nominal power = 1 MVA; Frequency = 50Hz; Primary winding voltage = 11KV; Secondary winding voltage = 0.4 KV; Primary and secondary winding resistance = 0.002 Pu; Primary and secondary winding inductance = 0.08 pu; Magnetizing resistance and inductance = 500pu
3	Motor starting contractor	Initial status of breaker = open; Switching time = 0.1 Sec; Breaker resistance Ron = 0.001 Ohm; Snubber resistance = 1 Mega Ohm
4	Induction motor	Rotor type = Squirrel cage; motor model: 100HP; Power = 75 KW; V = 400V; speed = 1484 RPM; Nominal power = 75 KVA; Vn = 400 V; Frequency = 50Hz; Stator resistance = 0.01665 pu; Stator inductance = 0.04955pu; Rotor resistance Rr = 0.009805pu; Rotor inductance Rl = 0.04988pu; Mutual inductance Lm = 2.224pu; Pole pair = 2

## 4. MATLAB SIMULATION RESULTS

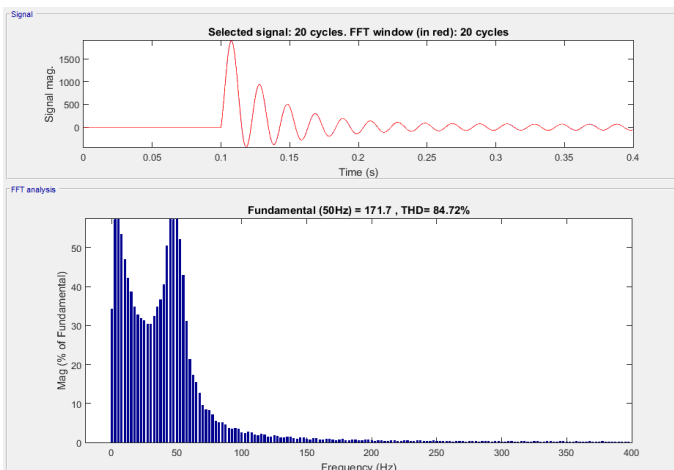
### 4.1. Results from Fast Fourier Transform

**Table-1:** FFT Analysis result for calibration of Total Harmonics Distortion (THD)

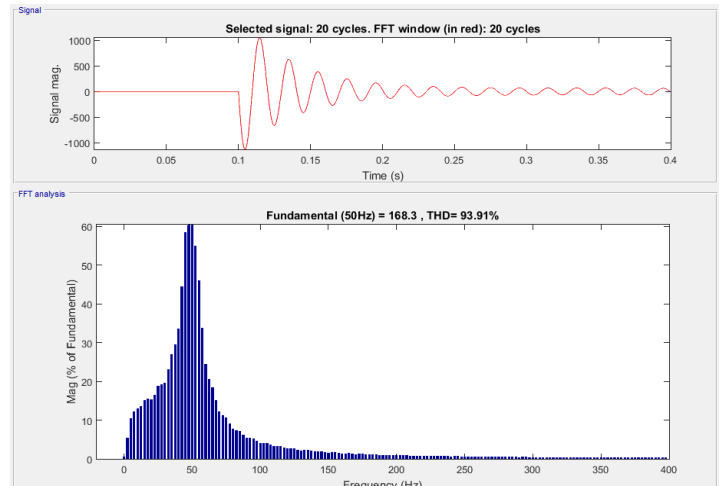
Sr No	Fault type	Total Harmonics Distortion (THD) %					
		Va	Vb	Vc	Ia	Ib	Ic
1	Normal	1.7	1.93	1.55	84.72	93.91	84.81
2	Ph-Gnd (A-G)	53.21	2.06	2.17	64.02	101.97	48.43
3	Ph-Gnd (B-G)	2.37	55.47	1.7	51.29	66.43	90.55
4	Ph-Gnd (C-G)	1.78	2.51	50.75	91.9	51.08	68.02
5	Ph-Ph (A-B)	46.68	49.31	2.14	63.81	63.56	48.99
6	Ph-Ph (B-C)	2.23	46.69	48.95	46.57	66.06	66.28
7	Ph-Ph (A-C)	45.34	2.445	43.1	65.59	48.02	66.15
8	Three phase short circuit	68.32	73.65	68.17	64.38	64.55	66.8

Table 1 shows the Total harmonics distortion calibration using FFT analysis. From above table it is clear that during normal condition of three phase induction motor THD for three phase voltage is below 2% and three phase current THD is in between 80 to 95%. For abnormal condition total harmonics distortion for faulted phases was increases that means harmonics content increases in faulted phase.

#### 4.1.1. Normal condition

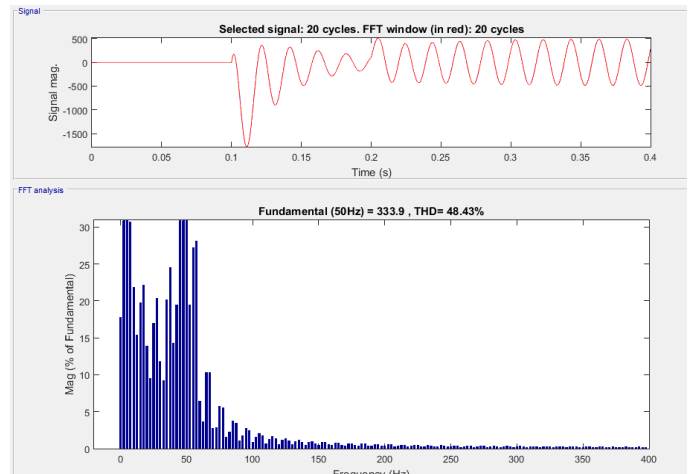


**Fig-4:** FFT Analysis on phase A current signal during normal condition

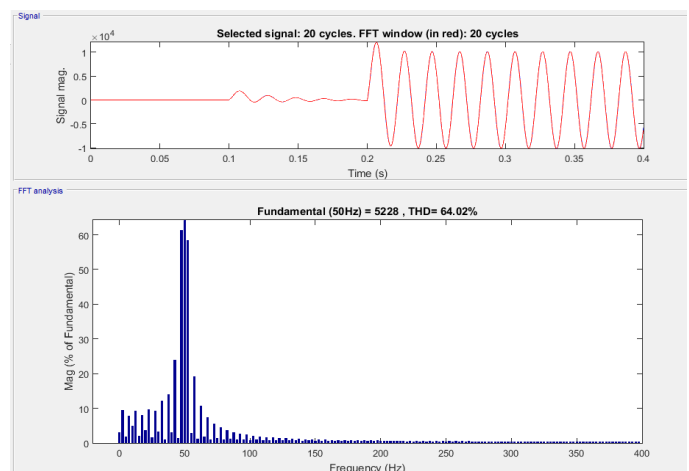


**Fig-5:** FFT Analysis on phase B current signal during normal condition

#### 4.1.2. Phase to ground winding fault

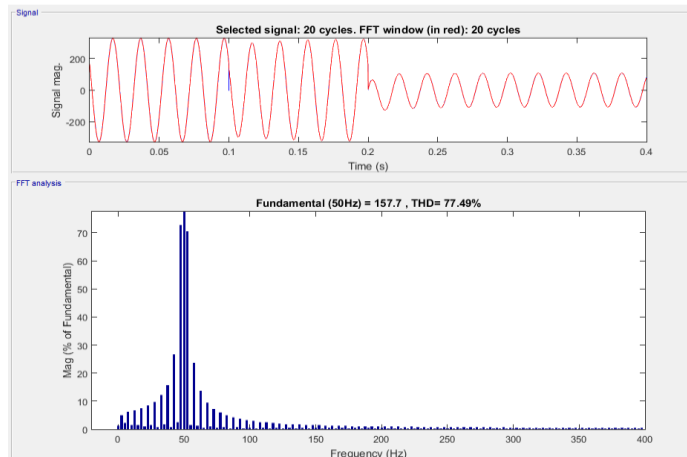


**Fig-6:** FFT Analysis on phase A current of induction motor during phase to ground fault in phase A winding to Ground

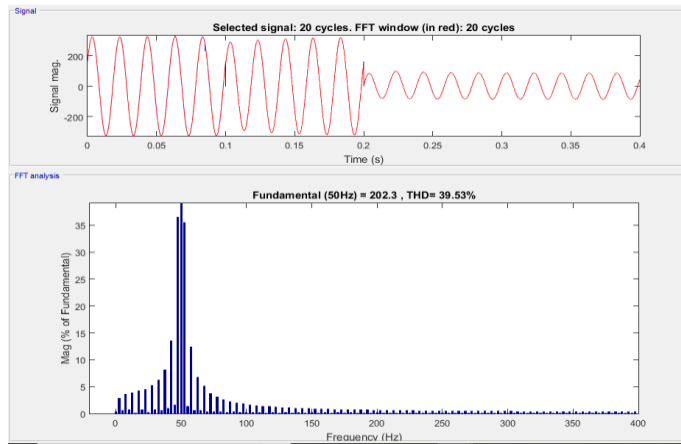


**Fig-7:** FFT Analysis on phase C current of induction motor during phase to ground fault in phase A winding to Ground

### 4.1.3. Phase to phase winding fault

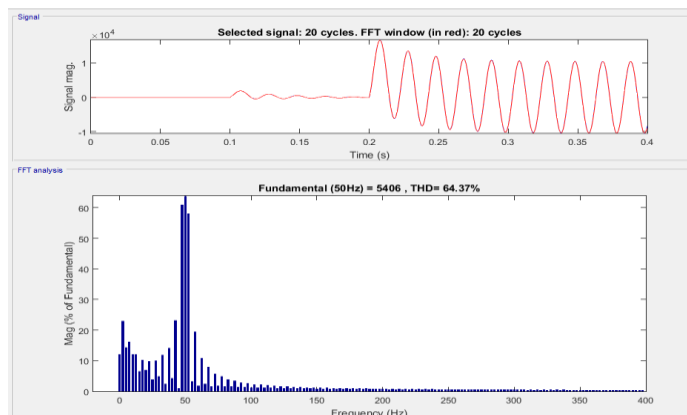


**Fig-8:** FFT Analysis on phase C Voltage of induction motor during phase to Phase fault in phase A winding to C Winding

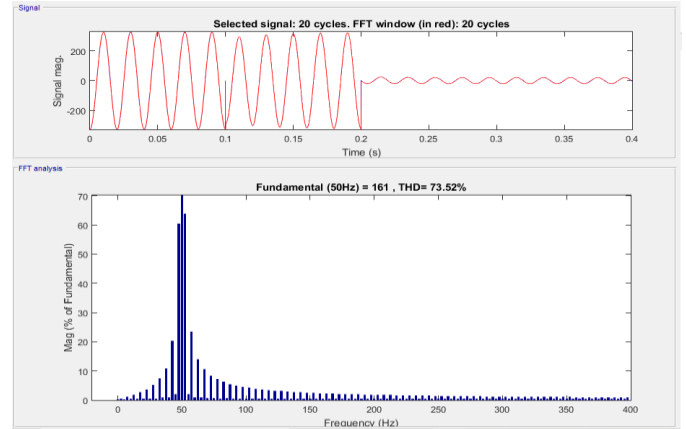


**Fig-9:** FFT Analysis on phase A voltage of induction motor during phase to Phase fault in phase A winding to C Winding

### 4.1.4. Three Phase Short Circuit Winding Fault



**Fig-9:** FFT Analysis on phase A Current of induction motor during three phase short circuit in stator winding

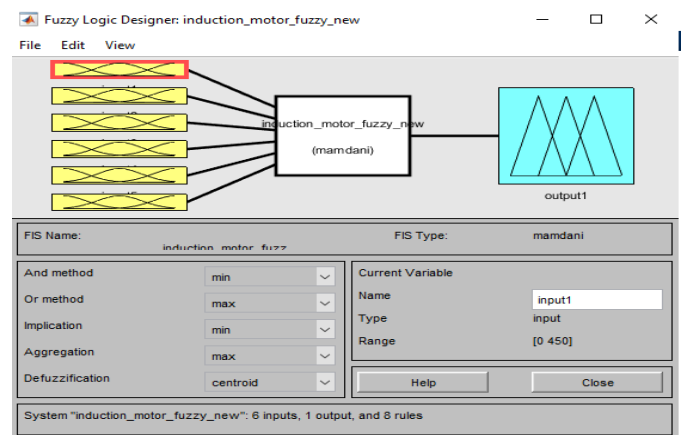


**Fig-10:** FFT Analysis on phase B Voltage of induction motor during three phase short circuit in stator winding

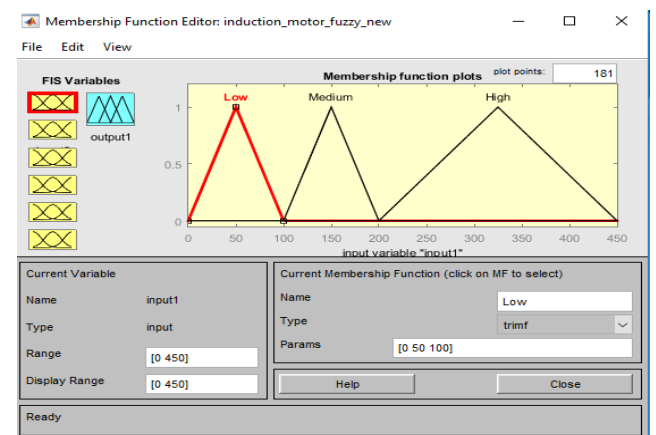
Figure 4 to 10 shows the FFT window for calibration of total harmonics distortion (THD) for normal and abnormal faults conditions on three phase induction motor.

## 4.2. Results from Fuzzy Logic Control

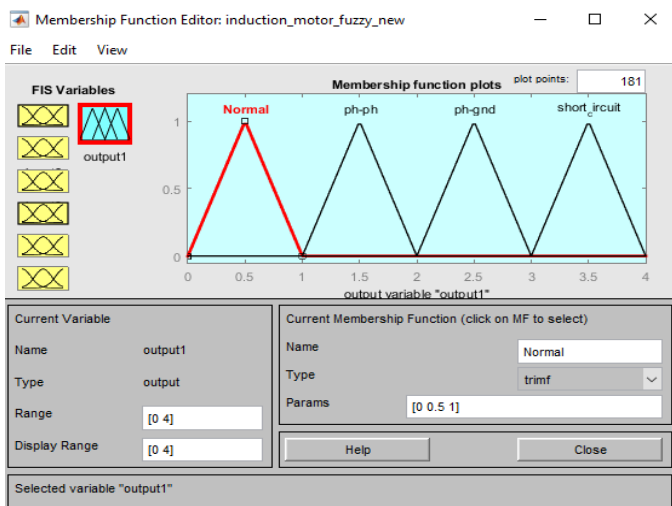
### 4.2.1. Fuzzy Logic controller



**Fig-11:** Fuzzy logic controller designing toolbox in MATLAB simulink for induction motor fault analysis



**Fig-12:** Membership function for three phase stator input voltage



**Fig-13:** Membership function for fuzzy decision for three phase induction motor fault classification

**Table-3:** Fuzzy Rule and corresponding fuzzy decision

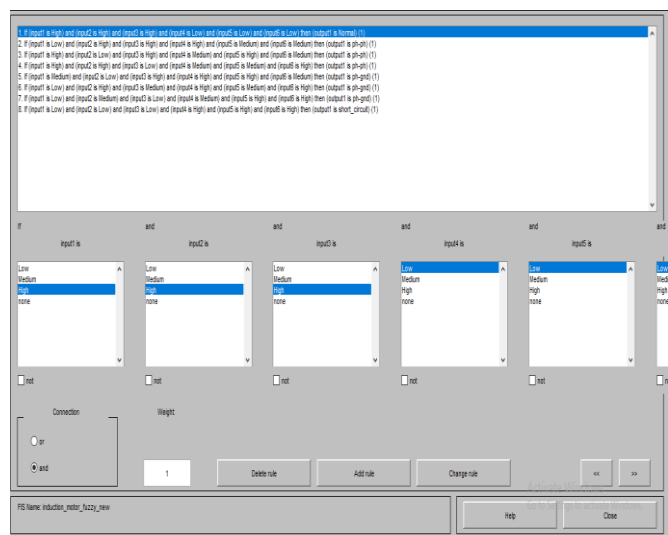
Sr No	Va	Vb	Vc	Ia	Ib	Ic	ph-ph	ph-gnd	short circuit	normal
1	H	H	H	L	L	L	0	0	0	1
2	L	H	H	H	M	M	2	0	0	0
3	H	L	H	M	H	M	2	0	0	0
4	H	H	L	M	M	H	2	0	0	0
5	M	L	H	H	H	M	0	3	0	0
6	L	H	M	H	M	H	0	3	0	0
7	L	M	L	M	H	H	0	3	0	0
8	L	L	L	H	H	H	0	0	4	0

Note : H = High = Range for voltage ( 0 to 100 Volts) and for current (0 to 50 Amperes)

M = Medium = Range for voltage ( 100 to 200 Volts) and for current ( 50 to 3725 Amperes)

L = Low = Range for voltage (200 to 450 Volts) and for current (3725 to 7500 Amperes)

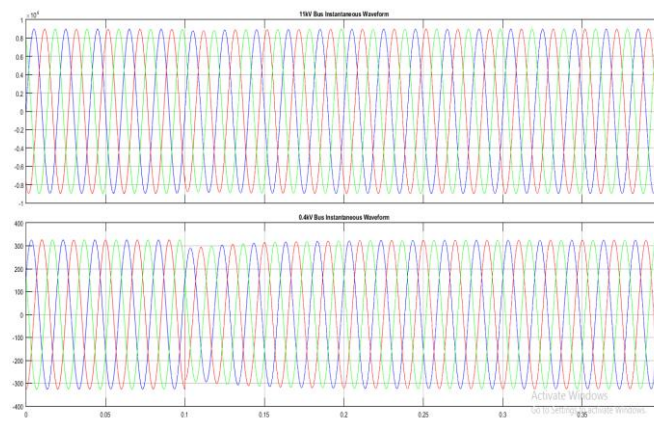
**4.3. Result for three phase induction motor**



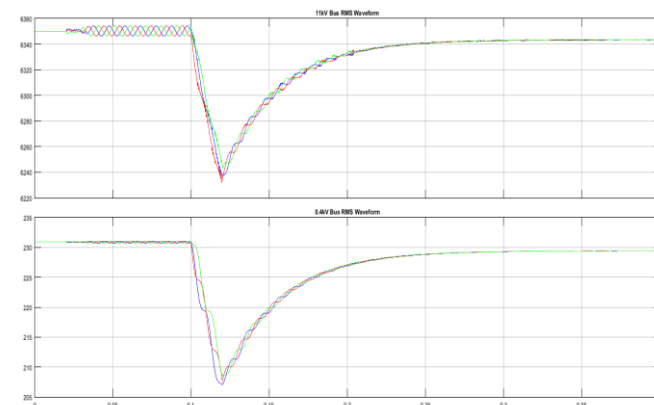
**Fig-14:** Fuzzy rule base for fuzzy logic controller

**Table-2:** Three phase stator current and voltage for different fault condition and normal condition

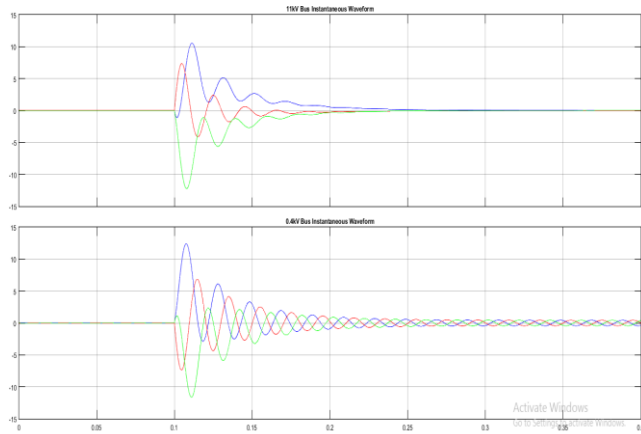
Sr No	Faults	Fault Type	Va	Vb	Vc	Ia	Ib	Ic
1	Normal	Normal	229.4	229.4	229.4	47.51	47.48	47.52
2	AG	Wgd ph-Gn	89.24	220	218.7	7174	313.3	345.1
3	BG	Wgd ph-Gn	218.8	89.24	220	345.2	7174	313.3
4	CG	Wgd ph-Gn	220	218.7	89.24	313.5	345.1	7174
5	AB	Wdg ph-ph	120.8	94.51	215.3	6459	6396	521.8
6	BC	Wdg ph-ph	215.2	120.8	94.5	522	6457	6393
7	AC	Wdg ph-ph	94.47	215.2	120.7	6395	522.1	6458
8	ABC	Wdg ph-ph	14.83	14.81	14.79	7410	7403	7399
9	ABCG	Wgd ph-Gn	14.83	14.8	14.8	7412	7402	7397



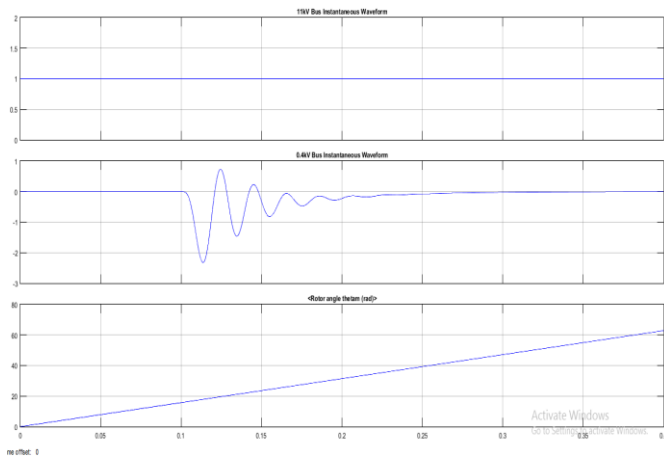
**Fig-4:** Three phase induction motor input three phase voltage and current



**Fig-5:** Three phase RMS 11kv bus bar voltage and 0.4KV RMS bus bar voltage



**Fig-6:** Three phase induction motor rotor three phase PU current and PU stator current



**Fig-7:** Rotor speed, electromechanical torque and rotor angle

**Table-4:** Comparison of FFT and Fuzzy Logic control technique

Sr No	FFT Analysis	Fuzzy Logic control Technique
1	FFT analyzed frequency components of input voltage and current of stator.	Not analyzed frequency of three phase stator voltage and current
2	Not classify type of fault occurs in machine	Exactly classify each type of fault in three phase induction motor
3	Time required for analysis is more	Time require for classification in very less.
4	Complex analysis	Easy analysis
5	Not generalization for different machines	Generalization of rule base system design for any machine protection

### 5. CONCLUSION

FFT analysis only analyzed total harmonics distortion of stator input voltage and current. FFT Analysis takes more time for analysis of fault condition. It requires to analyze each phase voltage and current THD.

Fuzzy logic controller rule base system easily classifies each type of three phase induction motor fault conditions. Fuzzy logic controllers classify the fault with the short duration of time as compared with FFT analysis technique. Efficiency of fuzzy logic controller as compared with FFT analysis for three phase induction motor fault classification is more.

As a possible extension to this work, it would be quite useful to analyze all fault conditions for synchronous machine. Also extend for DC motor drive fault analysis and Brushless DC motor drive fault classification.

### REFERENCES

[1] Tavner PJ, Penman J (1987) Condition monitoring of electrical machines. Research Studies Press Ltd., Hertfordshire, England. ISBN 0863800610

[2] Bonnet AH, Soukup GC (1992) Cause and analysis of stator and rotor failures in three phase squirrel cage induction motors. IEEE Trans Ind Appl 28(4):921-937

[3] Deleroi W (1984) Broken bars in squirrel cage rotor of an induction motor-part I: description by superimposed fault currents. Arch Elektrotech 67:91-99

[4] Filippetti F, Franceschini G, Tassoni C, Vas P (1998) AI techniques in induction machines diagnosis including the speed ripple effect. IEEE Trans Ind Appl 34:98-108

[5] Bellini A, Concari C, Franceschini G, Lorenzani E, Tassoni C, Toscani A (2006) Thorough understanding and experimental validation of current sideband components in induction machines rotor monitoring. In: IECON 2006-32nd annual conference on IEEE industrial electronics, pp 4957-4962

[18] Bonnett Austin H, Soukup GC (1992) Cause and analysis of stator and rotor failures in three phase squirrel-cage induction motors. IEEE Trans Ind Appl 28(4):921-937

[19] Dorrell DG, Thomson WT, Roach S (1997) Analysis of air-gap flux, current and vibration signals as function of a combination of static and dynamic eccentricity in 3-phase induction motors. IEEE Trans Ind Appl 33:24-34

[20] Bradford M (1968) Unbalanced magnetic pull in a 6-pole induction motor. IEEE Proc Electr Eng 115(11):1619-1627

[21] M'hamed D, Cardoso AJM (2008) Air gap eccentricity fault diagnosis in three phase induction

motor by the complex apparent power signature analysis. *IEEE Trans Ind Electr* 55(3):1404

[22] Hwang DH, Lee KC, Lee JH, Kang DS, Lee JH, Choi KH, Kang S et al (2005) Analysis of a three phase induction motor under eccentricity condition. In: 31st annual conference of IEEE industrial electronics society, IECON2005, pp 6–10

[23] Eschmann P, Hasbargen L, Weigand K (1958) Ball and roller bearings: their theory, design and application. K. G. Heyden, London

[24] Schoen RR, Habetler TG, Kamran F, Bartheld RG (1995) Motor bearing damage detection using stator current monitoring. *IEEE Trans Ind Appl* 31(6):1274–1279

[25] Siddique A, Yadava GS, Singh B (2005) A review of stator fault monitoring techniques of induction motors. *IEEE Trans Energy Convers* 20(1):106–114

[26] Lee SB, Tallam RM, Habetler TG (2003) A robust on-line turn-fault detection technique for induction machines based on monitoring the sequence component impedance matrix. *IEEE Trans Power Electr* 18(3):865–872

[27] Vatsa, A. (2017). Fault diagnosis of induction motor using wavelets. *International Journal of Research and Engineering*, 4(4), 125-129.

[28] Altaf, S., Soomro, M. W., & Mehmood, M. S. (2017). Fault Diagnosis and Detection in Industrial Motor Network Environment Using Knowledge-Level Modelling Technique. *Modelling and Simulation in Engineering*, 2017.

[29] Benbouzid, M. E. H., Vieira, M., & Theys, C. (1999). Induction motors' faults detection and localization using stator current advanced signal processing techniques. *IEEE Transactions on power electronics*, 14(1), 14-22.