

# Multilevel Inverter Based Three Phase Induction Motor Drive

Adarsh A. Kale<sup>1</sup>, Soniya K. Malode<sup>2</sup>

<sup>1</sup>PG Scholar, Electrical Engineering Department, Shri Sai College of Engineering & Technology, Bhadrawati Maharashtra, India,

<sup>2</sup>Head of Department, Electrical Engineering Department, Shri Sai College of Engineering & Technology, Bhadrawati Maharashtra, India.

\*\*\*

**Abstract** - High power induction motor drives victimization classical three-phase converters have the disadvantage of poor voltage and current qualities. To boost these values, the switch frequency has got to be raised that causes extra switch losses. Another chance is to place a motor input filter between the device and motor, that causes extra weight. An additional inconvenience is that the restricted voltage which will be applied to the induction motor determined by the obstruction voltage of the semiconductor switches. For top power semiconductors, the switch frequency is restricted by the largest power loss. During this methodology, a three-phase induction motor device is represented.

A new device topology for drives is conferred during this methodology: a three-phase construction device with on an individual basis regulated dc power provides. The dc voltages square measure provided by star pv system, turbine system. The applications for the device square measure particularly high-energy traction systems, wherever the voltage applied to the induction motor is greater than one kilovolt and for coupling of induction motor with DC supply and non-conventional energy sources while not fluctuation of power. The motor current is of a really prime quality, compared to a classical three-phase device. This permits keeping the switch frequency low by victimization phase-shifted pulse-width modulation (PWM) carriers

**Key Words:** Series Active Power Fault (SAPF), Power quality improvement

## 1. INTRODUCTION

Electrical Energy already constitutes quite half-hour of all energy usage on Earth. And this is often set to rise within the returning years. Its huge quality has been caused by its potency of use, simple transportation, simple generation, and environment-friendliness. A part of the full current production is sued to provide heat, light, in electrolysis, arc-furnaces, domestic heating etc. Another massive part of the current production is employed to be reborn into energy via completely different styles of electrical motors- DC Motors, Synchronous Motors and Induction Motors. Induction Motors square measure typically termed the "Workhorse of the Industry". This is often as a result of it's one among the foremost wide used motors within the world. It's employed in transportation and industries, and conjointly in family appliances, and laboratories. The main reasons behind the recognition of the Induction Motors are:

- i. Induction Motors square measure low-cost compared to DC and Synchronous Motors. During this age of competition, this is often a chief demand for any machine. Attributable to its economy of procurance, installation and use, the Induction Motor is sometimes the primary selection for associate operation.
- ii. Squirrel-Cage Induction Motors square measure terribly rugged in construction. Their lustiness allows them to be employed in all types of environments and for long durations of your time.
- iii. Induction Motors have high potency of energy conversion. conjointly they're terribly reliable.
- iv. Because of their simplicity of construction, Induction Motors have terribly low maintenance prices.
- v. Induction Motors have terribly high beginning force. This property is beneficial in applications wherever the load is applied before beginning the motor.

Another major advantage of the Induction Motor over alternative motors is that the ease with that its speed will be controlled. Applications need different optimum speeds for the motor to run at. Speed management may be a necessity in Induction Motors attributable to the subsequent factors:

- i. It ensures swish operation.
- ii. It provides force management and acceleration management.
- iii. Processes need the motor to run at different speeds.
- iv. It compensates for unsteady method parameters.
- vi. throughout installation, slow running of the motors is needed.

All these factors gift a powerful case for the implementation of speed management or variable speed drives in Induction Motors.

## 2. PROPOSED METHODOLOGY

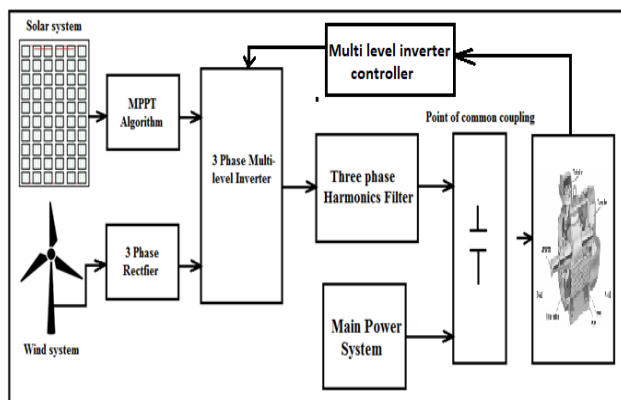
### 2.1. Project Implementation

This project implementation will be done using MATLAB 2015 Simulink software. The major blocks will be design in MATLAB simulink as follows:

- Simulation of power system using simpower system toolbox.
- Simulation of three phase induction motor using sim power system toolbox.
- Simulation of three phase multilevel inverter circuit using power electronics toolbox.
- Simulation of DC input power supply (solar, battery or DC generator) for input simulation of multilevel inverter circuit.

### 2.2. Main system

Combined wind-PV hybrid generation system utilizes the solar and wind resources for electric power generation. Individual wind and solar renewable sources have unpredictable random behavior. As throughout the day solar energy is present but due to the sun intensity and unpredictable shadows by the clouds, birds, trees etc the solar irradiation levels varies. Due to this cause solar energy is unreliable and less used.



**Fig-1:** Generalized block diagram of proposed multilevel inverter based solar wind induction motor drive system

Wind is a form of solar energy. Due to the uneven heating of the atmosphere by the sun wind flow. Due to the earth terrains, bodies of water and vegetation the wind flow patterns are modified. Wind turbine converts the kinetic energy in the wind in to mechanical then to electrical by rotating the generator which are connected internally. Wind is highly unpredictable in nature as it can be here one moment and gone in another moment but it is capable of supplying large amount of power. Due to this concept of wind energy it is an unreliable one and less used.

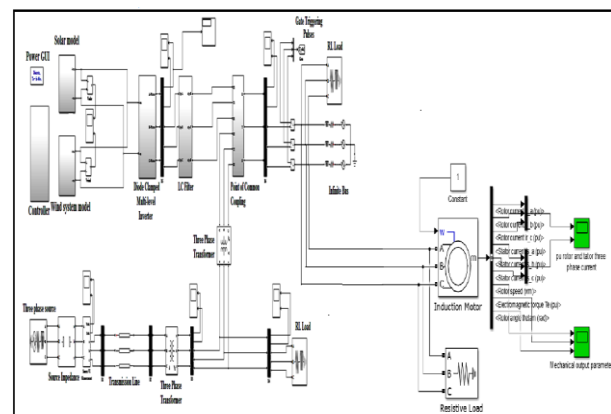
So it is better to use hybrid generation system which is better than individual wind or individual PV generation system. So it is overcome the demerits of individual system. Grid interface of hybrid generation system improves the system reliability.

In this system there is a wind turbine, the output of the wind turbine goes to permanent magnet synchronous generator. The output of the wind system is in ac so we need ac to dc converter to convert the ac output in to dc. Similarly in the PV side the output of the PV array is connected with a dc-dc boost converter to rise the output voltage up to a desire level. And the output of PV and wind are connected with a common DC link voltage. The common DC link voltage will be connected with the DC to AC converter and the output of the inverter is synchronizing with grid. This inverter changes DC power from PV array and the wind turbine into AC power and it maintain the voltage and frequency is equal to the grid voltage and frequency.

A standalone PV or wind power system is not able to provide sufficient power to the load connected due to intermittent energy source. To accommodate every requirement of energy and providing stabilize output power to the consumers, a hybrid system with energy storage is purpose. The wind turbine power system connects to AC-DC rectifier to convert the AC output into DC output. On the other hand, the PV power system is connected to DC-DC converter to step-up the power generated. Both generated DC output power will be combined at the DC bus at then supply to the loads. Extra energy will be stored into the energy storage system.

Therefore, the overall hybrid system will consists of a wind turbine system, a photovoltaic power system, and power electronic devices such as DC-DC converter, Multilevel inverter and AC-DC rectifier. The purposed hybrid system is illustrated in Figure 1. This hybrid power system implemented using MATLAB simulink software.

### 3. MATLAB SIMULATION MODEL



**Fig-2:** Matlab simulation model of proposed multilevel inverter based induction motor drive

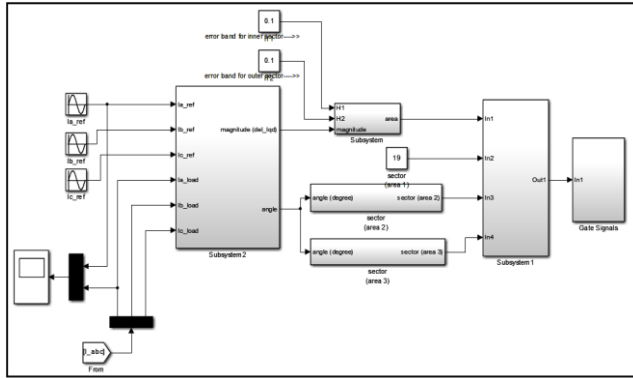


Fig-3: Controller subsystem in MATLAB simulation

Figure 3 shows the multilevel inverter controller subsystem in which gating signal generated for 12 pulse multilevel inverter subsystem from controller subsystem from figure 4. In figure 6.4 the gating signals was separated for each arm IGBT switches arm for individual three phase arm. Figure 4 shows the main controller subsystem for generation of active and reactive current components of power system in which source current and load current i.e. induction motor current was compared with standard three phase ac current. In last step of this system we get magnitude of three phase and phase angle difference between standard three phase current and load current that is depends on loading condition phase angle varies and calibrated at last step of subsystem.

Table-1: Controller subsystem MATLAB simulation model parameter specification

Sr No.	Name of simulation block	Parameter specification of MATLAB block
1.	ia_ref	Sine type = Time based; Time = Use as simulation time; Amplitude = 250; Frequency = $2 * \pi * 50$ rad/sec; Phase = 0 rad; Sample time = 0 sec.
2.	ib_ref	Sine type = Time based; Time = Use as simulation time; Amplitude = 250; Frequency = $2 * \pi * 50$ rad/sec; Phase = $-2 * \pi * 3$ rad; Sample time = 0 sec.
3	ic_ref	Sine type = Time based; Time = Use as simulation time; Amplitude = 250; Frequency = $2 * \pi * 50$ rad/sec; Phase = $+2 * \pi * 3$ rad; Sample time = 0 sec.

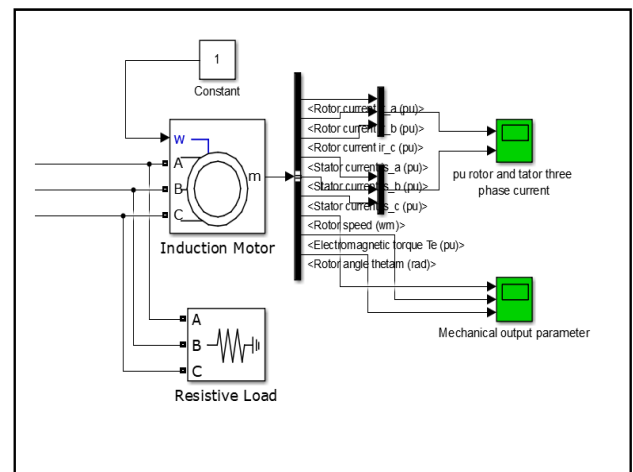


Fig-5: Three phase induction motor MATLAB Simulink model

Table-2: Matlab simulation model parameter specification for three phase induction motor

Sr No	Name of simulation block	Parameter
1	Three phase induction motor (SI unit)	Rotor type : Squirrel cage induction motor 100HP, 75KW, 400V, 50Hz, 1484RPM Nominal power = 75 KW; Line to line voltage = 400 V; Frequency = 50 Hz; Stator resistance $R_s = 0.01665$ Pu; Stator inductance $L_s = 0.04955$ pu; Rotor resistance $R_r = 0.009804$ pu; Rotor Inductance $L_r = 0.04955$ pu; Mutual Inductance $L_m = 2.224$ pu

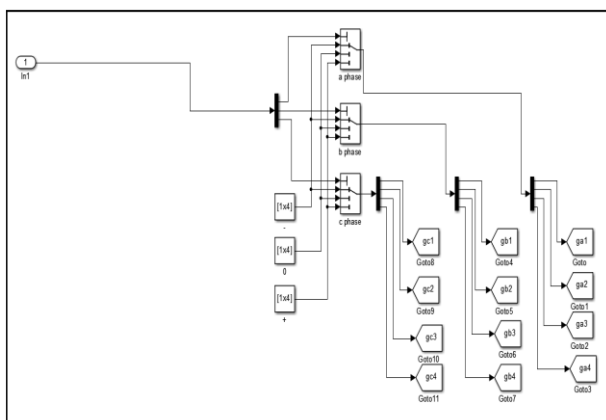
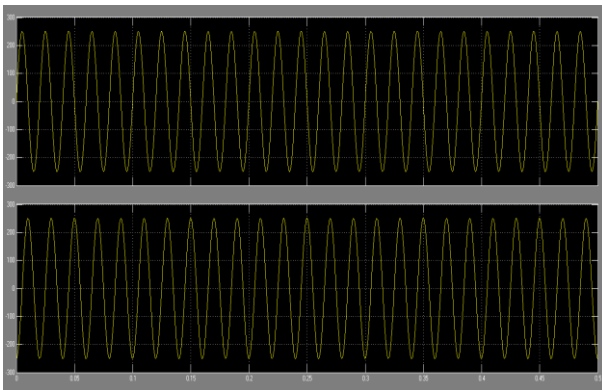


Fig-4: Controller Gate signal generation model in MATLAB Simulink

## 4. MATLAB SIMULATION RESULTS

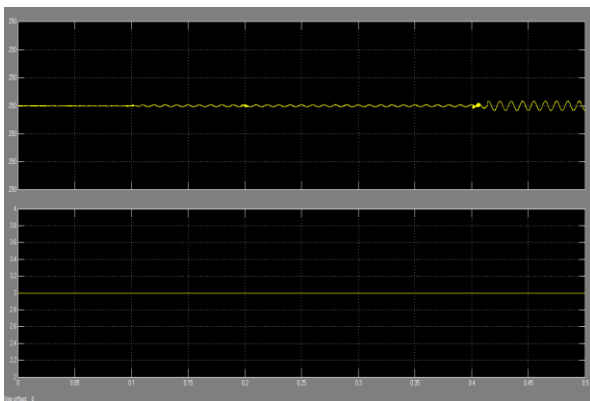
### 4.1. Controller parameters



**Fig-6:** Real and imaginary current signals in controller

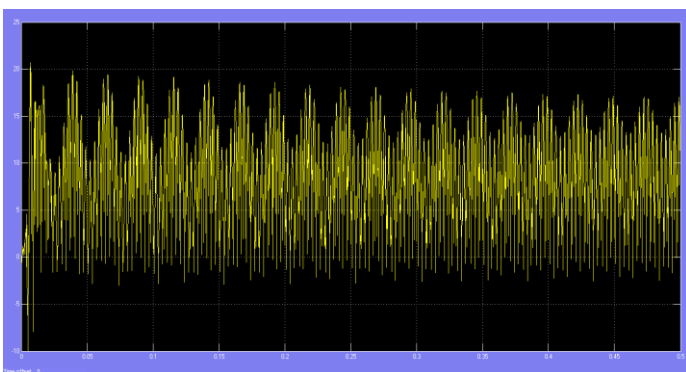
Figure 6 shows the active and reactive components of three phase load current which compared with standard three phase current set with standard phase difference.

### 4.2. Result from scope of magnitude calibration model

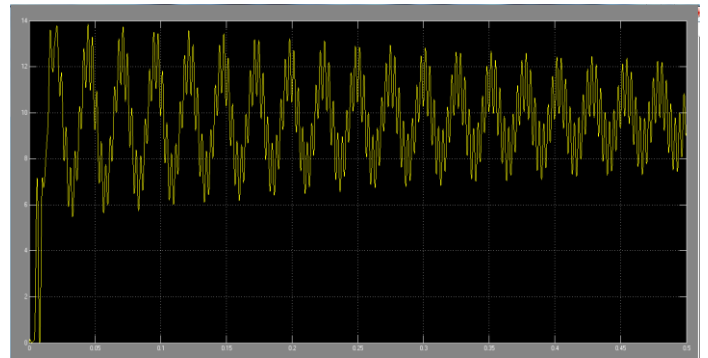


**Fig-7:** MATLAB simulink result for magnitude calibration result

### 4.3. Solar system current response



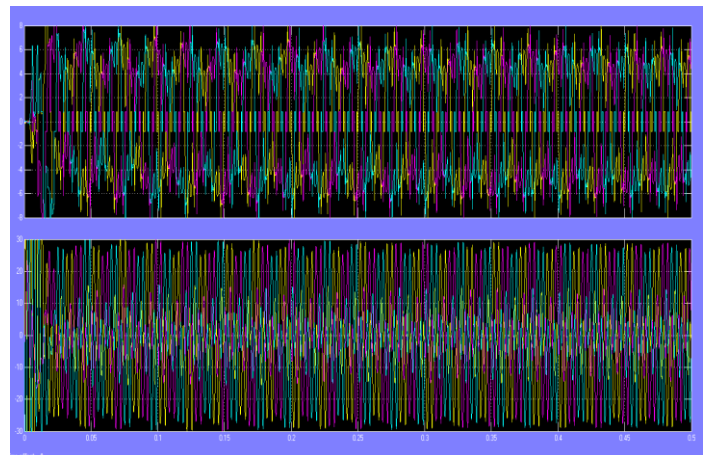
**Fig-8:** Solar subsystem response voltage in MATLAB simulation



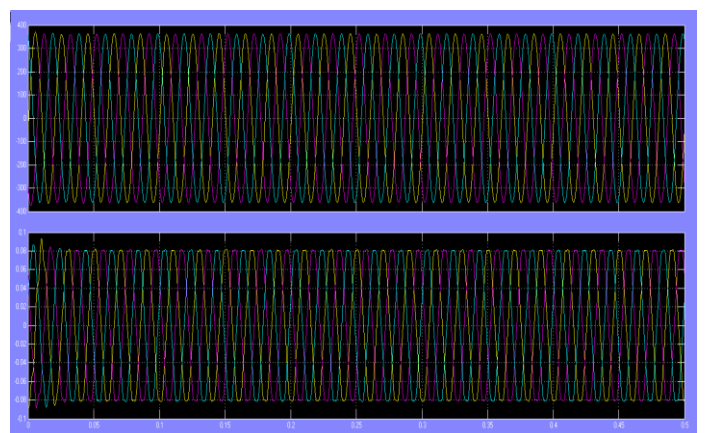
**Fig-9:** Solar system current output response

Figure 8 & 9 shows the output generated DC voltage and current for 25 degree and 800 irradiation. In which 20 volt DC voltage generated by solar PV subsystem while 10A output current generated by system.

### 4.4. Multilevel inverter parameter



**Fig-10:** Output voltage and current from multilevel inverter with harmonics content



**Fig-11:** Output voltage and current response of LC filter without multilevel harmonics content



#### 4.5. Three phase induction motor drive parameter

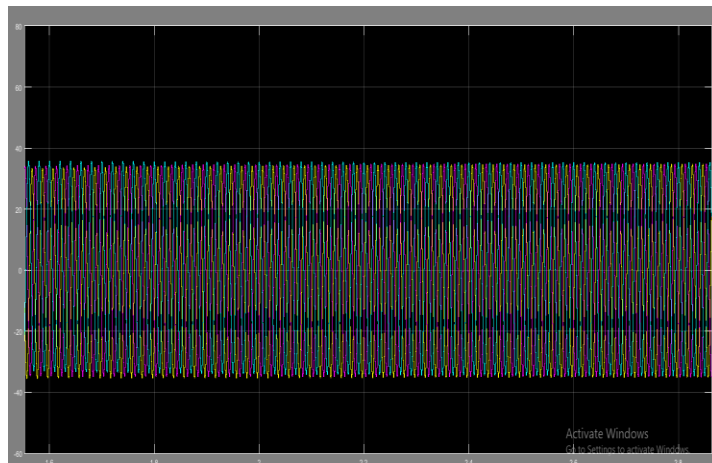


Fig-12: Three phase AC induction motor load current

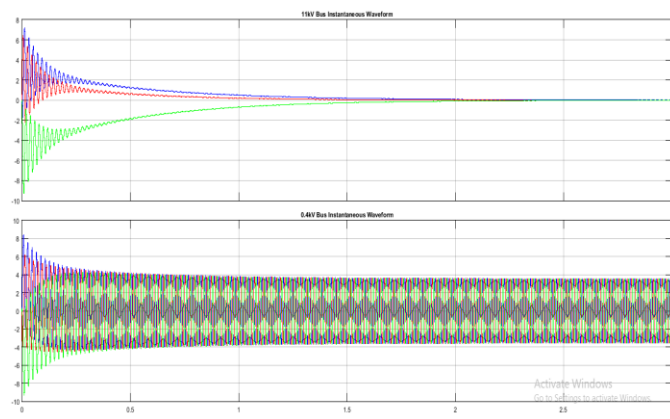


Fig-13: Three phase rotor current and stator current

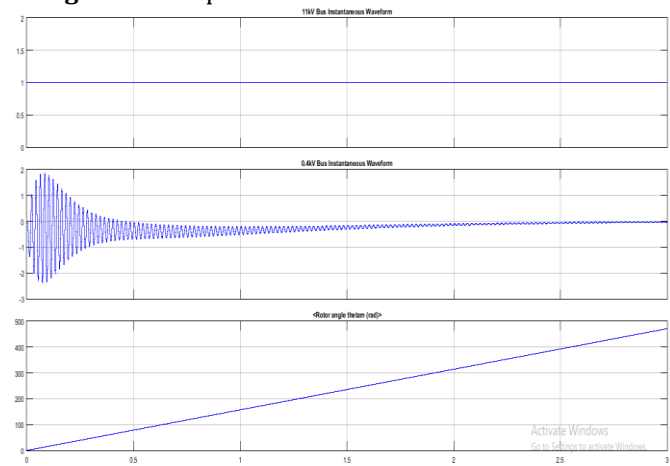


Fig-14: tor speed in pu, electromagnetic torque in pu, and rotor angle in pu

#### 5. CONCLUSION

A new converter topology for drives is presented in this methodology: a three-phase multilevel converter with separately regulated dc power supplies. The dc voltages are provided by medium-frequency dc-dc converters. The applications for the converter are especially high-power traction systems, where the voltage applied to the induction motor is bigger than 1 kV. The motor current is of a very high quality, compared to a classical three-phase converter. This allows keeping the switching frequency low by using phase-shifted pulsewidth modulation (PWM) carriers.

#### 6. FUTURE SCOPE

This project extends for speed controlling of synchronous motor. This project may be extend for controlling of DC series motor or DC shunt motor by controlling dc source voltage.

#### REFERENCES

- [1]. J. S. Lai and F. Z. Peng, "Multilevel converters – A new breed of power converters," *IEEE Trans. Ind. Applicat.*, vol. 32, pp. 1098–1107, May/June 1996.
- [2]. J. Rodriguez, J.-S. Lai, and F. Z. Peng, "Multilevel inverters: a survey of topologies, controls, and applications," *IEEE Trans. Ind. Electron.*, vol. 49, pp. 724-738, 2002.
- [3]. L. M. Tolbert, F. Z. Peng, and T. G. Habetler, "Multilevel converters for large electric drives," *IEEE Trans. Ind. Applicat.*, vol. 35, pp. 36-44, 1999.
- [4]. H. Stemmler. Power electronics in electric traction applications. *IEEE conference of Industrial Electronics, Control and Instrumentation, IECON'93*, 2:7 07 – 713, 1993.
- [5]. H. Fujita, S. Tominaga, and H. Akagi. Analysis and design of an advanced static VAR compensator using quad-series voltage-source inverters. *IEEE Industry Apps Meeting*, 3:2565–2572, 1995.
- [6]. Y. Yoshioka, S. Konishi, N. Eguchi, M. Yamamoto, K. Endo, K. Maruyama, and K. Hino. Self-commutated static flicker compensator for arc furnaces. In *IEEE Applied Power Electronics Conference*, volume 2, pages 891–897, 1996.
- [7]. L. Gyugyi, "Power electronics in electric utilities: static var compensators.," *Proc. IEEE*, vol. 76, pp. 3, 1987.
- [8]. Peter W. Hammond. A new approach to enhance power quality for medium voltage AC drives. *IEEE Trans. Industry Applications*, 33(1):202–208, January 1997.
- [9]. M. F. Escalante, J. C. Vannier, and A. Arzande "Flying Capacitor Multilevel Inverters and DTC Motor Drive Applications," *IEEE Transactions on Industry Electronics*, vol. 49, no. 4, Aug. 2002, pp. 809-815.
- [10]. L. M. Tolbert, F. Z. Peng, "Multilevel Converters as a Utility Interface for Renewable Energy Systems," in

Proceedings of 2000 IEEE Power Engineering Society Summer Meeting, pp. 1271-1274.

[11]. L. M. Tolbert, F. Z. Peng, T. G. Habetler, "A Multilevel Converter-Based Universal Power Conditioner," IEEE Transactions on Industry Applications, vol. 36, no. 2, Mar./Apr. 2000 pp.596-603.

[12]. L. M. Tolbert, F. Z. Peng, T. G. Habetler, "Multilevel Inverters for Electric Vehicle Applications," IEEE Workshop on Power Electronics in Transportation, Oct 22-23, 1998, Dearborn, Michigan, pp. 1424-1431.

[13]. In-Dong Kim, Eui-Cheol Nho, , Heung-Geun Kim, , and Jong Sun Ko. 'A Generalized Undeland Snubber for Flying Capacitor Multilevel Inverter and Converter".IEEE transactions on industrial electronics, vol. 51, no. 6, December 2004.

[14]. R. H. Baker and L. H. Bannister, "Electric Power Converter," U.S. Patent 3 867 643, Feb. 1975.

[15]. A. Nabae, I. Takahashi, and H. Akagi, "A New Neutral-point Clamped PWM inverter," IEEE Trans. Ind. Applicat., vol. IA-17, pp. 518-523, Sept./Oct. 1981.

[16]. F. Z. Peng and J. S. Lai, "Multilevel Cascade Voltage-source Inverter with Separate DC source," U.S. Patent 5 642 275, June 24, 1997.

[17]. N. S. Choi, J. G. Cho, and G. H. Cho, "A general circuit topology of multilevel inverter," in *Proc. IEEE PESC'91*, 1991, pp. 96-103.