

Thermal Analysis of Tube in Tube Liquid –Liquid Spiral Heat Exchanger

Kartik M. Vyas¹, Rajdip J. Gohil², Neel S. Patel³, Prof. Mitesh B. Lalwani⁴

^{1,2,3}Student, Dept. of Mechanical Engineering, Vadodara Institute of Engineering, Kotambi, India

⁴Assistant Professor, Dept. of Mechanical Engineering, Vadodara Institute of Engineering, Kotambi, India

Abstract - The heat exchangers are playing vital role in heat transfer applications in evaporator, boiler etc. A spiral tube heat exchanger has been invented to improve the thermal performance of heat exchanger at the same flow area, the spiral tube heat exchanger is compared with straight tube heat exchanger using heat transfer rate to pressure drop ratio. Nowadays with need of more efficient thermal systems with high rate of heat transfer at faster rate and with compact in size is the major requirement of new heat exchanger and to overcome such difficult in the objective of present work is pipe in pipe liquid-liquid spiral heat exchanger and results were compare with conventional straight tube heat exchanger.

Keywords: Heat exchanger, Spiral Tube in tube

1. INTRODUCTION

The heat exchanger is the best application of heat transfer and Heat exchangers are devices used to transfer heat between two or more fluid streams at different temperatures. A large number of production facilities in many industries use processes in which heat is transferred between different fluids. The basic principle of heat transfer is extremely simple, two fluids at different temperatures are placed in contact with a conductive barrier (the tube wall) and heat is transferred from the hotter fluid to the colder fluid until they reach the same temperature level. In industrial processes this is carried out in heat exchangers of various types and styles usually purpose built for the process and site conditions of the application.

G. E. KONDHALKAR & V. N. KAPATKAT [1] gives the performance analysis of spiral tube heat exchanger over the shell and tube type heat exchanger. They found that the cost saving using spiral tube heat exchanger is around 15 –20 % as compared to shell and tube type heat exchanger and to establish that improvement in overall heat transfer coefficient as compared to shell and tube type heat exchanger from 400 to 650W/m²K. The process at higher velocity was not suitable. P. M. DESHPANDE, S. DAWANDE [2] studied horizontal spiral coil tube (HSTC) for various forces (viscous, buoyancy and centrifugal force) acting on fluid element in coil; of which the centrifugal force is predominant and results in secondary

flow. This phenomenon also depends on the physical properties of fluid at a given temperature. They also concluded that as the coil diameter reduces the curvature ratio increase that increases the pressure drop. P. Naphon [3] proposed that the heat exchanger consists of a shell and helically coiled tube unit with two different coil diameters. Cold and hot water are used as working fluids in shell side and tube side. The cold and hot water mass flow rates ranging between 0.10 and 0.22 kg/s, and between 0.02 and 0.12 kg/s. R. K. PATIL, & B.W. SHENDE et. Al. [4] proposed that heat transfer rate of helical coil heat exchanger is better to compare other types of heat exchanger. In the helical coil heat exchanger space is limited so not enough straight pipes should be laid. The helical tube heat exchangers consist of helical coil fabricated out metal pipe that is fitted in the annular portion of two concentric cylinders.

2. Experimental Set up

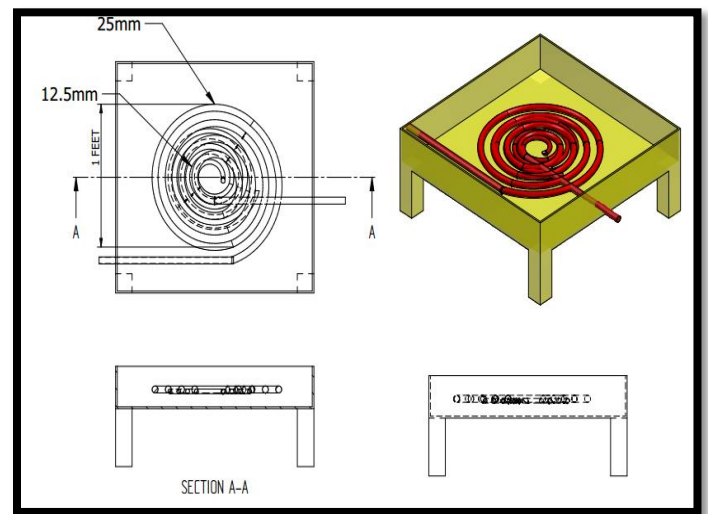

Fig 1 CAD Model



Fig 2 Spiral Tube in Tube



Fig 3 Submersible Pump



Fig 4 Fabrication of Set up



Fig 5 Final Experimental Model



2.1 Construction Model

In the present work two copper pipes one of ½” diameter which is readily available and other one which is of 1” diameter is fabricated from copper sheet of 20 gauge, both coils are shaped in spiral form to fabricate tube in tube spiral heat exchanger and photos of fabrications are presented in this chapter.

In this work in the first phase the spiral shape heat exchanger type two coil will be manufactured through which hot and cold water will flow. The temperature at various can be measured using K type thermocouples; by varying the flow rate its effect on the performance heat exchanger can be evaluated.

3. Results and Discussion

	Parallel Flow(°C)	Counter Flow (°C)
Cold water in	29.5	29.5
Cold water out	34	33.3
Hot water in	55	55
Hot water out	47.2	44.2

$$\epsilon = \frac{(T_{h1}-T_{h2})}{(T_{h1}-T_{c2})} \text{ (Parallel Flow)}$$

$$\epsilon = \frac{(T_{h1}-T_{h2})}{(T_{h1}-T_{c1})} \text{ (Counter Flow)}$$

Effectiveness

Parallel Flow	Counter Flow
33 %	40 %

In case of spiral tube in tube heat exchanger the heat exchanger is compact in size and more turbulence in the flow also effectiveness is better in case of counter flow heat exchanger.

4. Conclusion

The major conclusion of present work is that the spiral tube heat exchanger though difficult to manufacture but it is compact in size and use more turbulence in the flow so the better effectiveness can be obtain as in case of parallel flow it is 33.80% and in counter flow it is 40%

References:

1. G. E. Kondhalkar & V. N. Kapatkat, Performance Analysis of Spiral tube heat exchanger used in oil extraction system. International Journal of Modern Engineering Research, Vol.2, Issue.3, PP – 930 – 936, ISSN No.2249 – 6645, May – June 2012
2. P.M.Deshpande & Dr. S. Dawande, “Study Of Hydrodynamics Of Horizontal Spiral Coil Tube.” International Journal of Advanced Engineering Research and Studies, Vol. 1, Issue. 3, PP – 112 – 114, ISSN No. 2249 – 8974, Apr – June 2012.
3. Paisarn Naphon, Thermal performance and pressure drop of the helical-coil heat exchangers with and without helically crimped fins, International Communications in Heat and Mass Transfer Volume 34, Issue 3, March 2007, Pages 321-330
4. R. K. PATIL, B.W. SHENDE, P.K.GHOSH, “Designing Of Helical Coil Heat Exchanger.” Chemical Engineering, PP – 85 – 88, Dec. 1982.