

REVIEW PAPER ON MAGLEV WIND TURBINE

Aman Jain¹, Aditya Gupta², Dinakar Singh³, Kamal Sharma⁴

^{1,2,3,4} Student, Department of Mechanical Engineering, Krishna Institute of Engineering and Technology, Ghaziabad, Uttar Pradesh, India

Abstract - A vital factor being developed of human asset is the Energy. As regular energy sources are debilitating thoroughly, the improvement of endless and sustainable power source assets like wind, sunlight based is basic for human life. The wind control been used by individual for a more prominent day and age and today wind control is pulling in the advantages of energy division and their application is going into speedier improvement. The customary Wind turbine requires high structures to permit space for their enormous edges thus Maglev Turbines are a perfect arrangement. Maglev wind turbines have a few points of interest over ordinary wind turbines. For example, they're ready to utilize twists with beginning paces as low as 1.5 meters for each second (m/s). Likewise, they could work in winds surpassing 40 m/s. At introduce the biggest ordinary wind turbines on the planet create just five megawatts of energy. Be that as it may, one extensive maglev wind turbine could create one GW of clean power, enough to supply vitality to 750,000 homes.

Key Words: Energy, Sustainable Power Source, Wind, Maglev, Turbines, Maglev Wind Turbine

1. INTRODUCTION

Human have invented thousand of machines and appliances that use energy to make the everyday works less demanding, e.g. to warm our home, to get ourselves from place to place. A portion of these machines utilize electricity, while others like vehicles utilize the energy put away in gas. A great part of the energy supply originates from coal, oil, flammable gas or radioactive component. Truth be told, all these regular asset stores took a large number of years to shape. They are considered non inexhaustible which implies once they are expelled starting from the earliest stage, are not quickly supplanted inside the human timescale. The investigation of sustainable power source is the main way to diminish our reliance on non-renewable energy sources. Among those sustainable power source assets, wind energy is the main asset that will be worried in this paper. Wind energy was

first reaped hundreds of years prior, when early windmills were utilized to power millstones, pumps, and forges. Different outlines have been proposed to make a high productive wind turbine which ready to create most extreme electric power. They may either the plan of shape of the turbine sharp edges, the hub of pivot, and other helpful adjustment. As of late, a propel strategy, Magnetic Levitation (Maglev) is fused into turbine framework with a specific end goal to satisfy the requirements of those

vitality ventures. The Maglev wind turbine, which was first uncovered at the Wind Power Asia presentation in Beijing, is relied upon to take wind control innovation to the next level with magnetic levitation

1.1 Energy in a moving object

Any moving object has energy. This type of energy is called kinetic energy. For example, a car, a bicycle, or a ball, when moving, all have kinetic energy. The amount of energy of a moving object depends on two factors, its mass and its speed.

The same is true for moving air when wind strikes an object it exerts a force in an attempt to move it out of the way. Some of the wind energy is transferred to the object, in this case the windmill, causing it to move.

1.2 Energy resources

Since 10 years the interest for electricity is expanding at disturbing rate and the interest for control running in front of supply. The present day techniques are not adequate to keep pace with regularly expanding request. Energy emergency has compelled to think and build up the power age by sustainable sources (basically wind control). It is assessed that sustainable sources may contribute around 30%-half to energy utilization in the later piece of the 21st century. World Wind Energy Association gauges wind control limit is required to have a foreseen net development rate of over 21% every year.

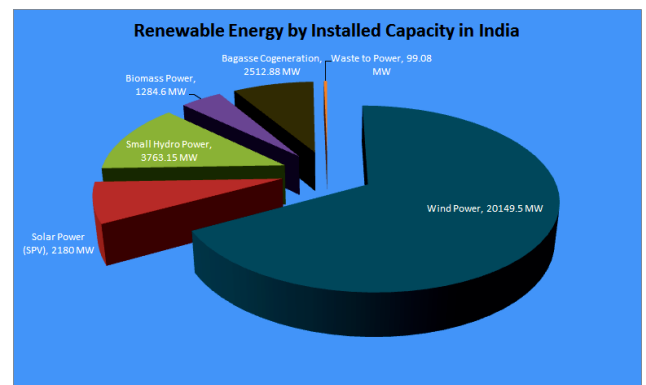

Fig-1: Renewable Energies by Installed Capacity in India

2. WIND ENERGY

Without a doubt, the task's capacity to work is exclusively subject to the energy of wind and its

accessibility. Wind is known to be another type of sun based vitality since it occurs because of uneven warming of the environment by the sun combined with the dynamic geography of the world's surface. With wind turbines, two classes of winds are pertinent to their applications, in particular neighborhood winds and planetary winds. The last one is the most predominant and it is typically a central point in choosing locales for extremely powerful wind turbines. These winds are generally found along shore lines, peaks, valleys and open fields. The previous is the sort you will discover in standard situations like the city or provincial regions, fundamentally where settlements are available. This kind of wind isn't helpful for power generation; it just has a considerable measure of worth when it goes with moving planetary winds.

3. WIND POWER

The wind power increases as a function of the cube of the velocity of the wind and this power is calculable with respect to the area in which the wind is present as well as the wind velocity. When wind is blowing the energy available is kinetic due to the motion of the wind so the power of the wind is related to the kinetic energy.

We know:

$$\text{Kinetic energy} = 0.5 mv^2$$

The volume of air passing in unit time through an area A , with speed V is AV and its mass is equal to the Volume V multiplied by its density ρ so

$$M = \rho AV$$

Substituting the value of M in equation 4.1 we get:

$$\text{Kinetic energy} = 0.5 (\rho AV)V^2 = 0.5 \rho AV^3$$

The power being generated can be calculated, however one should note that it is not possible to convert all power of the wind into power for generation. The power harnessed from the wind cannot exceed 59% of the overall power in wind.

4. MAGNETIC LEVITATION

Magnetic levitation is a method in which an object is suspended with no support other than magnetic fields. The magnetic force produced is used to counteract the effects of the gravitational force and lift up the object. There are many advantages for utilizing magnetic levitation that is to minimize friction, stress on shaft etc. Recently, this advance technology is applied into transportation system in which non contacting vehicle travel safely at very high speed while suspended, guided, and propelled above a guide way by magnetic fields. The concept of magnetically levitated vehicle stimulates the development of useful application in various fields such as the power generation.

5. MAGLEV WIND TURBINE

Unlike the conventional type, the vertically oriented blades of the wind turbine are suspended in air by using permanent magnet which produces magnetic force to lift up the blades. Since the turbine blades are suspended by magnetic force produce by the permanent magnet, there is no need of ball bearing to retain the blades. This allows the friction between the blades and ball bearing can be reduced significantly and thus, minimizes the energy loss. This also helps reduce maintenance costs and increases the lifespan of the generator. The Maglev wind turbine, which was first unveiled at the Wind Power Asia exhibition in Beijing, is expected to take wind power technology to the next level with magnetic levitation.

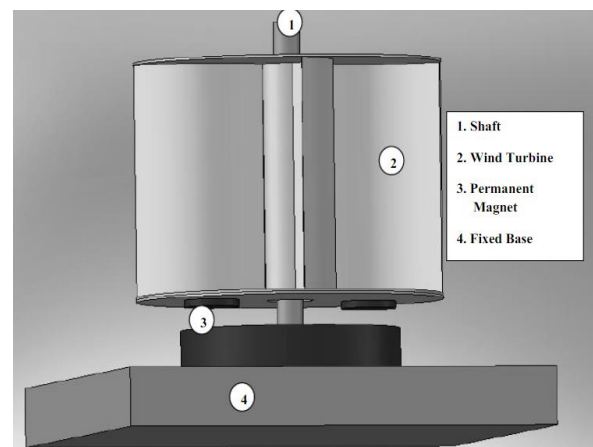

FIG-2: Basic model of maglev wind turbine



FIG-3: Fabricated model of maglev wind turbine

5.1. Components used to construct



FIG-4: Plywood sheets cut into circle of 30 cm diameter



FIG-7: Aluminium blades of 30 cm height

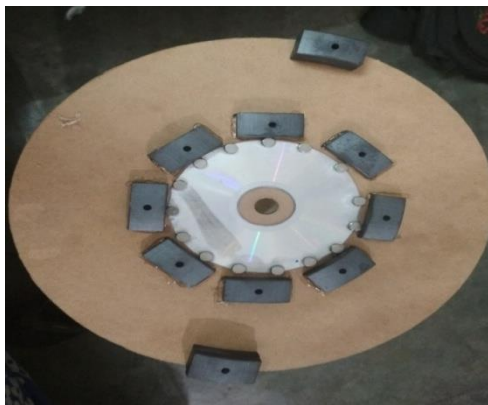

FIG-5: Arc bar magnets of length 40 mm and thickness 20 mm and Ni-Cd magnets of 5 mm diameter

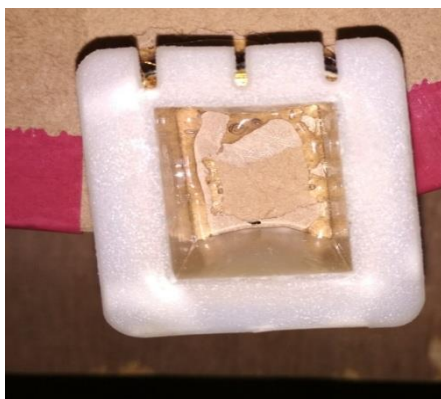

Fig -6: Copper coil of 1000 turns

6. EXPERIMENTAL OBSERVATIONS

S.NO.	N (rpm)	Striking Velocity (m/s)	V (Volts)
1	140	2.566	0.170
2	160	2.932	0.215
4	214	4.105	0.400
5	230	4.214	0.530
6	264	4.83	0.640
7	300	5.497	0.930
8	340	6.230	1.100

7. CONCLUSION

Over all, the magnetically levitated vertical axis wind turbine was a success. The rotors that were designed harnessed enough air to rotate the blades at low and high wind speeds while keeping the centre of mass closer to the base yielding stability. The wind turbine levitated properly using permanent magnets which allowed for a smooth rotation with negligible friction. At moderate wind speeds the power output of the generator satisfied the specifications needed to supply the LED load.

The home for the attractively suspended vertical hub wind turbine would be in local locations. Here it can be mounted to a rooftop and be extremely proficient and pragmatic. A mortgage holder would have the capacity to remove free clean vitality in this way encountering a lessening in their utility cost and furthermore add to the "Environmentally friendly power Energy" mindfulness that is progressively picking up fame.

8. RECENT DEVELOPMENTS

Prerna Energy Corporation Private Limited in India is investigating chances to set up MAGLEV. Current research techniques used now a day are producing more grounded, lighter and more proficient edges for the turbines. Indian Renewable Energy Development Agency (IREDA) and the wind business are cooperating to achieve the changes through different innovative work programs.

REFERENCES

1. Dinesh N Nagarkar and Dr. Z. J. Khan, "*Wind Power Plant Using Magnetic Levitation Wind Turbine*", International Journal of Engineering and Innovative Technology (IJEIT) Volume 3, Issue1, July 2013
2. Piyush Gulve, Dr. S.B.Barve, "Design And Construction Of Vertical Axis Wind Turbine", International Journal of Mechanical Engineering and Technology (IJMET), Volume 5, Issue 10, October (2014), pp. 148-155.
3. Vishal D Dhareppgoal and Maheshwari M Konagutti, "*REGENEDYNE Maglev Wind Power Generation*", SARC-IRAJ International Conference, 16th June 2013, Pune, India.