

# SYNCRETIC USE OF SMART METER FOR POWER QUALITY MONITORING AND ENERGY MANAGEMENT IN EMERGING NETWORKS

Mrs. Anusha M N<sup>1</sup>, Mrs. Kokila K S<sup>2</sup>, Niveditha G J<sup>3</sup>, Poornima K S<sup>4</sup>, Ranjana B R<sup>5</sup>, Rashmi A J<sup>6</sup>

<sup>1,2</sup> Asst. Professor, Dept. of ECE, BGS Institute of Technology, Mandya

<sup>3,4,5,6</sup> Student, Dept. of ECE, BGS Institute of Technology, Mandya

\*\*\*

**Abstract** - The Existing power quality monitoring system, mainly to get the data through special acquisition equipment of power quality, it is not for real time monitoring of each user power consumption. It is difficult job for the electricity distributors to manually take meter readings and calculate bill. Domestic energy consumer is unaware of his power usage and also difficult to energy management. Hence considering all these factors it is possible to design a smart meter that supports power quality monitoring, energy management and automatic billing. The goal of providing such data is to optimized and reduces the power consumption. The energy Meter proposed here deals with the measurement of current, voltage and consumption of power. GSM is used to send a message to a domestic user with information on billing. This smart meter is user friendly and it makes consumers aware about the amount of energy they utilize and help to save the resources. The automation of billing system reduce the human resources involvement, hence is more accurate.

**Key Words:** Smart meter, GSM, Power quality monitoring, Energy management, Automatic billing.

## 1. INTRODUCTION

Smart billing is an important part of energy management. For every month the person from distribution side come and collect the meter reading and produce the bill to the consumer. The problem with existing system is that it requires human power, time consuming and may causes error. So there comes the scope of a "SMART METER" which will provide bill to consumer both as an SMS and it also monitor the power quality. The proposed energy meter utilizes a GSM module to transfer energy consumed to the authority side. Similarly distribution side also uses these GSM service to send back the bill. Electricity thefting is also common issue now that's why energy management is introduced. The main disadvantage of mechanical meter was it was less reliable, less accurate and non-tamper proof. Even the present day electronic energy meters used by electricity board are not completely tamper proof. The proposed smart meter also have the feature of detecting voltage and current variation in the distribution system, made by checking the status of supply at distribution transformer and that at consumer. With line to measure current flowing through the load and a potentiometer is connected to the line to measure threshold voltage of load. Then it multiplies them to get power in that instant. Then it processes these values of power to calculate the total power consumed by load and calculates the power quality. Automated billing of smart

meter is made possible by connecting a GSM modem to the energy meter. As the authorities request for the units of energy consumption the same is send to them through GSM service from the smart meter. Once the value reaches the board they prepare a bill and send this to the registered mobile number of the consumer.

### 1.1 Smart Meter

Energy meter or watt-hour meter is an electrical instrument that measures the amount of electrical energy used by the consumers. Utilities is one of the electrical departments, which install these instruments at every place like homes, industries, organizations, commercial buildings to charge for the electricity consumption by loads such as lights, fans, refrigerators and other home appliances.

Energy meter measures the rapid voltage and currents, calculate their product and give instantaneous power. This power is integrated over a time interval, which gives the energy utilized over that time period.

### 1.2 Existing System

In the existing system, electricity meter reading for power usage and billing is done by labors from home to home. Their requires more labors and long working time to complete area data collection and billing. The Labors billing leads to reading error as sometime the electric meter is placed inside the home where it is not able take the readings. Labor billing job is sometime also limited and th process is slowed down by bad environmental condition. In olden days, electricity is available only to a specific region. The technology updates which encourages to meet the common people requirements in all over the world. The history of electricity meter is well connected involving researchers from past. The general usage of electricity in the early 1870's is only confined to telegraphs and arc lamps. With the invention of the electric bulb by Thomas Elva Edison, in the year 1879.

### 1.3 Proposed Method

The smart meter system consists of an external circuit for collect meter reading and communicates through the GSM, along with an external hardware circuit. Meter readings are passed through the GSM module connected to the smart meter. The external circuit also provides an option to cut the power supply to consumer when the variation in the power quality, by the help of relay control unit connected

through the smart meter section. It provides the useful functionality of automatic switching the power ON/OFF to the user. It consists of a protective relay, threshold voltage breaker. Another feature is theft detection, which helps to detect unauthorized power consumption from home or commercial buildings. This theft detection was done by the help of buffer; this buffer is a part of the external hardware circuit. By operating this buffer the relay control unit starts working. Any theft was detected with the help of GSM user get notifications also it provides an option of cut the power to unauthorized consumer. Smart Meters are advanced sophisticated meters that collect the energy utilization data more accurate than the traditional electric meters and communicate that information back to the utility providers for monitoring, controlling and billing purposes.

## 2. BLOCK DIAGRAM

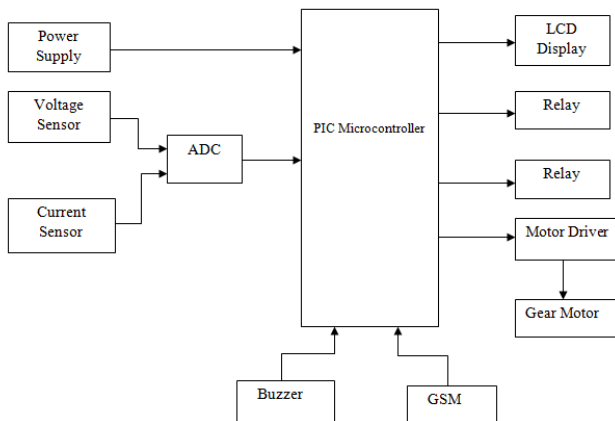

Fig -1:Block diagram

GSM communications network is used to transfer the electricity consumed data to the distributor and to the customer when demanded. Antenna, attached on or near meter box, can be used for improvement of signal strength in GSM communication. Smart metering communication is centralized meter reading, power quality monitoring and energy management, so meter readers don't need to visit each customer for data collection. However, for testing and maintenance meters may need to observe occasionally. The main duty of Smart Meter is to measure the meter reading and sends it to costumer and monitor the quality of power. The voltage and current sensors measure the RMS values of voltage and current and feed them to microcontroller, where calculations for active and reactive power are performed. In Smart Energy Meter we used voltage sensors and current sensor to measure voltage and current.

A major feature of Smart Energy Meter is that distributor can cut off and reconnect the connection of energy of any user with the help of SMS without sending the person to perform the task manually. It can be utilized in case when the utility company needs to disconnect a consumer due to non-payment of bills or some other reasons. Another major feature of Smart energy meter is that it gives buzzer when

the consumer load is exceeding the upper limit for which he got the distribution. In case consumer does not reduce his load meter automatically cut off the consumer connection.

### 2.1 PIC Microcontroller

PIC microcontrollers are a family of specialized microcontroller chips produced by Microchip Technology. The PIC stands for "peripheral interface controller". Pic microcontroller which is programmed by embedded C. This generates the output so that the LED lights is switched OFF/ON. The PIC microcontroller programming is performed through 'MP-Lab' software. It even reacts accordingly as per programed, to the situations like message sending during threshold value etc.

### 2.2 GSM MODULE (SIM900)

GSM stands for Global System for Mobile communication. It is widely used mobile communication modem system in the world. GSM is a wireless communication, open and digital cellular technology which is used for transmitting mobile voice and data services operates at the 850MHZ, 900MHZ, 1800MHZ, 1900MHZ frequency bands. It has ability to carry 64kbps to 120Mbps of data rates.

In our system GSM is used to send the notification of threshold voltage reaching to consumer and for sending message of total consumption of unit with cost to the service consumer.

### 2.3 DRIVER CIRCUIT

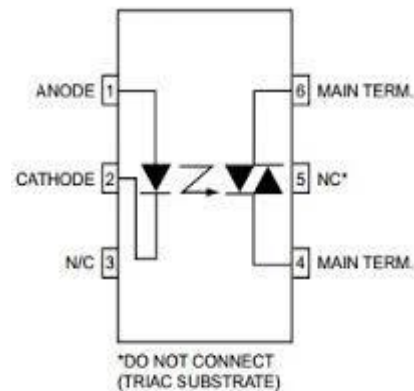

Figure 4: Driver Circuit

Motor Driver is a small current amplifier ;the function of motor driver is to take a low current control signal and then convert it into a higher- current signal that can drive a motor. Which is used to convert the current of home appliances like fan, Refrigerator etc.

### 2.4 Voltage sensor

It is a device that coverts voltage measured between two points of an electrical circuit into a physical signal proportional to the voltage. It facilitate the monitoring of

supply voltage levels. They identify under voltage or over voltage concerns and help critical motor and electronics. It takes the voltage value from the mains and compares with the threshold value.

## 2.5 Embedded C

Embedded C Programming Language, which is most largely used in the development of Embedded Systems and circuits, it is a part or an extension of C Program Language. The Embedded C Programming Language uses the same syntax and semantics of the C Programming Language like main function, declaration of data types, defining variables, loops, functions, statements, etc. The Embedded C which is an extension of standard C Programming Language. This include I/O Hardware Addressing, registers, arithmetic operations, accessing address spaces, logical operations etc.

## 3. CONCLUSION

In the proposed Smart Meter using GSM would go a long way in making people aware of the amount of energy they spend and help to conserve the conventional resources. The automation of billing system eliminates human involvement hence more accurate and reliable. The implementation of time of monthly billing can control the usage of electricity on consumer side to avoid wastage of power which helps in reduction of energy generation costs. The introduced Prepaid Billing System minimizes the Electricity theft in a cost effective manner. Automation of meter reading also gives the information of total load used in a house on request at any time as well as to make consumers to keep track of energy usage. It sends a SMS alert to energy provider company whether a person using more than specify limit of load.

## REFERENCES

1. W. F. Durand, "Why the engineer?" *Trans. Amer. Inst. Elect. Eng.*, vol. 55, no. 12, pp. 1301–1303, Dec. 1936.
2. R. Hierzinger et al., *European Smart Metering Landscape Report 2012—Update May 2013*.
3. IEC Electromagnetic Compatibility (EMC)—Part 4-30: Testing and Measurement Techniques—Power Quality Measurement Methods, IEC Standard 61000-4-30, 2015. 492 *IEEE TRANSACTIONS ON SMART GRID*, VOL. 8, NO. 1, JANUARY 2017
4. EN Voltage Characteristics of Electricity Supplied by Public Electricity Networks, EN Standard 50160, 2010.
5. P. Caramia, G. Carpinelli, and P. Verde, *Power Quality Indices in Liberalized Markets*. Chichester, U.K.: Wiley, 2009.
6. C. Muscas, "Power quality monitoring in modern electric distribution systems," *IEEE Instrum. Meas. Mag.*, vol. 13, no. 5, pp. 19–27, Oct. 2010.
7. S. Ali, K. Wu, K. Weston, and D. Marinakis, "A machine learning approach to meter placement for power quality estimation in smart grid," *IEEE Trans. Smart Grid*, vol. 7, no. 3, pp. 1552–1561, May 2016.