

DESIGN AND FABRICATION OF COST EFFECTIVE ELECTRIC GO KART

Prof. Ambepasad Kushwaha¹ & Prof. Avinash Chavan²

Tapeshwar A. Das³, Shubham S. Kenjale⁴, Jay A. Patel⁵, Pradeep R. Prajapati⁶

^{1,2} Professor, Department of Mechanical Engineering, University of Mumbai S.J.C.E.M., Vevoor, Palghar (E), Palghar, Maharashtra 401404.

^{3,4,5,6} Students, Department of Mechanical Engineering, University of Mumbai S.J.C.E.M., Vevoor, Palghar (E), Palghar, Maharashtra 401404.

1. Abstract: Each and every day the prices of petrol and diesel keeps on fluctuating. They increase with higher rate but rarely falls down. This is tremendously depleting the fuel reserves. So basically it is important to design such vehicle that could work on electric energy rather than fuels, as electric energy is available in larger amount compared to fuels.

This paper aims to design and development of working model of cost effective electric go-kart. Main objective behind designing and fabricating the electric go -kart is to make it available in cheap price, making it simple in working for even nonprofessional drivers, increasing is strength so that it can sustain more weight and providing it with all the best available facilities in lower cost . The paper mainly focuses on the material selection and designing of cheaper electric system compared to other electric go-karts manufactured, calculations required for designing the kart, basic required analysis.

Keywords: Calculations, analysis, Material selection, Electrical connection. Motor, Battery.

2. INTRODUCTION:

Go-kart is a four wheeled, mini racing car used mainly in United States. It was manufactured in late 1950's by Art Ingles. Kart racing is generally accepted as the most economic form of motor sport available. A go-kart is basically a type of mini car without suspension system and even without differential due to least clearance between karts base and the track.

Go-kart racing is basically preferred for introducing the drivers to motor sports. They resemble to the formula one cars but it is not as fast as F1 and also costs very less. This helps racing enthusiasts in adopting the racing environment as, go-karts are even used as training vehicles before entering into professional motor sports world where F1 cars are the only option.

3. CALCULATIONS:

3.1 Speed Calculation:

$$\text{Gear ratio} = \frac{Z_g}{Z_p} = \frac{42}{11} = 3.818: 1$$

$$\text{Speed} = \text{Tyre Radius} * \text{Rotational}$$

$$\begin{aligned} & \text{Velocity} \\ & \text{168 * Gear ratio} \\ & = 8 * 3000 / 168 * 3.818 \\ & = 37.416 \text{ mph} \end{aligned}$$

Speed in kmph will be:

$$\begin{aligned} \text{Kmph} &= \text{mph} * 1.609344 \\ &= 19.03 * 1.609344 \\ &= 60.21 \text{ kmph} \end{aligned}$$

3.2 Braking System:

a) Gross weight of vehicle: (W) = 170 * 9.81 = 1667.7 N

b) Brake Line Pressure:

$$\begin{aligned} \text{Pedal ratio} &: 4:1 \\ \text{Normal force on pedal} &: 2000\text{N} \\ \text{Area of master cylinder} &: 334.06\text{mm}^2 \\ \text{Brake line Pressure} &= 23.94 \text{ N/mm}^2 \end{aligned}$$

c) Clamping Force:

$$\begin{aligned} \text{CF} &= \text{B Pressure} * (\text{Area of caliper} \\ & \text{Piston} * 2) \\ \text{CF} &= 23.94 * \left(\frac{\pi}{4}\right) * 27^2 * 2 \\ \text{CF} &= 27413.94 \text{ N} \end{aligned}$$

d) Rotating Force:

$$\begin{aligned} \text{RF} &= \text{CF} * \text{no of caliper piston} * \\ & \text{Coeff. Friction of brake pads} \\ &= 27413.94 * 2 * 0.4 \\ &= 21931.152 \text{ N} \end{aligned}$$

e) Braking Torque:

$$\begin{aligned} &= \text{RF} * \text{effective disc radius} \\ &= 21931.152 * 0.0875 \\ &= 1918.97 \text{ Nm} \end{aligned}$$

f) Braking Force:

$$\begin{aligned} \text{BF} &= \text{braking torque} / \text{tyre radius} \\ &= (1918.97 / 0.41) * 0.8 \end{aligned}$$

$$= 3744.3317 \text{ N}$$

g) Deceleration:

$$\begin{aligned} BF &= -ma \\ \text{i.e } a &= -BF/m \\ &= -(3744.3317 / 170) \\ &= -22.025 \text{ m/s}^2 \end{aligned}$$

h) Stopping Distance:

$$\begin{aligned} v^2 - u^2 &= 2 * a * ds \\ \text{Where,} \\ u &= 60.21 \text{ km/hr} = 16.725 \text{ m/s} \\ v &= 0 \\ ds &= v^2 - u^2 / 2a \end{aligned}$$

$$\frac{ds = 0^2 - 16.725^2}{2 * (-22.025)}$$

$$ds = 6.3501 \text{ m}$$

3.3 Steering System Calculation:

$$\begin{aligned} R &= \sqrt{(A^2 + B^2)} + B \\ &= \sqrt{(1255.2^2 + 1102.8^2)} + 1102.8 \\ &= 2.7\text{m (turning radius)} \end{aligned}$$

a) Outer Angle:

$$\begin{aligned} \tan X &= \frac{L}{R-d/2} = \frac{1255.2}{2773.636-1102.3/2} \\ &= 29.459^\circ \end{aligned}$$

b) Inner Angle:

$$\begin{aligned} \tan Y &= \frac{L}{R+d/2} = \frac{1255.2}{2773.636 + 1102.8/2} \\ &= 20.6815^\circ \end{aligned}$$

3.4 Go kart Axle Rotational Speed :

a) X = 3000 RPM motor * 11 teeth drive / 42 tooth sprocket
Thus,

$$X = \frac{3000 * 11}{42} = 785.714 \text{ rpm}$$

$$P \geq 2.8 \times \sqrt{[Mt]}$$

$$\frac{11 \times 2 \times [\sigma_{br}]}{[\sigma_{br}] = 1.81 \text{ Kg/mm}^2}$$

$$\begin{aligned} [Mt] &= Mt * K_s = 3.18 * 1.25 \\ &= 3.975 \text{ Nm} \end{aligned}$$

$$P \geq \frac{2.8 \times \sqrt{3.975 * 10^3}}{11 \times 2 \times 18.1}$$

$$P \geq 6.028 \text{ mm}$$

b) Drive Selection Calculation:

$$D1 = \frac{P}{\sin(\frac{180}{Z1})} = \frac{6.02}{\sin(\frac{180}{11})} = 21.396 \text{ mm}$$

$$D2 = \frac{P}{\sin(\frac{180}{Z2})} = \frac{6.028}{\sin(\frac{180}{42})} = 80.6639 \text{ mm}$$

c) Length of chain

$$lp = 2ap + \frac{Z1+Z2}{2} + \left(\frac{Z2-Z1}{2\pi} \right)^2 / ap$$

$$lp = 2(40) + \frac{53}{2} + \left(\frac{42-11}{2\pi} \right)^2 / 40$$

$$lp = 107.1085 \text{ mm}$$

$$l = 66.8703 * 6.028 = 645.65 \text{ mm}$$

d) Final Center distance

$$a = \frac{e + \sqrt{e^2 - 8m}}{4} \times p$$

$$e = lp - \left(\frac{Z1+Z2}{2} \right)$$

$$e = 107.1085 - \left(\frac{42+11}{2} \right)$$

$$e = 80.6085 \text{ mm}$$

$$a = \frac{80.6085 + \sqrt{80.6085^2 - 8 * 2}}{4} \times 6.028$$

$$a = 242.8043 \text{ mm}$$

3.5 Tyre Reactions:

Total weight = 170kg

a) Reaction at Rear wheel

= 55% of total weight

$$= (55 / 100) * 1700$$

$$= 935 \text{ N}$$

b) Reaction at Front wheel

= 45% of total weight

$$= (45 / 100) * 1700$$

$$= 765 \text{ N}$$

c) Force required to cause both tyre to skid

$$F_t = \mu(935 + 935)$$

considering, $\mu = 2$

Thus,

$$F_t = 2(1870)$$

$$F_t = 3740 \text{ N}$$

3.6 Battery Selection:

a) Charging time of battery

= Battery Amph / charging current
 = Ah / A
 Charging current should be 10% of the Ah rating of battery
 Therefore, Ah = 35Ah
 Charging current for 35 Ah battery
 = $35 * 10/100$
 = 3.5 A
 Charging time of battery
 = $35/3.5 = 10$ hrs. (Ideal case)

b) Practical case:

40% of losses occurs,
 $35 * 40/100 = 14$
 $35 + 14 = 49$ Ah
 Charging time of battery = $49/3.5 = 14$ hrs

c) Discharge time =

Battery Ah * Battery volt

Applied Volt

$$= \frac{35 * 12}{1000}$$

= 0.42 hrs. = 25.2 min

Considering loss (max)

$$= 0.42 * 40/100$$

$$= 0.168 \text{ hrs.} = 10.08 \text{ min}$$

4. ANALYSIS/RESULTS:

Mesh of chassis

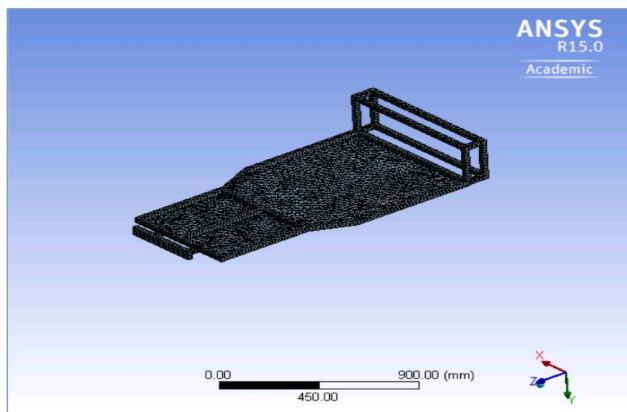

Object name	Mesh
State	Solved
Physics Preferences	Mechanical
Relevance	100
Relevance center	Fine
Element size	Default
Nodes	30235
Elements	14738
Mesh matric	None

4.1 Total deformation (Rear impact)

For deformation first load of 700N(Compressive) is applied on rear end and front end is fixed. Fig below shows the result:

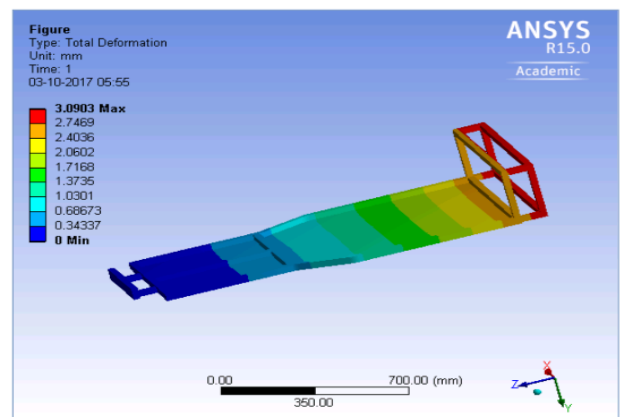

4.2 Total deformation (Front impact)

For deformation first load of 700N (Compressive) is applied on front end and rear end is fixed. Fig below shows the result:

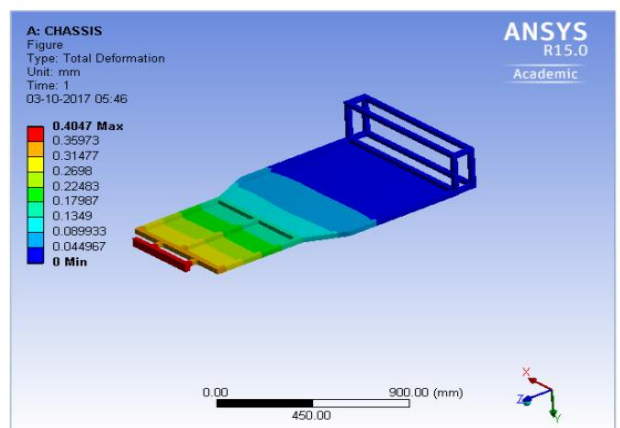

4.3 Equivalent stress (Rear impact)

For Equivalent stress first load of 700N (Compressive) is applied on rear end and front end is fixed. Fig below shows the result

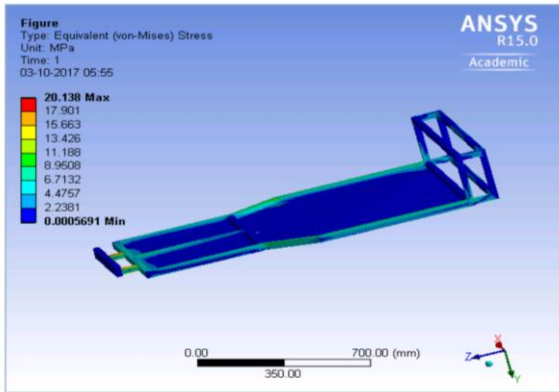

4.4 Equivalent stress (Front impact)

For Equivalent stress first load of 700N (Compressive) is applied on front end and rear end is fixed. Fig below shows the result

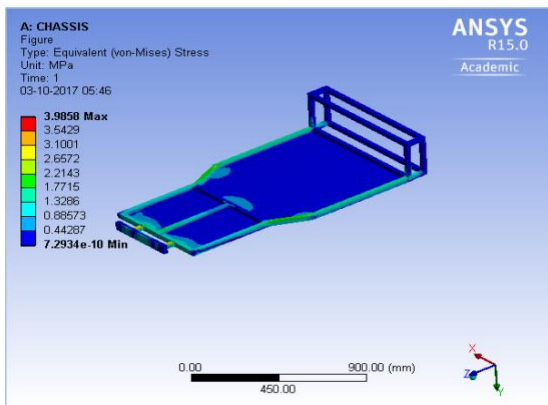

4.5 Total deformation of shaft

For deformation first load of 935N (Compressive) is applied on the shaft where one end is fixed.

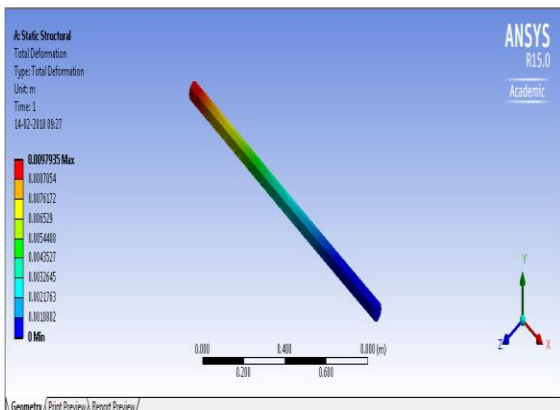

4.6 Torsional deformation of shaft

Moment of 935Nm(Compressive) is applied on the middle of the shaft and both the ends are fixed. Fig below shows the result for twisting moment

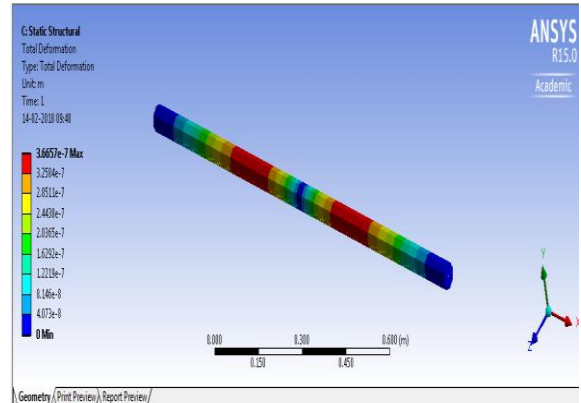

5. ELECTRICAL CONNECTION:



Power Connector § - Required Connection	+ Positive (Red) To Battery - Negative (Black) To Battery
Motor Connector § - Required Connection	+ Positive (Blue) To Motor - Negative (White) To Motor
Throttle Connector § - Required Connection	+ Positive (Red) To Throttle - Negative (Black) -OR- Derailleur § - Signal (Green)
Brake Lever Connector	+ Positive (Yellow) To Brake Lever - Negative (Black)
Half Speed Connector	Black Half Speed Connector Black Half Speed Connector

The main processing unit of the electrical system is ESC (Electronic Speed Controller). It itself consists of different port right from brake light up to accelerator. Battery is connected to battery port and throttle pedal is connected to derailleur in ESC unit. The battery need to be connected in series for getting complete power output. i.e. for 36V we connected 3*12v batteries in series. For power output short the power switch. And only on pressing throttle pedal, the current is passed to motor through the battery pack as throttle is the input which activates the MOSFET transistor and the system starts.

6. ACTUAL MODEL:



The above figure indicates the complete go-kart model after fabrication.

7. ACKNOWLEDGEMENT

We would like to thank our project guide and co-guide Mr. Ambepasad kushwaha & Mr. Avinash Chavan for helping us understanding details of our project and the head of mechanical department for allowing us to work in college machine shop and workshop. Lastly, we would thank the workshop staff and lab assistant Mr. Milind Thakur for guiding us through analysis and fabrication work

8. CONCLUSION

Manufacturing of electric go kart is done successfully, according to planned schedule. According to calculations, it is able to sustain weight and speed achieved around 40-45 kmph. It was successfully built in less than Rs.35,000 as expected, without compromising in its strength or other components quality.

9. REFERENCES

1. Asfan Mohiuddin, Mohd Sayeed, Md Nawaz "Steering System of Electric Go-Kart" International Journal for Research in Applied Science & Engineering Technology (IJRASET) Volume 5 Issue I, January 2017, IC Value: 45.98 ISSN: 2321-9653,Page 453-456.
- 2.Mohd Anwar, R.suman, Mohammed Salman, Vainateya, "Transmission System of Electric Go-Kart" International Journal Research in Applied Science & Engineering Technology (IJRASET), Volume 5,Issue I, January 2017, IC Value:45.98, ISSN: 2321-9653, Pages 445-452.JVHH
- 3.Govardhana Reddy, Md. Hameed, "design report of a go kart vehicle", International Journal of Engineering Applied Sciences and Technology, 2016,Vol. 1, Issue 9, ISSN No. 2455-2143 , Pages 95-102, Published Online July – August 2016.

4.Sathish Kumar Vignesh, "design and analysis of an electric kart", IJRET: International Journal of Research in Engineering and Technology, Volume: 04 Issue: 04 | Apr-2015, Page 9-17.

5.Dr.D.Ravikanth,Dr.K.Rajagopal,Dr.V.S.S. Murty, A. Harikrishna, "design of a go kart vehicle", International Journal of Science, Engineering and Technology Research (IJSETR) Volume 6, Issue 3, March 2017, ISSN: 2278 -7798 ,Page 448-456.