

# BRAIN CONTROLLED HOME AUTOMATION SYSTEM

Vidya G <sup>1</sup>, Vipitha E P<sup>2</sup>, Hridya S G<sup>3</sup>

<sup>1,2,3</sup> Student, Dept. of Electrical and Electronics Engineering, Mar Athanasius College of Engineering, Kothamangalam, Kerala India

\*\*\*

**Abstract** - Brain Computer Interface (BCI) is the direct connection between the computers and human brain. The BCI reads the waves produced from the brain at different locations in the human head, translates these signals into actions and commands, that can control the computers. We propose to integrate this technology with home automation. This interface system is especially useful for severely disabled or locked-in individual with no reliable muscular control over their body parts to interact with surrounded peripherals. The system involves two parts: an EEG sensor circuit and a Arduino microcontroller board. The brain waves are captured using electrodes. These signals are filtered and amplified to remove noise. These analog signal is converted to digital. The digital signals are decoded and are used to switch on a device.

**Key Words:** Brain computer interface, Automation, EEG, Arduino, Brainwaves

## 1. INTRODUCTION

Amazingly, nothing in the world can be compared with the human brain. Our Human Brain is highly complex and is made up of about 100 billion neurons. There are many types of neurons in our brain such as motor neurons, sensory neurons. These neurons get fired up while generating a response for a particular stimulus and generate an electrical signal. These electrical signals are not fully transferred from one neuron to another, but some part of it escapes and reaches the scalp. These signals are captured by the electrodes and used to control the device.

Home Automation is an area where BCI can be used and our entire house can be controlled simply by our brain. BCI is a direct communication pathway between an enhanced or wired brain and an external device. Brain computer interface can be classified into three main groups-invasive, semi-invasive and non-invasive. In invasive BCI systems, the EEG sensing device are directly placed on human brain through critical surgery. In semi-invasive BCI system, the EEG sensing device is placed on our skull, directly on top of human brain. In non-invasive BCI system, the EEG sensing device are placed outside our brain and is considered by far the most practical safest BCI system.

We have proposed a home automation system using BCI in this paper. Using this technology the life of people would be further simplified, physical efforts would be considerably reduced and it would also prove as a boon for physically disabled people.

## 2. HARDWARE DESIGN

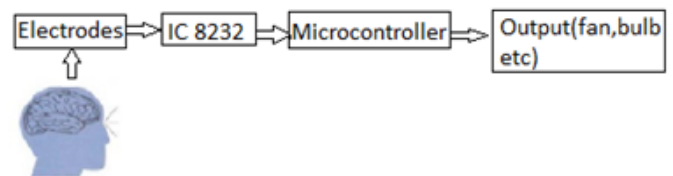

Fig -1: System Block diagram

It has basically an EEG sensor circuit and a microcontroller. EEG signal is acquired using electrodes. Our system uses 3 electrode scheme. The electrodes are placed in 3 forehead position. The EEG signal is filtered and amplified using amplifiers. The filtered and amplified signal is fed to a microcontroller (Nano board). The microcontroller converts the analog signal to digital signal. The components used in our hardware are:

### A. Electrodes

We will be using dry non-invasive AgCl disposable clinical electrode. We are using three electrode scheme. These three electrodes are placed in three particular positions in our forehead where we will obtain the electrical signals associated with our eyes.

### B. IC AD8232

The AD8232 is an integrated signal conditioning block for ECG and other bio potential measurement applications. It is designed to extract, amplify, and filter small bio potential signals in the presence of noisy conditions. This design allows for an ultra low power analog-to-digital converter or an embedded micro controller to acquire the output signal easily. The AD8232 can implement a two-pole high-pass filter for eliminating motion artifacts and the electrode half-cell potential. This filter is tightly coupled with the instrumentation architecture of the amplifier to allow both large gain and high-pass filtering in a single stage.

### C. Micro controller

We use ARDUINO NANO board for it's feasibility and simplicity. It employs ATMEGA328 microcontroller. It is programmed in embedded C using Arduino IDE. After the amplification and the filtering process the Arduino will process the signals and give the output according to the

specific algorithm. The Arduino will do the following operations:

1. Will take the analog signal data from the ICAD8238 and process it according to the working specified.
2. The Arduino will send the control signal to the device that is to be controlled.

5. If we blink a certain number of times in a certain interval of time, the micro controller will enable the relay switches.

6. Depending on which relay switch is provided with the control signal, the respective device turn on.

7. The number of blinks and the interval can be decided by the user.

As an example, if we blink 2 times in 9 seconds then the relay one will get the control signal and the device which is connected to relay 1 will operate.

The above logic can also be implemented using machine learning, which will greatly reduce the error of the system.

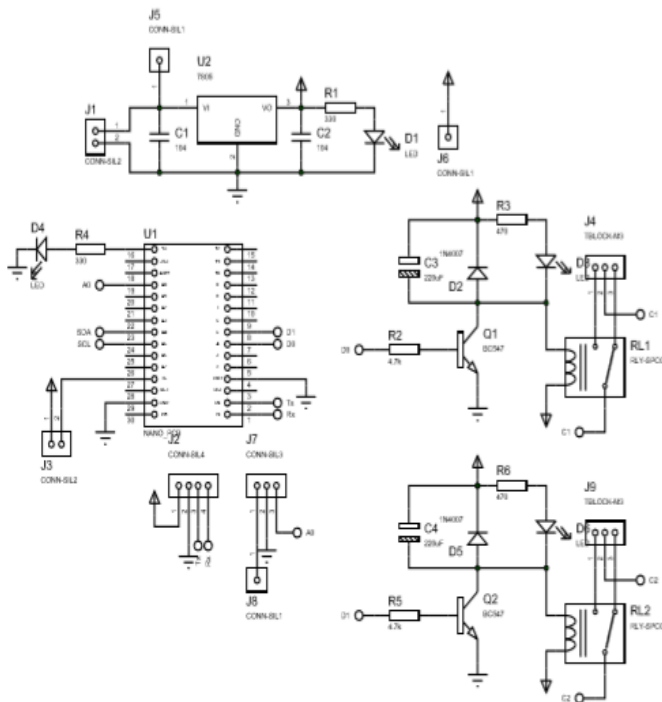

Fig -2: Circuit Diagram



Fig -3: Hardware

### 3. WORKING

Our BCI system captures the electrical signals from the forehead position. The electrodes will then send the signals to the amplifier and filter circuit wherein the signal is amplified and unwanted noise and signals are filtered out. The analog signals are then converted into digital signals by the inbuilt ADC of Arduino. Since the electrical signals are taken from the forehead position near the eyes, they contain data regarding the eye movement. Thus we obtain the eye blink count from the obtained electrical signal. The micro controller process the signals based on the following logic:

1. Whenever we blink, EEG waves will encounter a peak.
2. This peak value is set as threshold value.
3. If we blink, the output of the ADC goes beyond the threshold value, the Arduino counts it as a blink.
4. The moment we blink, the timer of the microcontroller will start.

### 4. CONCLUSIONS

It is quite probable that in the future most of our appliances will be controlled directly through our wishes or the brain and this project stands as an affirmation to that vision. Signals from the brain can be further studied and the technology can be refined to bring about more specific results. The scope of the project was primarily to establish control through no physical motion on part of the user and it has been successful in doing so but it has also laid a foundation for many applications which would greatly improve the standard of life for all.

### ACKNOWLEDGEMENT

It is a great pleasure to acknowledge all those who have assisted and supported us for successfully completing our project.

First of all, we thank God Almighty for his blessings as it is only through his grace that we were able to complete our project successfully.

We are deeply indebted to Dr. Soosan George T, Principal, and Mar Athanasius College of Engineering for her encouragement and support.

We express our deep sense of gratitude to Prof. Acy M Kottalil, Head of Electrical & Electronics Engineering Department, for the valuable guidance as well as timely advice which helped in a lot in doing the project successfully.

We also extend our deep sense of gratitude to our Project coordinator and Faculty Advisor Prof. Neena Mani, Assistant Professor, Electrical & Electronics Engineering Department for her creative suggestions during the preparation of the project.

We take this opportunity to extend our sincere thanks to our project guide Prof. Veena Mathew, Assistant Professor and all the members of the Department of Electrical & Electronics Engineering for sharing their valuable comments during the preparation of the project.

We whole - heartedly thank all our classmates, for their valuable suggestions and for the spirit of healthy competition that existed between us

## REFERENCES

- [1] Gerwin Schalk and Eric C. Leuthardt, "Brain-Computer Interfaces Using Electrocorticographic Signals," IEEE Reviews In Biomedical Engineering, vol. 4, October 2011
- [2] J. R. LaCourse and F. C. Hludik, An eye movement communication controls system for the disabled, IEEE Trans. Biomed. Eng., vol. 37, pp. 1215-1220, 1990
- [3] Luzheng Bi, Xin-An Fan, and Yili Liu, EEG-Based Brain-Controlled Mobile Robots: A Survey, IEEE Transactions On Human-Machine Systems, vol. 43, no. 2, March 2013.
- [4] A. Keirn and J. I. Aunon, Man-machine communications through brain-wave processing, IEEE Eng. Med. Bio. Mag., vol. 9, pp. 55-57, 1990.