

ELECTRIC POWER MANAGEMENT USING ZIGBEE WIRELESS SENSOR NETWORK

Kinnal raval¹, nidhi shah², vrunda prajapati³, Prof. Abhishek Patel⁴

^{1,2,3} Students, Department of Electrical Engineering, Vadodara institute of engineering, Kotambi, Vadodara-390018, Gujarat, India

⁴Assistant professor, Department of Electrical Engineering, Vadodara institute of engineering, Kotambi, Vadodara-390018, Gujarat, India

Abstract - The main aim of our topic is that will differentiate and to control the devices on the basis of power consume by the loads and their demand for efficient use of electrical power. The controlling device or transmitter will compare the threshold value and the end device or receivers will control the loads. The advantage of x-bee sensor is that it's very long battery life, long range, Mesh networking allows very reliable data transfer, Uses direct spread spectrum technique, 2 to 65535 devices per network, sleep mode sensor and duty cycle is low as compared to Bluetooth and other wireless communication devices.

suitable for operation in harsh radio environments and in isolated location

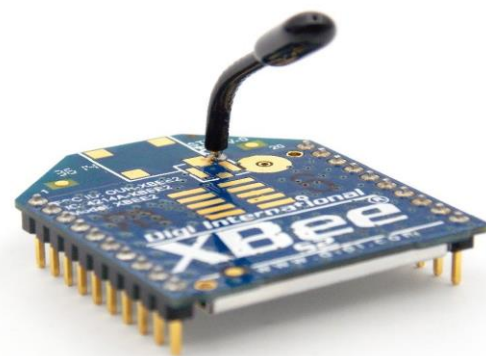

Fig-1: Zigbee module

Keywords: Zigbee, arduino, power management

1. INTRODUCTION

As we know that we can't get proper regulated power distribution because of many reasons. The world's big issue is only that the unequal power transfer. So that many researchers expect existing energy production capabilities will fail to meet future demand without new sources of energy, including new power plant construction. Instead of that solutions ignore another attractive alternative which is to slow down or decrease energy consumption through the use of technology to dramatically increase energy efficiency. To overcome this problem we make system like whenever lights gets cut off suddenly and it is interrupted for some time then small loads are automatically in on state condition but big loads may off for time when lights recovers itself. Using some wireless sensor x-bee protocol we make that methodology. It is very easy to understand and for economically it may also moderate. We create a wireless sensor network having number of nodes which communicate with each other in full duplex mode. Here we using the x-bee wireless communication so its main point is that x-bee is require very less power, we can operate that sensor using battery too. There are one controlling and one end devices for managing the power. The loads are controlled by end devices and this project will differentiate and to control the devices on the basis of power consume by the loads and their demand for efficient use of electrical power.

The main advantage of using Zigbee protocol is that require very less amount of power so it can be operated from battery. It is easy to control and monitor the home appliances. It is easy to add/remove the Zigbee end device

It is open-loop sensor and low power consumed device.

1. It is manage 2 to 65535 devices at a time.
2. Fully static operation up to 0HZ to 33MHZ
3. It has 256*8 bit internal ram
4. It has 32 programmable I/O lines.

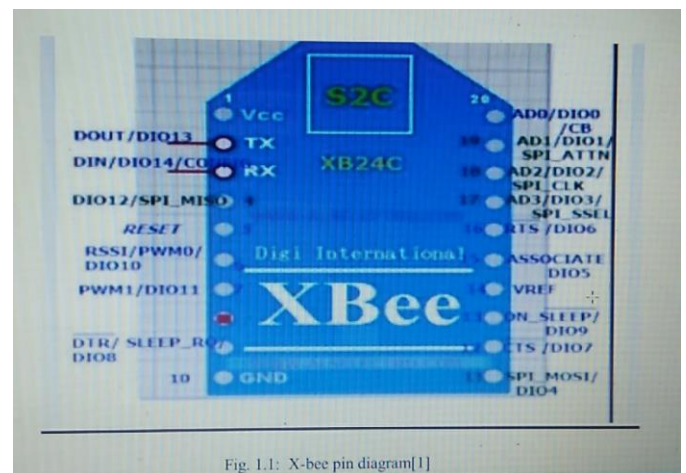

Fig. 1.1: X-bee pin diagram[1]

1.1 What is Zigbee?

Fig 1 shows the is a wireless networking standard that is aimed at remote control and sensor applications which is

Fig-2: zigbee pin diagram

1.2 How to configure Zigbee module:

- XCTU is a free multi-platform application designed to enable developers to interact with Digi RF modules through a simple-to-use graphical interface. It includes new tools that make it easy to set-up, configure and test XBee RF module.
- XCTU includes all of the tools a developer needs to quickly get up and running with XBee. Unique features like graphical network view, which graphically represents the XBee network along with the signal strength of each connection, and the XBee API frame builder, which intuitively helps to build and interpret API frames for XBee being used in API mode, combine to make development on the XBee platform easier than ever.

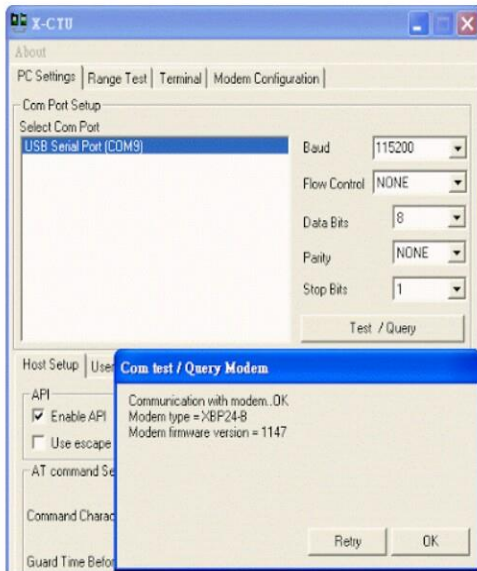

Fig 3.8 X-CTU display

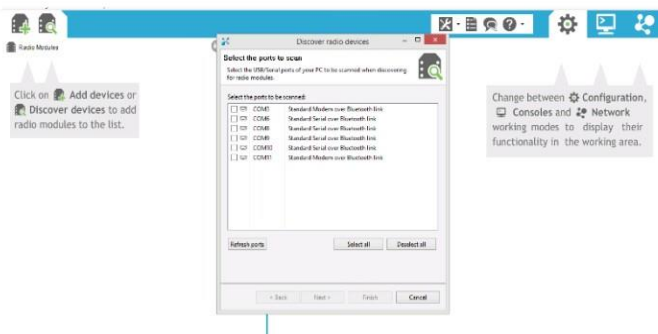

Fig-3: xctu display

- Other highlights of XCTU include the following features:
1. You can manage and configure multiple RF devices, even remotely (over-the-air) connected devices.

2. The firmware update process seamlessly restores your module settings, automatically handling mode and baud rate changes.
3. Two specific API and AT consoles, have been designed from scratch to communicate with your radio devices.
4. You can now save your console sessions and load them in a different PC running XCTU.

2. BLOCK DIAGRAM

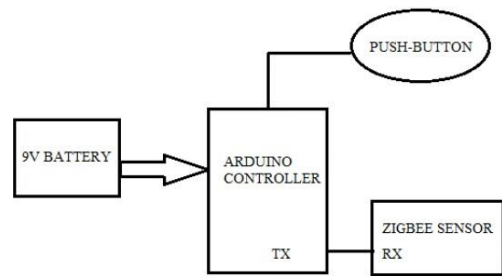

Fig-4: block diagram (control circuit)

1) Control circuit

- The above scheme represents the control circuit (transmitter) of our project.
- Here, the arduino controller is connected with Zigbee module by TX terminal of arduino with RX of Zigbee because firstly we have to send some data by arduino controller.
- Now the arduino gets receive supply by 9v battery and its connection is shown above scheme.
- Here we have connected 1 to 7 push-button from arduino side for remotely turn on and turn off different loads by feeding the program into controller. There are 7 resistors is also attached with push-button. Now the push-button is acts like switches.
- So here we are simply managing the power of different load by the control circuit.
- Now we are move towards power circuit (receiver).

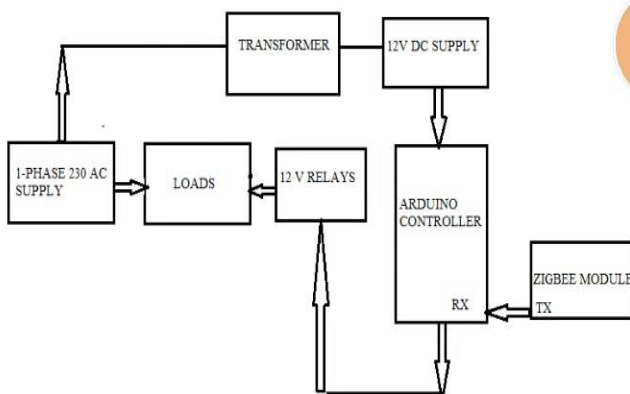

Fig-5: block diagram (power circuit)

2) POWER CIRCUIT

- The above scheme represents the power circuit (receiver) of our project.
- Here, arduino controller of RX terminal is connected with TX of Zigbee module because now we have to receive the serial data that comes from transmitter circuit.
- Now the 12 volt dc supply is made with the help of bridge rectifier, diodes, relay driver IC UNL2003, and led. By connecting 12v step-down transformer the 230 AC supply is step-down at 12 v and it is given to 12v dc supply it will convert in dc supply and given to the arduino. So that arduino gets supply from it.
- Now 12v relays are connected for controlling devices and its power here are connected total 7 relays so that at a time we are managing the 7 different loads of power.
- 1-phase 230 AC supply is applied to the loads whose power management we have to require to control.
- There are 2 set of Zigbee module and arduino controller. One set represents the transmitter and another set represents the receiver. The 12 v relay is connected with receiver set of arduino controller for controlling purpose, power supply is 12 v is apply to the relay set.
- Ac load is operating with help of relay switch on and off.
- There is another method for controlling the receiver set by using direct Zigbee remote controller. Using that we apply the direct signal to the receiver set and controls it. But here we used second option that is separate set of Zigbee and arduino controller.

3) Combination of both (concept) diagrams



2.1 FUNCTION OF DIFFERENT COMPONENT

Zigbee module: - It uses the Zigbee protocol to communicate with the arduino controller. It consists of transceiver, receiver and Zigbee stack implemented in it

Arduino controller: - It is a simple micro controller board. It can used to make computers. It is used for access serial port. It does not need to access the register details. It can simply perform call the functions and easily perform the coding and debugging

12V Relay:-here double pole single action relay is used. It has normally open and normally closed connections. We are connecting arduino controller with normally open connections. One pin is connecting with relay driver circuit and other pin that is variable terminal is connecting with 18v battery of positive terminal.

Load: -here we used 15 watt bulb for perform the operation by Zigbee module. Its positive terminal connects with normally open pin of 12v relay and negative terminal of bulb is connecting with battery

Transformer:-here we are using 230-12v step down transformer for applied the supply to arduino controller. It will consume 1mili amp current from supply and it is connected to 12v dc supply for transfer power from ac to dc.

3. SIMULATION

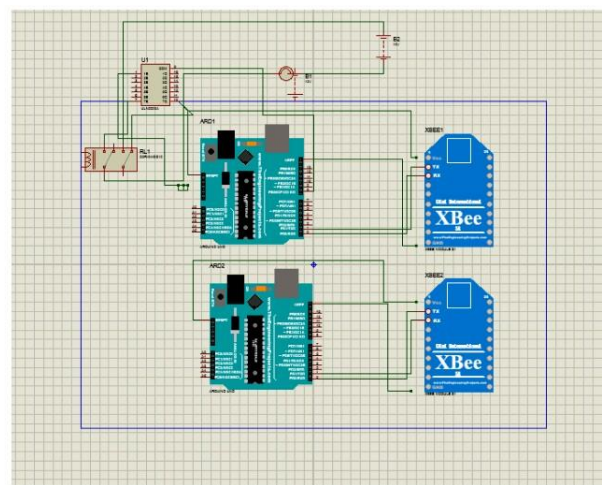

Fig-6: simulation work

-
- Complete implementation of our project is shown in figure

below:

- From the above figure it is shown that the x-bee is interfacing with arduino and as a receiver. The another pair of x-bee and arduino is works as the transmitter. Firsty and transmitter receives the input signal and give the another pair of x-bee and arduino of receiver. it will receive the command and according to task it perform the operation.
- Here, the arduino controller is connected with Zigbee module by TX terminal of arduino with RX of Zigbee because firstly we have to send some data by arduino controller.
- Now the arduino gets receive supply by 9v battery and its connection is shown above scheme.
- Here we have connected 1 to 7 push-button from arduino side for remotely turn on and turn off different loads by feeding the program into controller. There are 7 resistors is also attached with push-button. Now the push-button is acts like switches.
- So here we are simply managing the power of different load by the control circuit.
- Now we are move towards power circuit (receiver). Here, arduino controller of RX terminal is connected with TX of Zigbee module because now we have to receive the serial data that comes from transmitter circuit.
- Now the 12 volt dc supply is made with the help of bride rectifier, diodes, relay driver IC UNL2003, and led. By connecting 12v step-down transformer the 230 AC supply is step-down at12 v and it is given to 12v dc supply it will convert in dc supply and given to the arduino. So that arduino gets supply from it.
- Now 12v relays are connected for controlling devices and its power here are connected total 7 relays so that at a time we are managing the 7 different loads of power.
- 1-phase 230 AC supply is applied to the loads whose power management we have to require to control.
- There are 2 set of Zigbee module and arduino controller. One set represents the transmitter and another set represents the receiver. The 12 v relay is connected with receiver set of arduino controller for controlling purpose, power supply is 12 v is apply to the relay set.
- Ac load is operating with help of relay switch on and off.
- There is another method for controlling the receiver set by using direct Zigbee remote controller. Using that we apply the direct signal to the receiver set and controls it. But here we used second option that is separate set of Zigbee and arduino controller.
- From the above circuit we are able to control the power of one room or laboratory's of all the devices like tube lights, fans, bulbs etc.
- The 12v relay also connected with arduino and it will break or make the circuit according to command. So from arduino software we are making the programming and then load that program into arduino board and managing the power of resistive load.we are selected com port of x-bee from its software that is x-ctu. It is the digi software. It will used for start the communication of

x-bee.

5. IMPLEMENTATION



Fig-7: control circuit

- In this figure it is a transmitter circuit. It is a work as a remote control. One Arduino and Zigbee module is connected.
- In this transmitter side power supply is battery 9 v.
- Push button is connected at the end, and resistor is connected across the push button.
- The 7 pushbutton is connected across 7 resistors for controlling the device's power.
- The pin no 2 to 9 pins of arduino is taken as input pins and 13 no pin is taken as output pin.
- The TX of arduino is connected with RX of Zigbee and Vcc and ground pins of arduino are connected in Zigbee of 3.3v supply and ground.

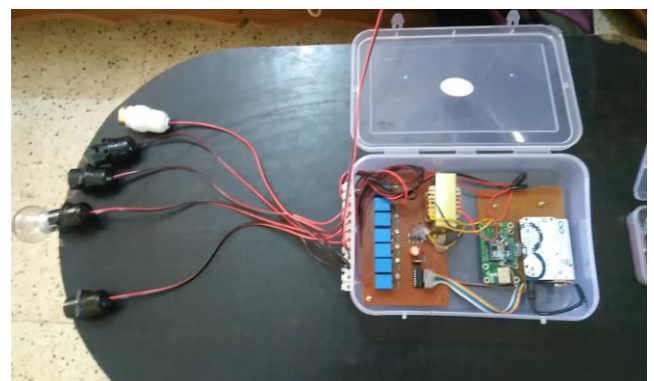

Fig-8: power circuit

- Fig is a receiving side circuit. in this the circuit we are made 12 v power supply

- 230 v ac supplies are given to the ac load and also apply to the 12 v transformer and this transformer is step down the voltage to 12v
- Bridge circuit or rectifier is convert ac supply into dc supply and dc supply is given to the relay driver IC.
- Relay work on the dc supply, and interface with Arduino.
- We are connecting 7 loads across the relay.
- Arduino and Zigbee are connected, and Arduino is work on 5v supply.

When the transmitting side push button is pressed, so respective relay is on and the loads that is connected to outside of the circuit it also gets turn on with the help of programming feeding into it, Other Wise it is turn off.



Fig-9: total implementation

5) ADVANTAGES

- Using arduino controller the understanding and making the programming is easy.
- Flexibility is increase because of x-bee interfacing with arduino.
- Lower maintenance.
- Harmonics are reducing.
- Mesh networking allows very reliable data transfer.
- Uses direct spread spectrum technique.
- 2 to 65535 devices per network.
- Very compact and not affected by climatic conditions.
- It is economically good and reliable product.

6) APPLICATION

- Used in smart grid transmission line.
- Used in smart home automation topology.
- Used in every wireless machines and other scheme.
- Used in robotics , wireless power transfer scheme.etc

7) UNIQUE FEATURE

There are very unique features:

- 1) Utilities and consumers both benefit from more accurate billing that is available, thanks to the increased granularity of

usage information, for example, for individual floors, apartments, or offices within a building.

- 2) This gives consumers better control of their power and water usage, and passes on the biggest savings to those who use these services most efficiently.

- 3) It also helps to reduce the number of billing enquiries, and helps to make those enquiries easier to resolve.

8) FUTURE SCOPE

Utilities have more at hand about outages and restorations, and are able to provide consumers with good information about when power will be restored. During emergencies, utilities can create "partial outages" in non-exempt buildings to ensure the power remains available where it is most needed. Partial outages are more economically efficient than full rotating outages, because the effects are limited to the reduction of a single discretionary service such as air conditioning rather than the elimination of all services. Also power factor improvement can result in a lot of power saving for industrial sector.

5. CONCLUSION

From the above product we are able to conclude that using higher number of string of X-bee module we manage the power for no of devices at a time.X-bee's wireless open standard technology is being selected around the world as the energy management and efficiency technology of choice. Implementing smart meters with an open standard such as X-Bee helps to keep costs down, ensure interoperability, and future-proof investments made by both utilities and consumer.

REFERENCES

- [1] Qixun Yang, Board Chairman, Beijing Sifang Automation Co. Ltd., China and .Bi Tianshu, Professor, North China Electric Power University, China. (2001-06-24). "WAMS Implementation in China and the Challenges for Bulk Power System Protection" (PDF). Panel Session: Developments in Power Generation and Transmission — Infrastructures in China, IEEE 2007 General Meeting, Tampa, FL, USA, 24–28 June 2007 Electric Power, ABB Power T&D Company, and Tennessee Valley Authority (Institute of Electrical and Electronics Engineers). Retrieved 2008-12-01.
- [2] [Jones01] Christine E. Jones, Krishna M. Sivalingam, Prathima Agrawal, Jyh Cheng Chen. A Survey of Energy Efficient Network Protocols for Wireless Networks. Wireless Networks. Volume 7, Issue 4 (August 2001). Pg. 343-358. ISSN:1022-0038
- [3] Yilu Liu, Lamine Mili, Jaime De La Ree, Reynaldo Francisco Nuqui, Reynaldo Francisco Nuqui (2001-07-12). "State Estimation and Voltage Security Monitoring Using Synchronized Phasor Measurement" (PDF).

Research paper from work sponsored by American Electric Power, ABB Power T&D Company, and Tennessee Valley Authority (Virginia Polytechnic Institute and State University) Retrieved (2008-12-01). Abstract lay summary. ""Simulations and field experiences suggest that PMUs can revolutionize the way power systems are monitored and controlled.""

[4] Olaf Stenull; Hans-Karl Janssen (2001). "Nonlinear random resistor diode networks and fractal dimensions of directed percolation clusters". Phys. Rev. E 6435 (2001) 64.

[5] Jivan SP, Shelake VG, Kamat RK, Naik GM (2002). "Exploring C for microcontrollers" ISBN 987-1-4020-8392:4-5.

[6]Thaddeus J (2002). Complementary roles of natural gas and coal in Malaysia, Proceedings of the 8th APEC Coal Flow Seminar/9th APEC Clean Fossil Energy Technical Seminar/4th APEC Coal Trade, Investment, Liberalization and

[7] Vito Latora; Massimo Marchiori (2002). "Economic Small-World Behavior in Weighted Networks". European Physical Journal B 32 (2): 249-263

[8] Vito Latora; Massimo Marchiori (2002). "The Architecture of Systems".

[9] [Karl03] Holger Karl. An Overview of Energy-Efficiency Techniques for Mobile Communication Systems. TKN Technical Reports Series. Technische Universities Berlin, 2003.
http://www.tkn.tuberlin.de/publications/papers/TechReport_03_017.pdf

[10] U.S. Department of Energy, Office of Electric Transmission and Distribution, "Grid 2030" A National Vision for Electricity's Second 100 Years, July 2003