

AOT BASED ESCALATOR IN PUBLIC TRANSPORT FOR PHYSICALLY DISABLED PERSON

ANUSUYA M¹, DHANSIRA BANU H², KEERTHANA G³, RAMYA S⁴, KARTHIKEYAN V⁵

¹²³⁴Student ⁵Assistant Professor

¹²³⁴⁵Department of Electronics and Communication Engineering

¹²³⁴⁵Vivekanandha College of Engineering for Women

Abstract- Accessibility is important in daily life especially when dealing with external and internal environment. Realizing that most public transport terminals still lack in terms of good design and facilities thus a serious concern for the matters is needed to ensure the convenient for all. It has been widely accepted that disabled people, have fewer opportunities and lower quality of life than non-disabled. Added with poor accessibility, the disabled people face more challenges and difficulties while travelling and using the public transport. Therefore, it becomes increasingly difficult to ignore the disabled issues while using the facilities of the public transport. In this project we have to implements the some technical facility for these type of people. In this paper, we design an escalator for disabled person with some technical facility for their convenience using AOT, GPS and Fingerprint Recognition.

also when bus meets with an accident, nearby hospitals and ambulances get alert with the location of the bus by using GPS.

WORKING PRINCIPLE

In its working the PIC microcontroller (16F877A) controls the circuit and through the power supply +4v (Vcc). The circuit contains three DC motors the first dc motor controls the pic microcontroller through the power supply. The second dc motor controls the finger print sensor board and the third dc motor controls the escalator. The Finger print sensor has two switches the one switches to save the persons data and another one is to search the data. LCD displays the name of whose finger print is after recognized. Limit sensor or vibration sensor is implemented in front of the bus. In case of any accident, GPS will find the location and sends the message to nearby hospitals. An android app "Blue act and Blue term" is used. The app blue term is used to connect the Bluetooth between circuit and the mobile. The app blue act is used to send the message to the responsible persons like doctor, ambulance and home.

INTRODUCTION:

Almost everyone will face temporary or permanent disability at some point in life; there are also people with limited mobility caused by a number of factors, such as disease or accidents. Others who live old age will likely experience increasing difficulties in functioning and many can experience disability. The first World Report on Disability (2011) produced jointly by the WHO and the World Bank suggests that more than a billion people in the world today has some form of disability. Improved access and mobility are important factors in reducing poverty and can facilitate the participation of people with disabilities in economic, social and political processes. Physical accessibility will also benefit people who are not disabled but have limited mobility, including elderly, children, and pregnant women. Exclusion increases the costs associated with disability and people who are denied access to essential transport services tend to face greater challenges to stay out of the poverty cycle. Infrastructure investments are being made. In most cases, following requires attention and good design, not extra cost. In this paper, we are redesigning public transport with some technical facilities for the convenience of disabled persons and people with limited mobility. Here, we are designing a escalator and also using AOT for knowing the status of bus. It also has extra features which are really helpful during emergency like When a person falls ill during travel, Biometric is used to send medical information of ill person to the nearby hospital before we reach the hospital and

BLOCK DIAGRAM

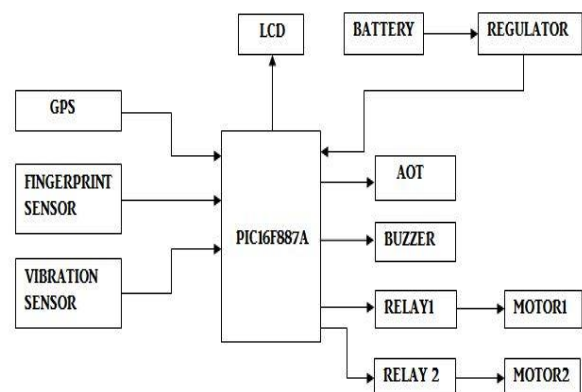

HARDWARE SPECIFICATION:

PIC16F877:

PIC16F877 belongs to a class of 8-bit microcontrollers of RISC architecture. It has 8kb flash memory for storing a

written program. Since memory made in FLASH technology can be programmed and cleared more than once, it makes this microcontroller suitable for device development. It has data memory that needs to be saved when there is no supply. It is usually used for storing important data that must not be lost if power supply suddenly stops. For instance, one such data is an assigned temperature in temperature regulators. If during a loss of power supply this data was lost, we would have to make the adjustment once again upon return of supply.

BATTERY:

An electric battery is a collection of one or more electrochemical cells in which stored chemical energy is converted into electrical energy. The principles of operation haven't changed much since the time of Volta. Each cell consists of two half cells connected in series through an electrolytic solution. One half cell houses the Anode to which the positive ions migrate from the Electrolyte and the other houses the Cathode to which the negative ones drift. The two cells are may be connected via a semi permeable membranous structure allowing ions to flow but not the mixing of electrolytes as in the case of most primary cells or in the same solution as in secondary cells.

CONVEYOR:

A conveyor belt is the carrying medium of a belt conveyor system (often shortened to belt conveyor). A belt conveyor system is one of many types of conveyor systems. A belt conveyor system consists of two or more pulleys (sometimes referred to as drums), with an endless loop of carrying medium—the conveyor belt—that rotates about them.

DC MOTOR:

Electrical motors are everywhere around us. Almost all the electro-mechanical movements we see around us are caused either by an AC or a DC motor. Here we will be exploring this kind of motors. This is a device that converts DC electrical energy to a mechanical energy.

FINGER PRINT RECOGNITION

Finger print recognition or fingerprint authentication refers automated method of verifying a match between two human fingerprints. Fingerprints are one of many forms of biometrics used to identify individual verify their identity.

GPS:

The GPS is a space-based satellite navigation system that provides location and time information in all weather conditions, anywhere on or near the Earth where there is

an unobstructed line of sight to four or more GPS satellites. The system provides critical capabilities to military, civil and commercial users around the world.

LCD:

LCD (Liquid Crystal Display) screen is an electronic display module and find a wide range of applications. A 16x2 LCD display is very basic module and is very commonly used in various devices and circuits.

RELAY:

Relays are simple switches which are operated both electrically and mechanically. Relays consist of an electromagnet and also a set of contacts. The switching mechanism is carried out with the help of the electromagnet. There are also other operating principles for its working. But they differ according to their applications. Most of the devices have the application of relays.

VIBRATION SENSOR:

A vibration sensor is a device which senses vibration and converts it into an analog electric signal whose magnitude depends upon the vibration applied. Since they convert vibration into an electrical signal, they are also termed as vibration transducers.

SOFTWARE SPECIFICATION:

MPLAB IDE

MPLAB IDE is a software program that runs on a PC to develop applications for Microchip Microcontrollers. It is called an Integrated Development Environment, or IDE, because it provides a single integrated "environment" to develop code for embedded microcontrollers.

HI-TECH C compiler

HI-TECH Software is a world class provider of development tools for embedded systems, offering compilers featuring Omniscient Code Generation™, whole-program compilation technology, and an Eclipse-based IDE (HI-TIDE™) for 8-, 16-, and 32-bit microcontroller and DSC chip architectures.

COMMANDS USED IN GSM MODEM

Receiving SMS messages using AT commands
AT+CMGF=1 <ENTER> If the modem responds with "OK" this mode is supported. Please note that using this mode it is only possible to send simple text messages. It is not possible to send multipart, Unicode, data and other types of messages.

Setting up the modem:

In order to send a SMS, the modem has to be put in SMS text mode first using the following command:

```
AT+CMGF=1 <ENTER>
```

If the modem responds with error, either the modem does not support SMS text mode, or the SIM card is not ready. In this case please check that the SIM card is inserted and the pin code is entered.

Reading a message

To list a single message, you have to use the read command. You must use the list command first, so you know the indexes of the messages in the storage. For instance, to read the message on memory location '2' use:

```
AT+CMGR=2 <ENTER>
```

The modem will list the single message:

```
+CMGR: "READ", "+31625012254", "07/07/05,09:56:03+08" "REC
```

Test message 2

OK

Send SMS using AT commands

Some advanced GSM modems like Waveform and Multitask, support the SMS text mode. This mode allows you to send SMS messages using AT commands, without the need to encode the binary PDU field of the SMS first. This is done by the GSM modem

To check if your modem supports this text mode, you can try the following command:

```
AT+CMGF=1 <ENTER>
```

If the modem responds with "OK" this mode is supported. Please note that using this mode it is only possible to send simple text messages. It is not possible to send multipart, Unicode, data and other types of messages.

Sending the message:

```
AT+CMGS="+31638740161" <ENTER>
```

Replace the above phone number with your own cell phone number. The modem will respond with:

>

You can now type the message text and send the message using the <CTRL>-<Z> key combination:

```
Hello World ! <CTRL-Z>
```

After some seconds the modem will respond with the message ID of the message, indicating that the message was sent correctly:

```
+CMGS: 62
```

CONCLUSION

We have implemented an escalator in public transport to help people with disability to access public transport with ease. In addition to that we have also implemented accident alerting and location tracking system using GPS and AOT. Accident detection is also included to acknowledge the accident location via. GSM system, to provide immediate assistance for victims. We have also implemented health monitoring system that gets the medical information of the patient by using fingerprint sensor and AOT. The results taken are from prototype-level implementation for public transport system (bus). The results taken are at real time and help to improve a safe and smart system in the field of automation. The work can be expanded for various public domain facilities such as in transportation of trucks and vans. The work can also be developed for private sector where single user can implement the system for its safety and system advancement. Then, the work in the system for automatic steering operation and upper-dipper implementation to avoid accidents at night time on highways can also be done.

REFERENCE

- 1) Asritha Garapati, Peddi Anudeep, "Implementation of Smart Public Transport System Using ARM7TDMI-S Processor and GPS-GSM Technologies", International Journal of Science and Research (IJSR), Volume 3 Issue 9, September 2014.
- 2) Dhivya M and Kathiravan S, "Driver Authentication and Accident Avoidance System for Vehicles", Smart Computing Review, vol.5, no.1, February 2015.
- 3) Joseph Andrew Giampapa, Aaron Steinfeld, Ermine Teves, M. Bernardine Dias, Zachary Rubinstein,
- 4) Nanaware sonali. M, Prof.Mantri D.B., "Smart Assistance Public Transport System", International Journal of Research Publications in Engineering and Technology, Volume 3, Issue 9, September 2017.
- 5) Parag Gawade, Prof.Meeankshi A, IOT Based Smart Public Transport System, International Journal of Scientific and Research Publications, Volume 7, Issue 7, July 2017.
- 6) Pengfei Zhou, Student Member, IEEE, Yuanqing Zheng, Student Member, IEEE, and Mo Li, Member, IEEE, "How Long to Wait? Predicting Bus Arrival Time With Mobile Phone Based Participator Sensing", IEEE Transactions on Mobile Computing, vol.13, no. 6, June 2014.

7) Pratiksha Bhuta, Karan Desai, Archita Keni, "Alcohol Detection and Vehicle Controlling", International Journal of Engineering Trends and Applications (IJETA) -Volume 2 Issue 2, Mar-Apr 2015.

8) SeoJuLee, Girma Tewolde, Jaerock kwon, "Design and Implementation of Vehicle Tracking System using GPS/GSM/GPRS Technology and Smartphone Application", IEEE world Forum on Internet Of Things (WFIoT), March 2014, Seoul.

9) Ramya Keerthi C.H, Shanmukh.G, Dr. R. Sivaram, "Various Accident Detection Technologies and Recovery Systems with Victim Analysis", International Journal of Advanced Trends in Computer Science and Engineering (IJATCSE), Vol.2 , No.3, Pages : 07-12 (2013) Special Issue of ICCSIE 2013 - Held during 24 May, 2013 Bangalore.

10) Reshma Rathod, Associate. Prof. S.T.Khot, "Smart Assistance for Public transport system", IEEE Transactions on Intelligent Transportation Systems Volume : 8, Issue: 1, March 2007.