

MEASURING ELECTRICITY CONSUMPTION OF APPLIANCES AND MONITORING THEM USING IoT AND MACHINE LEARNING

Jalpa Patel¹, K. Avinash Reddy², M. Kirti³, Dr. D. B. K. Kamesh⁴, Dr. J. Sasi Bhanu⁵

^{1,2,3}Student of B. Tech Computer Science and Engineering,

⁴Head of Department Computer Science and Engineering,

⁵Professor of Computer Science and Engineering.

St. Martin's Engineering College, Hyderabad, Telangana 500014.

Abstract - Electricity usage has increased exponentially over the past two decades. Due to this level of usage, the increase in the electricity bill is inevitable. The electricity resources in the current world are mostly non-renewable and hence are getting depleted at an alarming rate and a scenario like this calls for an immediate attention. Many units of power are being wasted due to negligent usage in residential parts of India every year. Most of this wastage can be ceased by proper monitoring of usage. The proposed system uses magnetic induction principle to know the energy readings from one place of the house. The sensor used is a clammer that is fixed around the MCB, and the readings are obtained over the internet. The readings are stored in the cloud using WIFI module. Electricity consumption of individual appliances is obtained by using machine learning algorithms. The usage is then compared with a threshold level of that appliance. The readings help us know if the electricity consumption is more or less than required. The users are notified using a mobile application. In this application, the user can view the electricity usage and monitor it continuously. The estimated cost of the electricity used can also be known from the application. The cost can be known at any point from the start of the month. The application notifies the users, which appliance is using more electricity and suggests some tips to monitor the electricity usage. If an appliance is not in use but still powered on, then the user can turn it off from a remote place.

Key Words: IoT, Machine Learning, Electricity Monitoring, Clammer, NodeMCU, Arduino, Relay.

1. INTRODUCTION

Out of the total electricity produced a share of 65.8% is held by fossil fuels. Reserves of fossil fuels are fast depleting and the rate at which they are depleting, everyone must take steps towards conservation of electricity. The electricity consumption rate increases by 7% every fiscal year.

With the increase in dependency on electrical appliances, the consumer doesn't know why his electricity bill is being too high than expected. An obvious reason for this being that most of the appliances are still consuming power even though it's not required. The provider of electricity also must manually go to every home for checking the final bill. The answer for each of these problems is to keep a track of the consumers' electricity consumption.

The present undertaking "MEASURING ELECTRICITY CONSUMPTION OF APPLIANCES AND MONITORING THEM USING IoT AND MACHINE LEARNING" addresses the issues of consumers and also focuses on the conservation of natural resources. The paper focuses on the key importance of knowing and understanding the electricity consumption by individual appliances at our homes. The consumer prefers to spend less on electricity and other utilities to increase their savings. Hence knowing how much electricity has been consumed and what is it going to cost us addresses a huge portion of the consumers' problem. This is done by integrating the hardware and the software. The microcontroller used for the demonstration of this project is Arduino UNO and this is connected to the WIFI module which is NodeMCU. The special sensor used to measure current values is the SCT 013 sensor. The key advantage of using this sensor is that it doesn't involve changing of wires in the household. It can be clamped around the phase wire at our homes.

The values of electricity consumed by individual appliances at our home are retrieved on the mobile application which is taken from the cloud with the help of the WIFI module. These values are taken from the phase wire are categorized into different appliances by using the Machine Learning Algorithms. The application first trains for the existing appliances and then constantly shows the values of the electricity consumed. Finally, after studying the usage patterns of the devices the application turns off a device by user permission if it's currently not in use. This is done with the help of relay drivers attached to the appliances.

This framework helps us to minimize the electricity bills by up to 40%. This can be ensured if we track every appliance and check if it is getting the right amount of energy. This framework if utilized properly helps us in saving electricity and to minimize the cost.

2. LITERATURE SURVEY

India shares 8% of world's coal reserve, hence we need to manage the use of coal. Reports reveal that these fossil fuels might last up to 2030. Hence, based on the statistics we need to monitor our usage of these fossil fuels. This project, therefore, helps in tracking use of electricity consumption and turning off the appliances when we are away, and which are not in use.

The current existing solutions which can be used to measure the electricity consumption of an appliance are Kill – A – Watt meters, Clamp Meters, Smart Plugs or Smart Switches.

Kill A Watt meters are special devices which help us learn the amount of current being consumed by an appliance. The drawback of this product is that we need to plug individual devices every time to learn the consumption readings of that appliance.

We have smart switches or smart plugs which are being manufactured by well-known companies like Belkin. Belkin has a smart plug called WeMo Insight Smart Plug. This is connected to WIFI and lets you know what device has been connected to it and you can determine the cost on your phone directly with the accessibility of the plug from a remote place.



Fig -1: Kill A Watt Meter



Fig -2: Clamp Meter



Fig -3: Smart Plug

3. OVERVIEW OF THE SYSTEM

The current system has hardware and software components. The hardware consists of the device to monitor electricity usage and the circuit for powering off the devices when they are not in use. The software part of the system consists of a mobile application which shows the data regarding the electricity consumption by different appliances. It shows the cost incurred between the two dates entered.

3.1 ARCHITECTURE

The architecture of the system is as shown in Fig. 4. The device is connected to the MCB of the home. This device has Arduino UNO as the microcontroller and it uses a WIFI module ESP8266. There is another microcontroller used to connect the relays. These relays help us power off devices which are not in use. This can be done from a remote place as well. Explanation of the architectural model is as follows:

- When various appliances of the household consume electricity the Current (CT) sensor monitors it and the data is then updated on the cloud.
- This data is given to the machine learning algorithm to study its usage patterns.
- After the algorithm has studied its consumption patterns, it checks if the range of consumption is within the threshold limit. If not, it will alert us.
- Using the values, the Watt of electricity consumed can be known in the mobile application.
- In the application, the user can check the electricity consumption of individual rooms and individual appliances.
- It gives statistics of electricity consumed by the individual appliance.
- The cost for the same can be calculated.
- To calculate the cost, we must enter the start and end date, it will display the cost of electricity consumed.

If we don't want to run a device, then we can even turn it off using the mobile application.

This architecture helps the user know the reasons behind their electricity bills. And they can clearly track and monitor their usage. This system learns the usage patterns and it automatically operates the devices. To consider a case of AC, it will study the usage patterns of AC, at what temperature it has been used and for what time. It will learn this data for a week, and then it will automatically power on and off the AC without human interference. The same can be applied to other appliances at home like geysers and fridge if required.

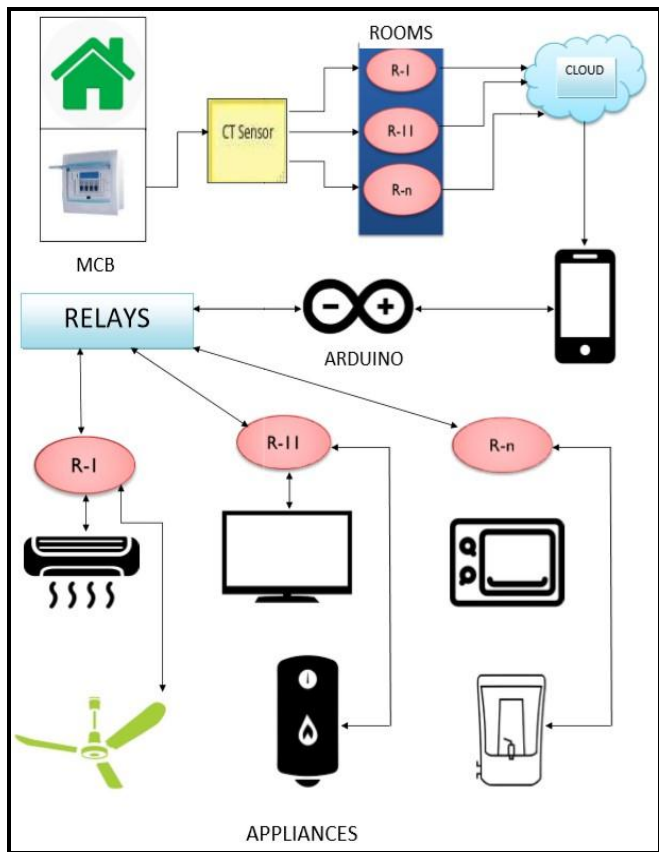

Fig -4: The Architecture of the proposed system

4. METHODOLOGY

For the proposed system we use a current sensor which works on the principle of magnetic induction. This sensor works like a clammer. We have connected this sensor to Arduino which enables reading of the serial data from the sensor which otherwise gives analog output. Whenever the sensor is clamped around the wire and if current flows through it the magnetic coil will sense the current flow from the wire. The serial data which has been collected on microcontroller will be uploaded to the cloud. We have used the Thing Speak to upload the data simultaneously. These values are then learned by the machine learning algorithm. The data which is trained is used to determine the functioning of each appliance. The statistics of electricity consumed is retrieved on the mobile from the cloud. The users can now know the electricity usage of each appliance on the mobile application.

The algorithm sets a threshold level for each appliance and if the electricity consumed by the appliance is not within the threshold limit it notifies the user regarding the same. The algorithm learns the usage pattern of high voltage appliance and it automatically powers on and off the device. This reduces human interaction and limits the electricity consumption. The users can on and off the appliances from the mobile application.

The connections of the hardware are as follows:

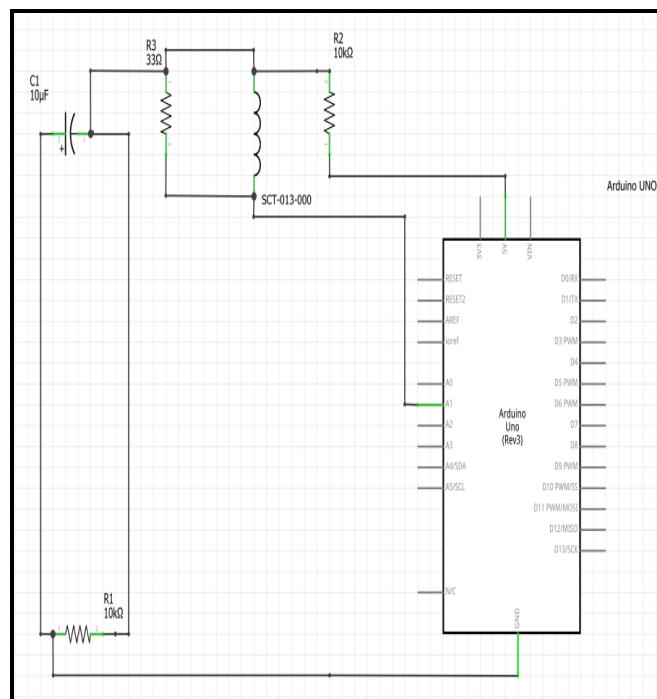

Fig -5: Circuit connections of current sensor

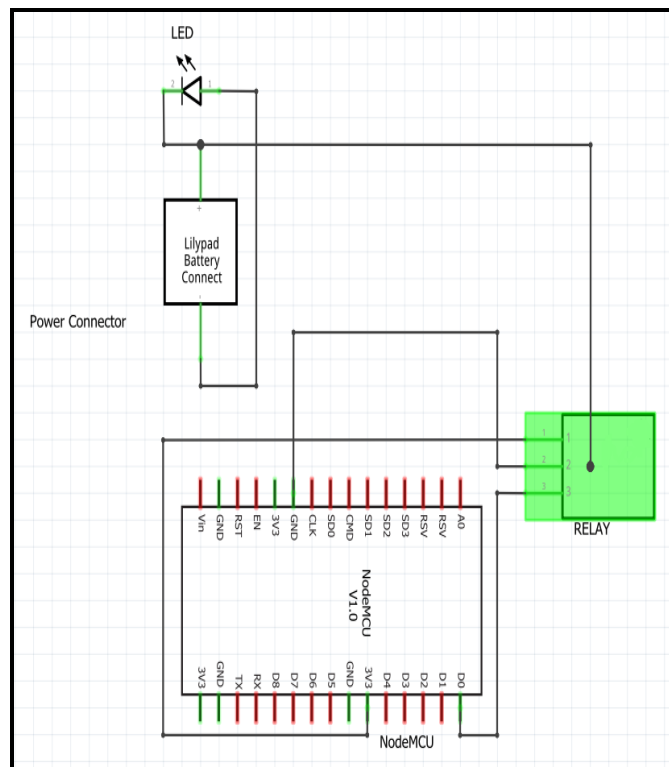

Fig -6: Circuit connections for powering off devices remotely

Following is the part of the algorithm which is used to study the data and train the algorithm for the same.

```
def train_test_regression(reg, X_train, X_test, y_train, y_test, pred_col):
    reg.fit(X_train, y_train)
    predict = reg.predict(X_test)
    predictions = pd.Series(predict.ravel(), index = y_test.index)
    predictions.rename(y_test.columns[0]+pred_col)
    predictions_frame = pd.DataFrame(predictions).join(y_test).dropna()

    return predictions_frame
```

Fig -7: Algorithm snippet

5. RESULTS

For the proposed system we have tested using a light bulb. We have collected its usage pattern for a period of days to determine the units consumed and to check the cost incurred for the corresponding usage. By using the proposed system, we can save up to 25% of electricity every month.



Fig -8: Application screenshots

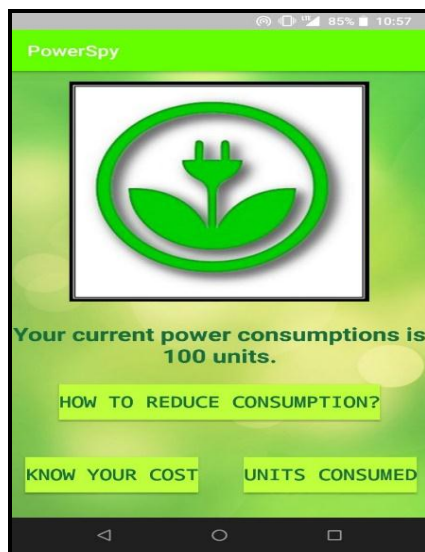

The above pictures are of the application. The application shows the units of electricity consumed. It shows the statistics in the form of the graph when the Units Consumed button is clicked. It shows the cost when the know your cost button is clicked.

6. CONCLUSION

In this paper, we have discussed how to monitor the electricity consumption of individual appliances in the household from one place at home without changing the wiring of the home. The knowledge of consumption of electricity at our home is now easy by the discussed proposed system, as now we can know it on our mobile and in a readable and understandable way. This system also enables us to monitor the appliances from a remote area.

The proposed system helps us save nearly 25% of the electricity monthly. If the temperature of the room is checked and then the devices are turned on and off, based on the surrounding temperature then the chances of saving the electricity cost increases by 40%.

Hence, for future work, we can add the temperature sensing devices to the proposed system.

The system has been functioning well with the 240V power supply at home and the devices are well calibrated to give the accurate readings. These devices are functioning well with the high voltage appliances.

REFERENCES

[1] <http://www.financialexpress.com/economy/electricity-consumption-in-india-power-demand-to-rise-7-cagr-in-5-year/716957/>

[2]http://www.mospi.nic.in/sites/default/files/publication_reports/Energy_Statistics_2017r.pdf.pdf

[3]https://www.eia.gov/energyexplained/index.cfm?page=coal_reserves

[4] <http://www.carboncounted.co.uk/when-will-fossil-fuels-run-out.html>

[5] <http://in.pcmag.com/consumer-electronics/102412/feature/how-to-measure-home-power-usage>

[6] <https://www.saveonenergy.com/energy-consumption/>

[7] <https://forum.mysensors.org/topic/1464/sct-013-030-current-monitor-sensor/5>

[8] http://www.mcielectronics.cl/website_MCI/static/documents/Datasheet_SCT013.pdf

[9] <https://www.generationrobots.com/media/JQC-3FF-v1.pdf>



Name: Dr. J. Sasi Banu
Professor of Computer Science and Engineering Department.
St. Martin's Engineering College

BIOGRAPHIES



Name: Jalpa Patel
B. tech Computer Science and Engineering
St. Martin's Engineering College



Name: K. Avinash Reddy
B. tech Computer Science and Engineering
St. Martin's Engineering College



Name: M. Kirti
B. tech Computer Science and Engineering
St. Martin's Engineering College



Name: Dr. D. B. K. Kamesh
Head of Department of Computer Science and Engineering
St. Martin's Engineering College