

# Biometric Based Rationing System

Prof. K.Y. Rajput<sup>1</sup>, Lekha Rane<sup>2</sup>, Siddhi Sawant<sup>3</sup>

<sup>1</sup>Associate Professor, department of Electronics and Telecommunication Engineering, Thadomal Shahani Engineering College, Mumbai University, India.

<sup>2</sup>Undergraduate Students department of Electronics and Telecommunication Engineering, Thadomal Shahani Engineering College, Mumbai University, India.

\*\*\*

**ABSTRACT** - This paper is based on biometric technology which aims at constructing an efficient, automated, user-and-environment friendly rationing system. The system presented here uses GSM module to send a ubiquitous SMS regarding the availability of goods to the enrolled customers. The system is put forth by interfacing a fingerprint scanner R 305 with Atmega 328P- PU along with a GSM and Bluetooth modules. After completion of the weighing process the database gets updated and the customer gets a list of the purchase via Bluetooth module. All the transactions will be finally updated in the database which will be transparent to all the users.

**Keywords** - Atmega 328 P-PU, Bluetooth, Fingerprint Scanner R305, GSM SIM 800L

## 1. INTRODUCTION

India's rationing system mainly emphasizes on providing a quality food service to the under-resource people to fulfill the minimum criteria of overall nourishment in the food intake. The government provides the rations in fair price shop at a low price to below poverty line people. But due to the malicious behavior of some fair price shop owners they indulge in malpractices. Ideally, for smooth functioning of the rationing system it is quintessential that the customers and government can access the information related to ration process and if found any glitch they may be able to lodge a complaint to the higher authorities or take the necessary action respectively. To mitigate some of the problems pertaining to the current system we have come with a prototype- 'Biometric Based Rationing System' such that it mitigates the level of corruption taking place in the rationing system and allows transparency in the system and the smooth flow of ration.

The features of this project are:

- Transparency in the distribution of goods.
- Customers are always updated about the availability of ration in the fair price shops.
- No illegal black marketing of ration in the open market.
- The government will have the control over the entire system.

## 2. OBJECTIVE

Biometric Based Rationing System will help to improvise the conditions of the under-resource people in India. This system will mitigate the corruption taking place at fair price shops as follows

- Transparency in entire system.
- Shopkeepers will be accountable for fair distribution of ration that has been provided to them.
- There won't be hoarding and black marketing of goods.
- Customers don't have to visit fair price shops for inquiring about the availability of ration in shop.

## 3. LITERATURE SURVEY

The existing structure of the PDS works in a Cooperative Federalist system in which both Centre and State shares the responsibility. The Central Government is responsible for buying food grains from farmers at MSP. The Central Government then allocates the grains to each state based on a pre-determined formula. The State Government is responsible for identifying the poor and eligible households in the states. The Centre transports the food grains to the Central depots (FCI) in each state. After that, the state government is responsible for delivering the food grains from the center depots to the ration shops. The Ration shops are the ultimate end points from where the food grains are sold to PDS beneficiaries. [1]

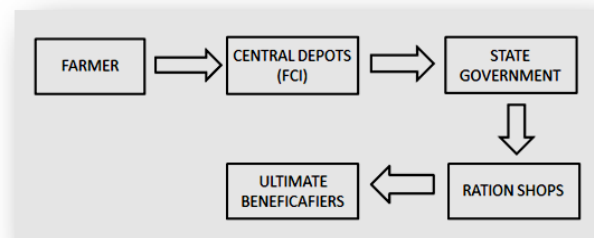

Fig 3.1 Flow of goods in PDS

The ultimate beneficiaries are divided into three categories depending upon the annual family income. For ease of separation beneficiaries from the four categories are provided with different color cards.

Types of cards:

- Yellow Ration Card: For families with annual income up to Rs. 15,000. 35kg grain per month.
- Orange Ration Card: Families with annual income of Rs. 15,001 to 1 lakh. 15kg of grain per month.
- White Ration Card: Families with annual income more than 1 lakh. Not entitled to food rations.[2]

**Fallouts of current system:**

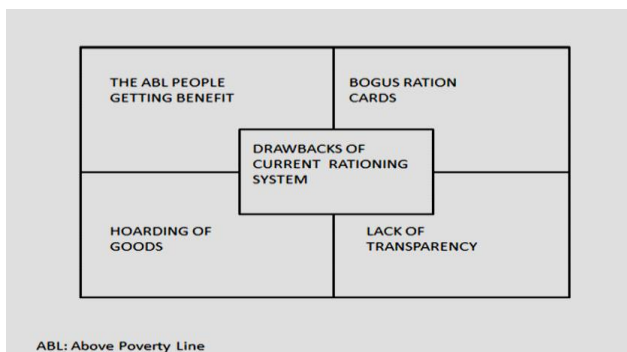

Fig. 3.2 Drawbacks of current system

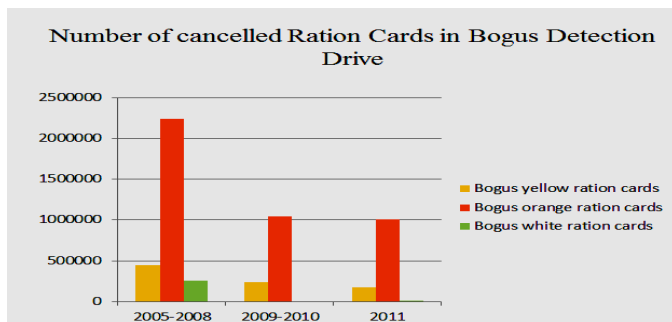

Fig. 3.3. Graph of bogus ration cards holders

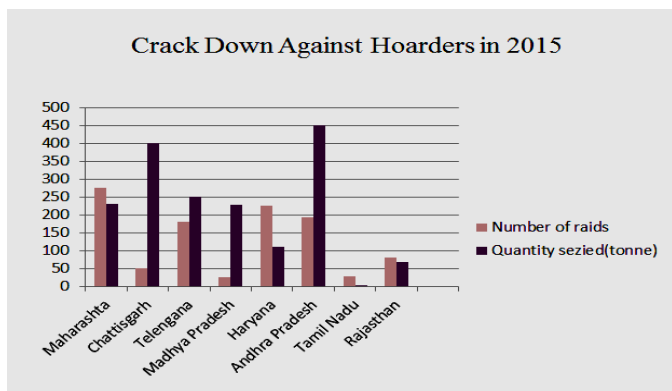

Fig.3.4 Graph of Crack Down Against Hoarders

**4. System Design and Implementation**

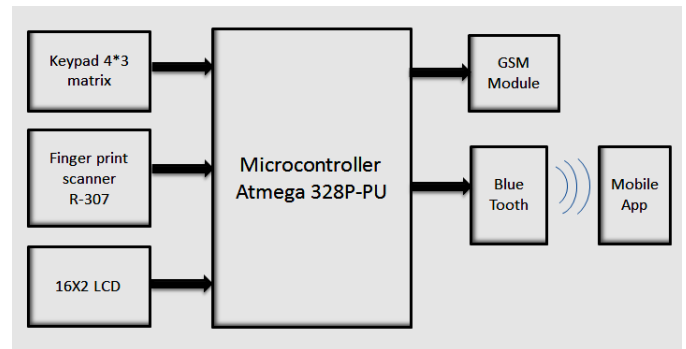

Fig. 4.1 Block diagram of proposed system

**Components**

**I. Microcontroller**

In this prototype we use a Atmega 328P-PU which is developed by Atmel. It is a very high performance microchip. Atmega 328P-PU is a 8-bit AVR RISC based microcontroller which mean they have pipe-lined processors in them which leads to faster execution. It has a 32KB ISP flash memory with read while write capabilities, 1024B EEPROM , 2KB SRAM, 23 general purpose I/O lines etc. As this prototype need real time control, fast processing, high end communication protocol, functions like ADC and large memory requirement, Atmega 328P-PU is the best suited processor for this prototype. Refer fig 4.2 [3]

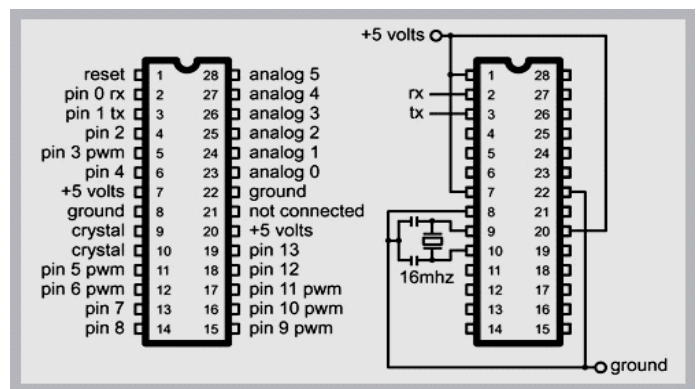

Fig.4.2 Pin Configuration and Standalone circuit diagram of ATmega 328 PPU

**II. LCD**

LCD is an abbreviation for Liquid Crystal Display. The prototype uses a 16x2 LCD to display various things such as validation of fingerprint, displaying the menu of available items in the fair price shops. In 16x2 LCD, 16 means the given LCD can display 16 characters per line and 2 means there will be 2 such lines that are used to display 16 characters per line. In this LCD each character is displayed in 5x7 pixel matrix. Inside a LCD there are two registers:

Data and Command. The Data register is used to store all the data that has to be displayed on the LCD. The Command register is used to store the command instructions that are provided to the LCD. Refer fig 4.3 [4]

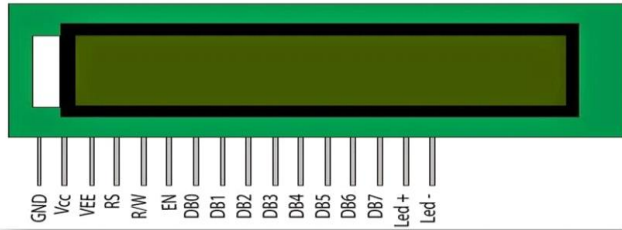

Fig 4.3 16x2 LCD

### III. Bluetooth Module

The Bluetooth module used here is a HC-05 module which is a basically master-slave module. This module has a default role of that of a slave where it cannot initiate a connection with another module, but it can accept connection from other master Bluetooth modules. Hence it is ideal for embedded systems project. It consists of 6 pins- Vcc, GND, TX, RX, Key and LED. Refer fig 4. 4 [5]

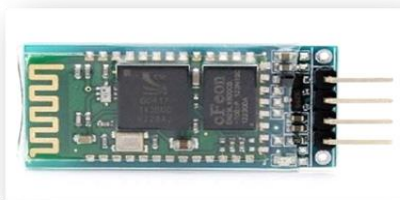

Fig. 4.4 HC-05 Bluetooth Module

### IV. 4x4 Keypad Matrix

In this proposed system a 4x4 keypad matrix is used. Here, 4 x 4 stands for 4 columns and 4 rows. There is a push button underneath each key where one end is connected to row and other to column. The user selects desired goods and as well as their desired quantity using keypad which acts as an input to the microcontroller. Refer fig 4. 5 [6]

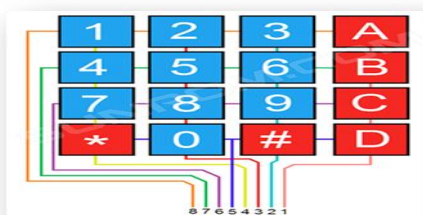

Fig 4.5 4x4 Keypad Matrix

### V. Fingerprint Scanner R-305

R 305 is an optical fingerprint scanner, it uses TTL UART interface for direct connections to a microcontroller UART. The fingerprint identification process has two steps that is

1. Enrolling Fingerprint: In this identification process, the new user has to register his fingerprint and a unique number is allocated to that fingerprint for an ease of search from the database.
2. Matching Fingerprint: R 305 uses 1:N mode for the purpose of matching a fingerprint. In the identification process the enrolled user needs to scan his fingerprint for the matching process. Refer fig 4. 6 [7]



Fig.4.6 R305 Fingerprint Scanner

### VI. GSM Module

The SIM 800L is generally used for a GSM/GPRS network and SMS message data remote transmission. It generally supports microcontrollers of voltage higher than 2.8V and as a result it is very suitable for proposed system which have used microcontroller. This module communicates with the microcontroller via the UART port. This module also has an inbuilt GPS technique called mobile positioning where it obtains the position via a mobile network and hence it can also be used as a tracker. Refer fig 4. 7 [8]



Fig.4.7 GSM Module

### 5. SYSTEM WORKING

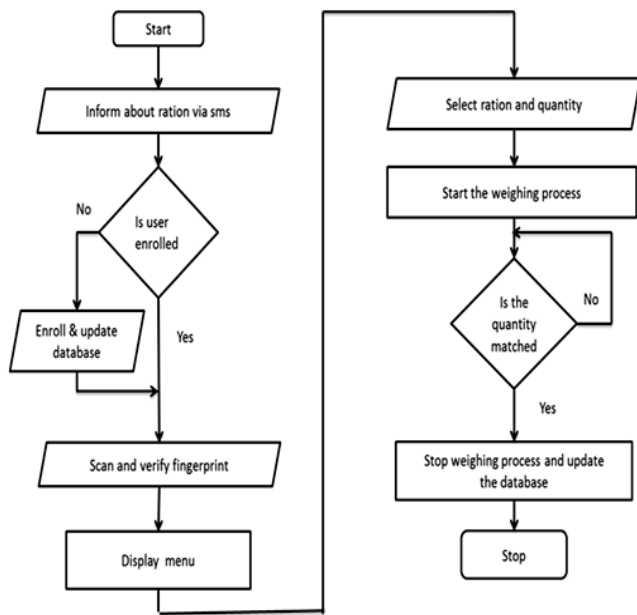

Fig. 5.1 Functional flow chart of the proposed system

In this system, if the customer is new and has not enrolled his/her fingerprint, then scanning and enrollment of the fingerprint will take place first and the database will be updated. Once the goods are delivered at a fair price shop all the customers will receive a SMS via the GSM module about the availability of ration in the shops. When the customers will go to the shop, their fingerprint will be scanned. Once it is verified that the customer is authentic, the menu will be displayed on the 16x2 LCD which lists the items that can be available for the purchase. The customer will then select the desired items and the quantity with the help of a 4x4 keypad matrix. Once this information is given at the input, the weighing process will start. A weighing scale will be interfaced to the microcontroller which will measure the quantity. If the quantity is less, then weighing process will be in process. After the weight of the quantity is matched with the entered value the weighing process stops. The database gets updated the user will be notified about their purchase and the amount of ration left in the fair price shop via a SMS send through Bluetooth module on their registered mobile number.

### 6. RESULTS AND ANALYSIS

The project is divided into 2 parts. A short description of each part is given below:

In this prototype, higher authorities and customers will have the information about the amount of goods transported and sold in a ration shop.

#### • Enrollment

When a new Biometric based ration shop is established in an area, people living in the vicinity of it need to get themselves enrolled.

The enrollment procedure is as follows:

- Procure the necessary documents to substantiate ones identify. Ones check and verified by the authority. The actual enrollment procedure starts. Start the system.
- LCD will display the message, "Place your Finger" press number 8 on the keypad. this button is used for enrollment procedure in the prototype, blue light will be displayed on the R-305 indicating that it is ready to take the finger impression. (Refer image 6.1.a)
- Place the finger on the scanner. Once scanned LCD displays, "Remove your finger. R-305 stores this print for comparison. (Refer image 6.1.b)
- The LCD then shows, "Place same finger " message on its screen. The user must place his/her same finger which was used for scanning for the first time. R-305 is ready to take second time impression by displaying the blue light. (Refer image 6.1.c)
- After taking both the samples, of finger prints, R-305 matches these samples. If the samples get matched then, LCD shows, "Print matched" message and further procedure can be conducted. If not, "Print not matched" message is displayed; the same process must be repeated from step number 1. (Refer image 6.1.d)
- Once samples are matched, a unique number has to be given to the finger print via a keypad matrix. Along with it, user has to give his/her mobile number for receiving the ration related messages. The finger print and the number get stored in the respective databases.

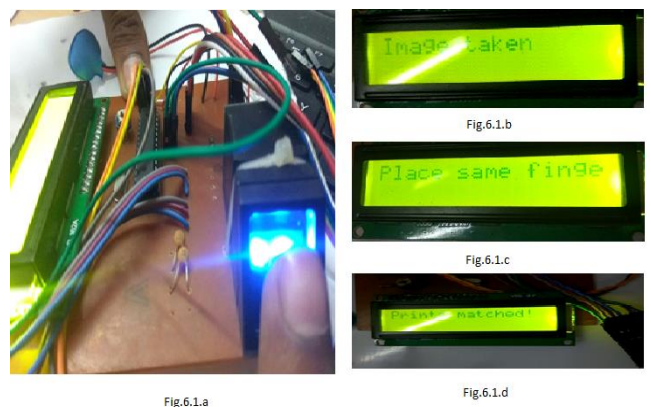

Fig.6.1 Steps for enrollment procedure

**• PURCHASE**

Once the goods are delivered to a particular fair price shop; users covered under it will receive a message on their registered mobile phones via GSM module. (Refer image 6.2.a)

The purchasing of commodities procedure is as follows:

- Switch ON the system. LCD will display, "Place your finger". Don't press any button on the keypad matrix this time. (Refer image 6.2.b)
- Blue light will be flashed by R-305 indicating it is ready. The user must place the same finger, used during enrollment procedure for scanning and verification.
- If the R-305 can find the match for the entered impression in its database, LCD will display, "Successful" and the registered mobile number of the user. If not then "Unsuccessful" and user has to start the procedure from step 1. (Refer image 6.2.c)



Fig6.2 Steps for purchasing of goods

- After successful authentication the LCD shows the menu as "1. Rice 2. Wheat 3. Jowar". Depending upon the needs the user selects desired commodities by pressing the corresponding key associated with the particular item through Keypad Matrix.
- Once the commodity is selected the user has to choose the amount of quantity required. The LCD will show the quantities as, "1. 5kg 2. 10kg 3. 15kg". Selection of the required quantity of goods is done by pressing the corresponding key associated with the desired quantity via keypad matrix.
- During the weighing process, the LCD displays, the registered number of the user and its unique finger print number. User can check whether the mobile number displayed is his/her or can request to be changed by noting down the unique number to the owner.

- After purchasing the commodities, user gets a message about his/her purchase on the registered phone numbers.
- At the same time, the database gets updated. Thus, making it easy for the users and higher authorities to check the activities pertaining to the dispensing of goods.



Fig.6.2 Steps for purchasing of goods

**7. CONCLUSIONS**

Ration forgery is one of the most difficult challenges faced by the public dispensing system. There may be chances where ration is not delivered or at subsidized prices to the beneficiaries and false records are noted down or there is probability that, shop owners selling the commodities in open market with extra profit etc. Therefore, the proposed system is more secure and transparent than the normal existing system. Entry of fallacious data in the ration database can be avoided with the use of biometric authentication. The shop owner's work is to weigh the commodities and give them to the respective recipients whereas updating and deducting the amount purchased is done automatically by the proposed system. Maintaining the database is also helpful for sending messages to the beneficiaries about the ration delivery. It is anticipated that the proposed project will create transparency in public distribution system as the work becomes automatic and it makes the system free from fabrications and other unsolicited activities.

**8. REFERENCES**

1. [https://en.wikipedia.org/wiki/Public\\_distribution\\_system](https://en.wikipedia.org/wiki/Public_distribution_system)
2. <https://www.aazad.com/should-know/types-of-ration-card-in-india.html>
3. <https://www.microchip.com/wwwproducts/en/ATmega328>

4. <https://techterms.com/definition/lcd>
5. <https://electrosome.com/hc-05-serial-bluetooth-module/>
6. <http://extremeelectronics.co.in/avr-tutorials/4x3-matrix-keypad-interface-avr-tutorial/>
7. <https://www.sunrom.com/p/finger-print-sensor-r305>
8. <https://www.elprocus.com/gsm-architecture-features-working/>

**BOOK REFERENCES:**

- Anil K. Jain, Fellow, IEEE, Arun Ross, Member, IEEE, and Salil Prabhakar, Member, IEEE, "An Introduction to Biometric Recognition", IEEE TRANSACTIONS ON CIRCUITS AND SYSTEMS FOR VIDEO TECHNOLOGY, VOL. 14
- Farahanum bt Masruni, "STUDENT'S ATTENDANCE SYSTEM USING FINGERPRINTTECHNOLOGY", I n Proceedings IEEE Computer Society Workshop on Biometrics (CVPR).
- D.Maltoni, D.Maio, andA.K.Jain, "Handbook of Fingerprint: Recognition", Springer Verlag, 2003
- 8051 microcontroller; ayala; microcontroller specification ; page 56Micro controller 8051;Maziddi ;max 232; page 115
- "ELECTRONICS TODAY MAGAZINE" January 2010, vol. 42 No.6 SMART CARDS TODAY; Page no.37.