

## THREE PHASE SUPPLY SYSTEM- AUTO SELECTION OF AVAILABLE PHASE & FAULT ANALYSIS

Anagha<sup>1</sup>, Utkarsh Singh<sup>2</sup>, Akansha Avinesh<sup>3</sup>, J.P.N. Verma<sup>4</sup>

<sup>1,2,3</sup>Under Graduate Student, Department of Electronics and Communication, SRM Institute of Science and Technology, Delhi-NCR, Modinagar, Ghaziabad, Uttar Pradesh, India

<sup>4</sup>Assistant Professor, Department of Electronics and Communication, SRM Institute of Science and Technology, Delhi-NCR, Modinagar, Ghaziabad, Uttar Pradesh, India.

\*\*\*

**Abstract:** Phase absence is a very common problem in developing countries like India. This paper is designed with an initiative to resolve two major issues associated with Three phase supply system, first being the phase absence, and the other being the presence of fault in the circuit. Our paper aims at delivering a system that provides uninterrupted power supply to the load even in the absence of any phase in a three phase supply system. In this system auto selection is achieved by using a set of relays interconnected in such a way that if one of the relay feeding to the load remains energized always. Along with that, the power supplying electric substations may deal with some failures due to presence of faults, which disrupts the entire working of system. These faults can even lead to substantial damage of the system. Thus, to avoid any disruption our paper delivers a system which deals with fault analysis, in a way that the output resets automatically after a brief interruption in the event of temporary fault while it remains in tripped condition in case of permanent fault and thereby sending a warning message to the number associated with the system using GSM modem.

### I. Introduction

Electricity is the lifeblood of modern world. It can be considered as one of the greatest inventions of our times. It is a wonder of the world that it is difficult to think of modern life without electricity. Electricity is very useful for us in our daily life. This serves man like slave, it makes our food, wash our clothes and clean our rooms, it converts night into day. Electricity is an important and essential component in the working of many equipments in any field, be it in household, hospitals or industries. All the machineries operate on three phase power supply.

But along with so many advantages, there is still instability in power in developing countries like India. Phase absence is one of the major drawbacks in three phase power supply system. The work done using machineries that run on three phases, often gets interrupted due to lack of availability of all the three phases. Most of the commercial operations are done using power supply, and manual changeover of the system would be time consuming. Thus an automatic system is required to provide uninterrupted power supply to the load. According to the system designed, the load gets the supply even if a single phase is available. The auto selection is achieved by using a set of relays interconnected in such a way that if one of the relay feeding to the load remains energized always.

The electric substations that supply power often deal with failures due to the presence of faults in the lines. These faults may be of any kind, LG (Line to Ground), LL (Line to Line), 3L (Three lines) in the supply systems and these faults in three phase supply system can affect the power system and can even lead to substantial damage of the system. To overcome this problem a system is built, which can sense these faults to avoid any disruption. The system that has been built deals with fault analysis, in a way that the output resets automatically after a brief interruption in the event of temporary fault while it remains in tripped condition in case of permanent fault. Considering the commercial usage, the system thereby sends a warning message to the numbers associated with the system using GSM modem in case of permanent fault.

## II. Block Diagram

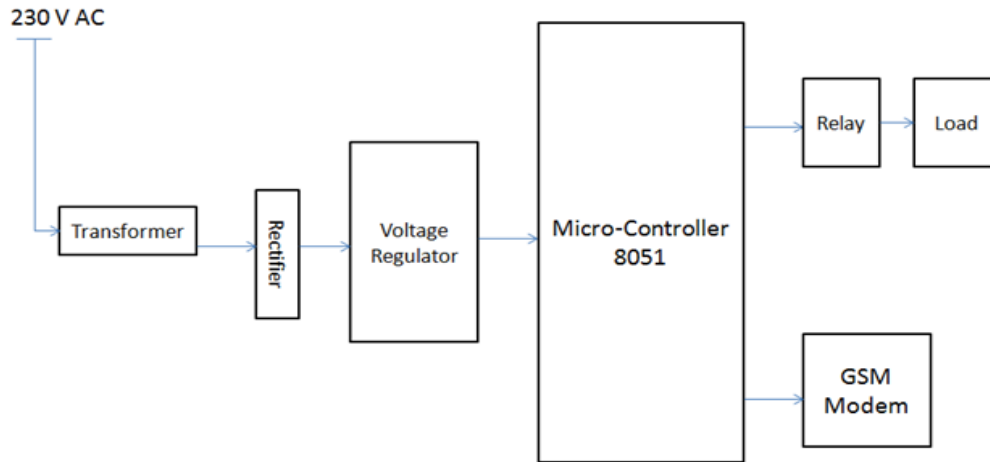

The above block diagram represents the basic layout of the entire system, of which this paper is all about. The main objective of the system is to provide uninterrupted power to critical loads in the event of missing phase. Along with that to sense the faults and automatically disconnect the supply to avoid large scale loss and inform the individual by sending a message in case of permanent fault. The entire process is carried out using transformers which depict the three phase supply system. The 220V is first step-down using transformer to 12V which is then rectified and using voltage regulator sent to the micro-controller such that the relay gets functioned. The auto selection is carried out using a set of relays which are connected to the load. The auto selection is made possible in a way that if one of the relay feeding to the load remains energized always. The fault analysis is done on the basis of the timer and a GSM modem is too connected so as to send a warning message in case of permanent fault in the system.

## III. CIRCUIT DIAGRAM

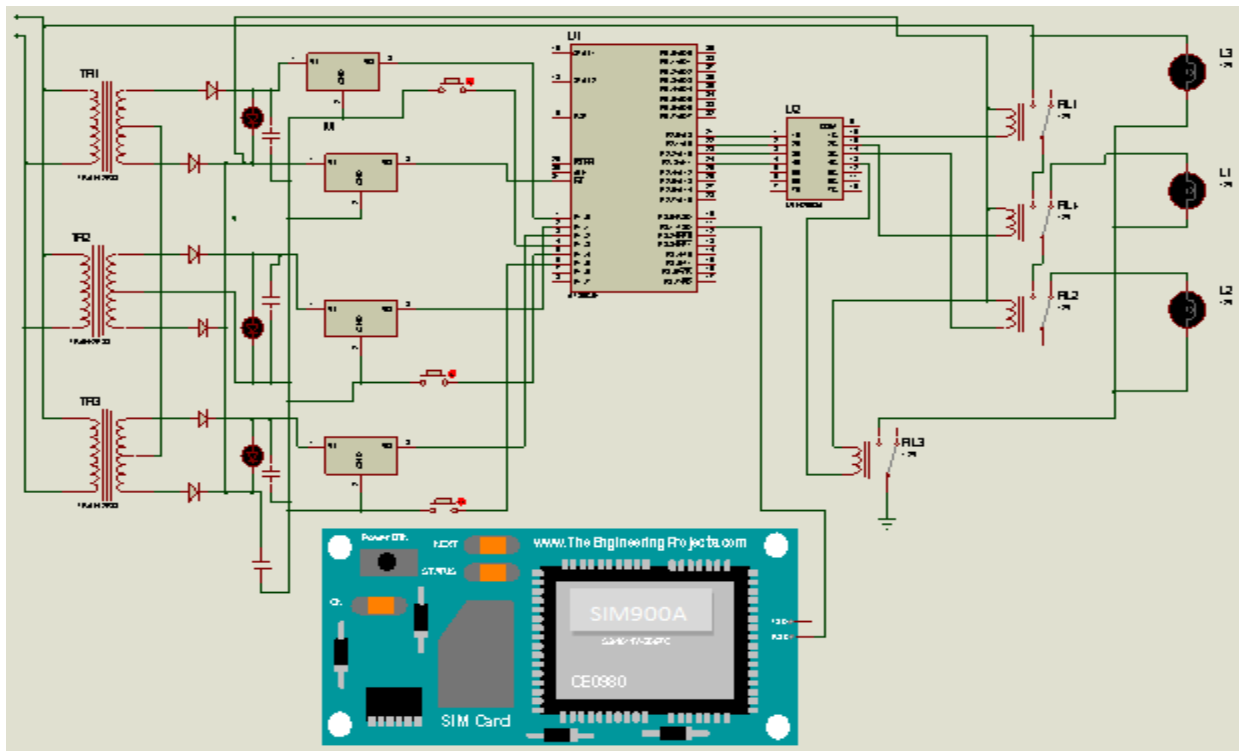

#### **IV. RESULT**

Phase absence being a very common problem in developing countries like India, our project aims at delivering a system which provides uninterrupted power to critical loads in the event of missing phase. The automatic selection of available phase was carried out using relays. Without the implementation of this system the work remained undone due to lack of availability of all the three phases. Our project deals with the aspect of fault analysis too.

#### **V. CONCLUSION**

The paper aims at delivering a system which is designed to provide uninterrupted supply, by automatic selection of available phase. Along with that, the system is equipped with a feature to detect any fault in the supply, and delivers output accordingly, i.e. trip during a temporary fault and reset in case of a permanent trip. The system is even equipped with GSM modem, so that in case of permanent fault, user or the official in the industries is informed through a message.

#### **VI. REFERENCES**

- Three Phase Faults Analysis of Power System By Tarang Thakur, Maharaja Agrasen Institute of Technology
- Smart Phase Change-over system with AT89C52 Microcontroller Mbaocha Christian Federal University of Technology Owerri Department of Electrical/Electronics Engineering
- Three Phase Fault Analysis with Auto Reset for Temporary Fault and Trip for Permanent Fault Sathish Bakanagari<sup>1</sup>, A. Mahesh Kumar<sup>2</sup>, M. Cheenya<sup>3</sup><sup>12</sup>(Asst.prof in EEE Department) <sup>3</sup>(Asst.Prof in ECE Department) Mahaveer Institute of Science and Technology, bandlaguda, Hyderabad.A.P.
- 3 PHASE FAULT DETECTION USING AUTO RECLOSING <sup>1</sup>Pankaj B. Sondarva, <sup>2</sup> Kishan P. Solanki, <sup>3</sup>Chandpa R. Mulu, <sup>4</sup>Harshad J. Bhakhar <sup>1</sup>UG Student, <sup>2</sup> UG Student, <sup>3</sup> UG Student, <sup>4</sup> Asst. Professor <sup>1, 2, 3, 4</sup> Department of Electrical Engineering, Dr. Subhash Technical Campus, Junagadh-362001
- AUTOMATIC PHASE SELECTOR USING MICRO-CONTROLLER AT89C51 Mr. Prasad Salunkhe<sup>1</sup>, Digvijay Raut<sup>2</sup>, Madhuri Patil<sup>3</sup>, Poonam salunkhe<sup>4</sup>, Mohd Yusuf<sup>5</sup> <sup>1,2,3,4</sup> Under Graduate Student , Dept. of Electrical Engineering, YSPM'YTC College, Maharashtra, (India) <sup>5</sup> Assistant Professor , Dept of Electrical Engineering, YSPM'YTC College, Maharashtra, (India)