

Temperature Analysis of Shell and Tube Heat Exchanger

Sumit S. Mukadam¹, Omkar V. Naik², Pratik S. Naik³, Priyanka P. Naik⁴, Amar S. Yekane⁵

^{1,2,3,4} U.G Students, Dept. of Mechanical Engineering, Finolex Academy of Management and Technology.

⁵ Assist. Professor, Dept. of Mechanical Engineering, Finolex Academy of Management and technology, Maharashtra, India

Abstract - This study has been undertaken to study the performance of the shell and tube heat exchanger. Shell and tube heat exchangers are one of the most commonly used type of heat exchangers in the industry for heat exchange purpose. This study shows the effect of various parameters such as pitch layout and baffle spacing on the heat exchanger performance. Standard analytical calculations are used to study the same. The study also shows the simulation work carried out using 'Solidworks 2016' software for the lab as well as industrial heat exchanger

Key Words: Shell and tube heat exchanger, flow simulation, pitch layout and baffle spacing

1. INTRODUCTION

A heat exchanger is a device used to transfer heat between a solid object and a fluid or between two or more fluids. The fluids may be separated by a solid wall to prevent mixing or they may be in direct contact. They are widely used in space heating, refrigeration, air conditioning, power stations, chemical plants, petrochemical plants, petroleum refineries, natural-gas processing, and sewage treatment. The classic example of a heat exchanger is found in an internal combustion engine in which a circulating fluid known as engine coolant flows through radiator coils and air flows past the coils, which cools the coolant and heats the incoming air.

A shell and tube heat exchanger is a class of heat exchanger designs. It is the most common type of heat exchanger in oil refineries and other large chemical processes, and is suited for higher-pressure applications. As its name implies, this type of heat exchanger consists of a shell (a large pressure vessel) with a bundle of tubes inside it. One fluid runs through the tubes, and another fluid flows over the tubes (through the shell) to transfer heat between the two fluids.

This study has taken into consideration a shell and tube heat exchanger installed in a particular pipe manufacturing company. There are various manufacturing processes which are performed in the industry. The compressors used in the VCM (Vinyl Chloride Monomer) manufacturing plant uses an oil for lubrication of bearing. Since the temperature of oil gets increased a shell and tube heat exchanger is used to lower the temperature of the oil using water. This cooled oil is again used for lubrication of compressor bearings. The heated water is further carried to the cooling towers.

The heat exchanger was installed at the time of establishment of the plant in 1994 and since then no modifications were made in the exchanger. So studying the heat exchanger and determining its overall heat transfer coefficient based on present working conditions is the aim of this project. A lot of research work has been carried out on the heat exchangers and its optimization with respect to thermal performance overview of such researches is explained in detailed in section 2 below.

2. LITERATURE REVIEW

Andre L.H. Costa and Eduardo M. Queiroz [1] presented a paper which deals with study about the design optimization of shell-and-tube heat exchangers. The formulated problem consists of the minimization of the thermal surface area for a certain service, involving discrete decision variables. Additional constraints represent geometrical features and velocity conditions which must be complied in order to reach a more realistic solution for the process task.

Abhishek Arya [2] carried out experimental work on fixed designed STHX and calculate the heat transfer coefficient and effectiveness. Validation is carried out which gives the result comparison with that of experimental result. Here flow parameters are not varied but size and number of tubes are varied and best efficient model is selected as Optimized value.

With the advent of computers, design procedures have become sophisticated even though the basic design remains the same. Because it is possible to specify an infinite number of different heat exchangers that would perform the given service, one has to identify the specific heat exchanger that would do it to certain constraints. These constraints can be based on allowable pressure drop considerations either on shell side or tube side or both and usually include that of minimizing cost. The flow of experimental as well as simulation work carried out on the heat exchanger is mentioned in detail in section III.

3. METHODOLOGY

With the advancement in simulation software's it is now possible to study the effect of various parameters on the performance of heat exchanger without changing the parameters in actual practice. This research work deals with such type of flow simulation of the heat exchanger and studying the effects. In order to validate the results obtained from flow simulation software, experiments have been

conducted using different mass flow rates of hot and cold fluids on the heat exchanger installed in FAMT (Finolex Academy of Management and Technology) institute. Further the results obtained from experimentation and software simulation are compared.

3.1 Details regarding FAMT lab heat exchanger

Figure 3.1 below shows the experimental setup of the shell and tube heat exchanger installed in the FAMT institutes laboratory.



Fig -3.1: Experimental setup of shell and tube heat exchanger

Material properties:-

Some of the material properties used in designing the model are as given below:

- Material: Steel (Mild)
- Density: 7870.00 kg/m³
- Specific heat: 472.0 J/ (kg*K)
- Conductivity type: Isotropic
- Thermal conductivity: 51.9000 W/ (m*K)

The table 3.1 below shows the specifications of the shell and tube heat exchanger installed in FAMT. It specifies the inner diameter, the thickness of the shell and the material used for manufacturing the shell. The inner and outer diameter for the tubes, the material used for construction and the number of tubes are mentioned below in the table. The length of the tubes and also the tube pitch layout is also shown below.

Table -3.1: Specifications of shell and tube heat exchanger

Shell specifications	Inner diameter	150mm
	Thickness	6mm
	Material	Mild steel
Tube specifications	Outer diameter	17mm
	Inner diameter	13mm
	Material	Mild steel
	Pitch	21.5mm

	Number of tubes	14
	Length	600mm
	Other details	
	Baffles	2 nos.
	Baffle spacing	200 mm
	No of pass	1:2 pass

Experimental Readings of Shell and Tube Heat Exchanger installed in the institute’s lab are given in table 3.2. Table below shows the variation in the temp of hot and cold fluids with the change in mass flow rates.

Table -3.2: Experimental readings

Sr.no	Mass flow rate(LPM)		Temperature (deg. c)			
	m _h	m _c	T _{h1}	T _{h2}	T _{c1}	T _{c2}
1	1.5	3	66	47	26	35
2	1.8	2.6	57	42	27	35
3	2.6	1.8	47	40	27	36

3.2 Details regarding industry’s heat exchanger

The different parameters of shell and tube heat exchanger installed in industry are shown with the help of tables. Table 3.3 gives a detailed idea regarding the temperatures and pressure under which the heat exchanger is presently working.

Table -3.3: Temperature Specifications

Sr. No.	Parameter	Shell side inlet	Shell side outlet	Tube side inlet	Tube side outlet
1	Fluid	Oil		Cold Water	
2	Operating Temperature	71	45	32	38

Table 3.4 below gives the specifications of shell and tube of industrial heat exchanger as given above previously for institute’s heat exchanger

Table -3.4: Specifications of industrial heat exchangers

Shell specifications	Inner diameter	219 mm
	Thickness	7.79 mm
	Material	Carbon steel (IS-3589)
Tube specifications	Outer diameter	19.05 mm
	Inner diameter	16.41 mm
	Material	Copper (IS-226)
	Pitch	23.08 mm
	Number of tubes	68

	Length	2690 mm
Other details	Baffles	45 nos
	Baffle spacing	55 mm
	No of pass	1:4 pass
	Pitch Type	Triangular

3.3 CAD Models

The CAD models for the heat exchangers installed in the institute as well as the one in industry are shown in this sub section 3.3. CAD model of Shell and Tube heat exchanger installed in the institute’s laboratory is shown in figure 3.2 below. It gives an idea about baffles, tubes, pitch layout and other similar factors.

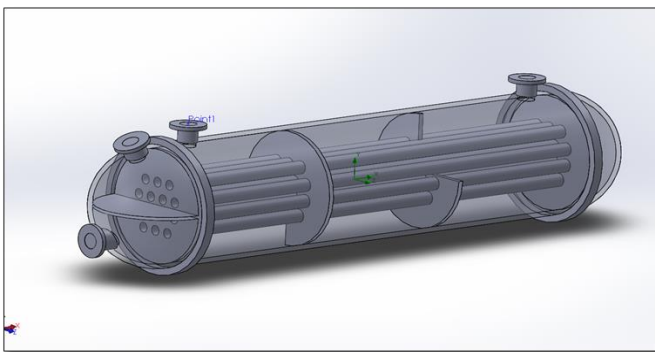

Fig -3.2: CAD Model (Institute’s Laboratory)

Fig. 3.3 below shows the CAD model of the industrial shell and tube heat exchanger. It gives an idea about the number of baffles spacing between them and the inlet and outlet of the exchanger.

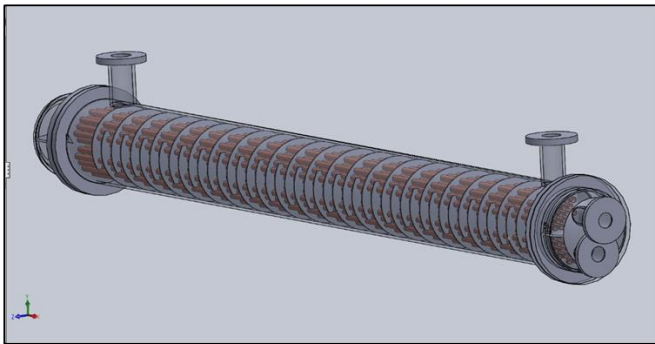

Fig -3.3: CAD Model (Industrial Heat Exchanger)

3.4 Analytical Calculations

This sub-section 3.4 shows the calculations for overall heat transfer coefficient using standard analytical equations. The kern method is applied for thermal design of the heat exchanger. Considering existing conditions that is with triangular pitch and baffle spacing as 55mm.

(Step 1):- Calculating the heat load

For hot fluid,

$$Q_h = m_h * C_{p_h} * (T_1 - T_2)$$

Where, m_h = mass flow rate of hot fluid

$$C_{p_h} = \text{Specific heat of hot fluid}$$

For cold fluid,

$$Q_c = m_c * C_{p_c} * (t_2 - t_1)$$

Where, m_c = mass flow rate of cold fluid

Average heat load,

$$Q_{avg} = \frac{Q_h + Q_c}{2}$$

(Step 2):- Logarithmic Mean Temperature Difference

Since it is a multipass heat exchanger, first one has to calculate LMTD for counter flow heat exchanger and then using correction factor exact LMTD for multipass heat exchanger can be found.

$$LMTD = \frac{(T_1 - t_2) - (T_2 - t_1)}{\ln\left(\frac{T_1 - t_2}{T_2 - t_1}\right)}$$

R and S are considered as dimensionless temperature ratios

$$R = \frac{T_1 - T_2}{t_2 - t_1}$$

$$S = \frac{t_2 - t_1}{T_1 - t_1}$$

The log mean temperature correction factor (F_t) can be given as,

$$F_t = \left[\frac{\sqrt{R^2 + 1} * \ln\left(\frac{1-S}{1-R*S}\right) * \left[(R-1) * \ln\left(\frac{2-5*(R+1-\sqrt{R^2+1})}{2-5*(R+1+\sqrt{R^2+1})}\right) \right]^{-1}}{R-1} \right]$$

Corrected mean temperature difference,

$$\Delta T_m = F_t * LMTD$$

(Step 3):- Assumption for overall heat transfer coefficient (U)

$$\text{Specific gravity} = \frac{\text{density of oil}}{\text{density of water}}$$

API gravity of oil can be given as,

$$\text{API gravity} = \left(\frac{141.5}{S.G_{oil}} \right) - 131.5$$

Oils having API gravity greater than 20 are called as light duty oils whereas oils having API gravity less than 20 are called as heavy duty oils. In this case since the API gravity of oil is 27.48, it is considered to be light duty oil.

For light duty oil and water combination in shell and tube heat exchanger the overall heat transfer coefficient (U) is assumed in the range of 350 – 900 W/m²k.

Assuming, $U_{o,assum} = 600 \text{ W/m}^2\text{K}$

(Step 4):- Calculating number of tubes and heat transfer area

According to research papers two important factors considered while calculating number of tubes are CTP and CL.

Where, CTP = Tube count constant (for 4 pass) = 0.85

CL = Tube layout constant = $\sin(60) = 0.866$

$$\text{Number of tubes, } N_t = \left(\frac{\pi}{4}\right) * \left(\frac{CTP}{CL}\right) * \left(\frac{D_s^2}{P_t^2}\right)$$

$N_t = 68$ (approx. according to the specifications given)

$$\text{Heat transfer area, } A = \pi * d_o * N_t * L$$

(Step 5):- Tube side and shell side heat transfer coefficient

(I) Tube side calculations:-

Reynolds number,

$$Re = \frac{4 * m_w * N_p}{\pi * d_i * \mu * N_t}$$

Where, m_w = mass flow rate of water

N_p = Number of tube passes

N_t = Number of tubes

d_i = Tube inside diameter

Prandtl number,

$$Pr = \frac{C_p * \mu}{K_f}$$

Tube flow velocity,

$$u = \frac{Re * \mu}{d_i * \rho}$$

Tube side heat transfer coefficient can be given as,

$$j_h = \frac{h_i * d_i}{k} * \left(\frac{\mu * C}{K}\right)^{-\frac{1}{4}} * \left(\frac{\mu}{\mu_w}\right)^{-0.14}$$

j_h for tube side fluid is selected according to the corresponding value of Re

$$\left(\frac{\mu}{\mu_w}\right) = 1,$$

Where μ = viscosity of tube side fluid

μ_w = Viscosity of tube side fluid at wall temperature

(II) Shell side calculations

Equivalent diameter for triangular pitch for shell side,

$$D_e = \frac{4 * (0.435 * P_t^2 - 0.125 * \pi * d_o^2)}{\pi * d_o}$$

Where, P_t = pitch for triangular pattern
 d_o = outside diameter

$$\text{Shell side cross flow area, } a_s = \frac{C * B * D_s}{P_t}$$

Where,

C = tube clearance = $P_t - D_o$

B = Baffle spacing = $0.5 * D_s$

Shell side mass velocity,

$$G_s = \left(\frac{m_s}{a_s}\right)$$

Reynolds number,

$$Re = \frac{D_e * G_s}{\mu_g}$$

Shell side heat transfer coefficient can be given as

$$j_h = \frac{h_o * D_e}{k} * \left(\frac{\mu * C}{K}\right)^{-\frac{1}{4}} * \left(\frac{\mu}{\mu_w}\right)^{-0.14}$$

j_h for shell side fluid is selected according to the corresponding value of Re

(Step 6):- Overall heat transfer coefficient

Overall heat transfer coefficient can be given as,

$U_o =$

$$\left[\left(\frac{1}{h_o}\right) + R_{fo} + \left(\frac{r_o}{K}\right) * \ln\left(\frac{r_o}{r_i}\right) + \left(\frac{r_o}{r_i}\right) * R_{fi} + \left(\frac{r_o}{r_i}\right) * \left(\frac{1}{h_i}\right) \right]^{-1}$$

Thermal conductivity for copper material, $K = 400 \text{ W/m}^2\text{K}$

$$\text{Now, } \frac{U_{o,assum} - U_{o,calc}}{U_{o,assum}} * 100 = \frac{600 - 520}{600} * 100$$

$$= 13.33\% < 30\%$$

Therefore, the calculated overall heat transfer coefficient is well within the design criteria. If the above condition satisfies the calculated overall heat transfer coefficient is well within the design criteria.

For change in baffle spacing, the change occurs only in shell side cross flow area. One should consider the maximum pressure drop constraint while changing the spacing between the baffles.

For change in pitch layout from triangular pitch to square pitch, the tube layout constant changes accordingly. Further the number of tubes, heat transfer area, Reynolds number, tube flow velocity and the tube side heat transfer coefficient also changes. Whereas the shell side heat transfer coefficient changes due to change in hydraulic diameter.

The hydraulic diameter for square pitch can be given as,

$$D_e = \frac{4 * (P * t^2 - 0.25 * \pi * d_o^2)}{\pi * d_o}$$

4. RESULTS

This section shows the results obtained from flow simulation of the CAD model of the FAMT institute’s heat exchanger. These results are further validated with those obtained from experimentation. The results obtained from analytical calculations are also shown below.

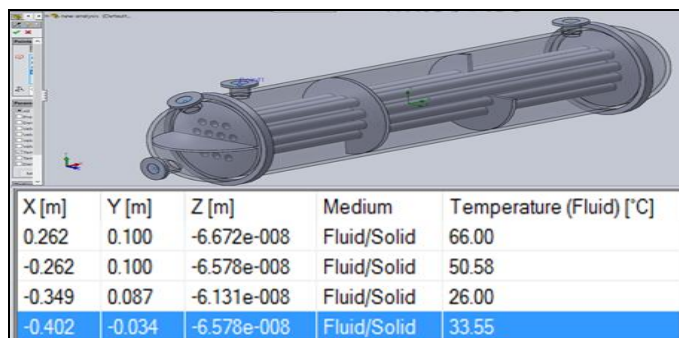

Fig -4.1: Simulation Temperature Results (FAMT lab heat exchanger)

Fig. 4.1 shows the temperature results obtained after flow simulation of the CAD model using ‘Solidworks flow simulation 2016 software’. The chart shown in fig 4.1 shows the validation of the results obtained from flow simulation with those obtained by experimentation (Lab heat exchanger). The values shown in the figure are approx. closer to those obtained by experiments.

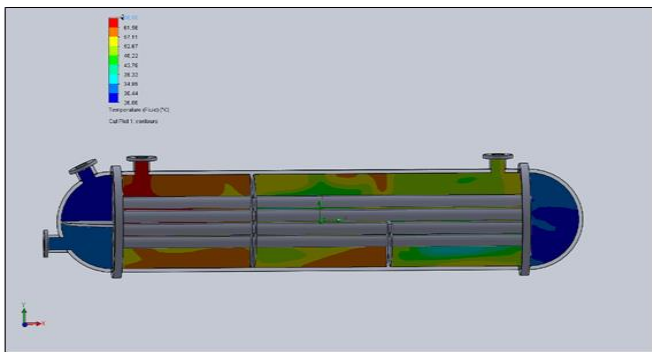

Fig -4.2: Temperature Simulation

Fig 4.2 shows the temperature simulation that is how the temperature changes throughout the length of heat exchangers. Further Fig 4.3 shows the temperature results obtained from simulation of the CAD model of industrial heat exchanger. The chart shown in fig 4.3 shows the validation of the results obtained from flow simulation with those obtained by experimentation (Industrial heat exchanger).

X [m]	Y [m]	Z [m]	Medium	Temperature (Fluid) [°C]
-0.342	1.869	2.342	Fluid/Solid	51.18
2.416	1.539	2.392	Fluid/Solid	32.00
2.465	1.654	2.392	Fluid/Solid	35.78
2.117	1.869	2.342	Fluid/Solid	71.00

Fig -4.3: Simulation Temperature Results (industrial heat exchanger)

Fig 4.4 shows the temperature simulation that is how the temperature changes throughout the length of the heat exchanger.

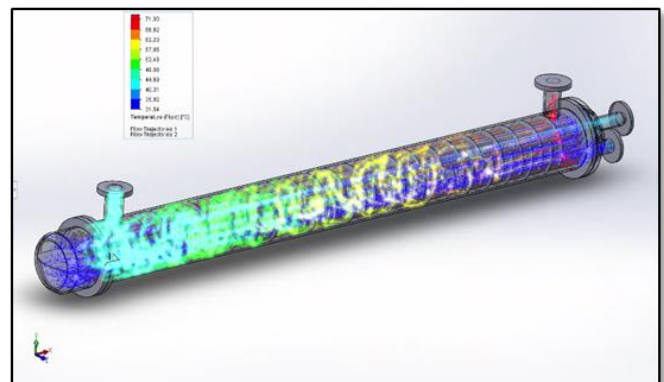

Fig -4.4: Temperature Simulation

Results obtained from standard analytical calculations changing different parameters of the heat exchanger such as baffle spacing and tube pitch layout and their effect on overall heat transfer coefficient are shown in table 4.1

Table -4.1: Results

Sr. No.	Parameter	Value of U _o	Effect
1.	(Case I) Existing conditions, (Baffle spacing 55mm with triangular pitch layout)	520 W/m ² K	-
2.	(Case II) Baffle spacing 55mm with square pitch layout	500 W/m ² K	U _o decreased
3.	(Case III) Baffle spacing changed to 51mm with triangular pitch layout	554.32 W/m ² K	U _o increased
4.	(Case IV) Baffle spacing changed to 51 mm with square pitch layout	526.60 W/m ² K	U _o increased

4. CONCLUSIONS

From the results of flow simulation of the heat exchanger it can be concluded that the simulation gives results close to those obtained from experimentation. Further it can be concluded that the overall heat transfer coefficient gets affected due to various parameters such as baffle spacing and tube pitch layout. It can be found that using square pitch overall heat transfer coefficient decreases, whereas it increases with decrease in the baffle spacing.

According to the experimental procedure the temperature difference obtained in case of lab heat exchanger for hot fluid is $(66-47=19^{\circ}\text{C})$ and for cold fluid is $(35-26=9^{\circ}\text{C})$. Further the results obtained from simulation showed that the temperature difference for hot fluid is $(66-50.58=15.42^{\circ}\text{C})$ and for cold fluid is $(35.55-26=9.55^{\circ}\text{C})$. Comparing the results obtained from experimental procedure and simulation approach it can be said that the values are close to each other.

Similarly according to the experimental procedure carried out for industrial heat exchanger, the temperature difference for hot fluid is $(71-45=26^{\circ}\text{C})$ and for cold fluid is $(38-32=6^{\circ}\text{C})$. Further the results obtained from flow simulation showed that the temperature difference for hot fluid is $(71-51.8= 19.2^{\circ}\text{C})$ and for cold fluid is $(35.78-32=3.78^{\circ}\text{C})$.

REFERENCES

- [1] Andre L.H. Costa and Eduardo M. Queiroz, "Design optimization of shell and tube heat exchangers", 19th Nov 2007.
- [2] Abhishek Arya, "Optimization of shell and tube heat exchanger", Vol. 1, Issue 2, 5th Nov 2015.
- [3] D. Q. Kern, "Process Heat Transfer", 1965.
- [4] R. K. Rajput, "Heat and mass transfer", Fifth edition, 2011.
- [5] Vijay Gupta, "Elements of heat and mass transfer", First Edition, 2012.