

Security System using Arduino Microcontroller

Suman Thakur¹, Mr. Manish Verma², Mr. Lumesh Sahu³

¹Department of Electronics and Communication Kalinga University, Raipur, C.G

²Assistant Professor, Department of Electronics and Communication, Kalinga University, Raipur, C.G

³Assistant Professor, Department of Electrical Engineering, Kalinga University, Raipur, C.G

Abstract— Security has been becoming an important issue everywhere. Every person wants his home, industry; bank etc to be secured Home security is becoming necessary. Now days as the possibilities of intrusion are increasing day by day. Hardware of this system has been designed using microcontroller AT Mega 328, PIR (Passive Infra Red) motion sensor as the primary sensor for motion detection, camera for capturing images, GSM module for sending and receiving SMS and buzzer for alarm. For software this system using Arduino IDE for Arduino and Putty for testing connection programming in GSM module. This Home Security System can monitor home area that surrounding by PIR sensor and sending SMS, save images capture by camera, and make people panic by turn on the buzzer when trespassing surrounding area that detected by PIR sensor. The Modular Home Security System has been tested and succeed detect human movement.

Keywords: Microcontroller, Arduino, GSM, PIR Sensor, SIM 800, Quad Band.

I. Introduction

In day to day life home security is very important factor. It is trending issue in 21st century. Security is primary concern everywhere and for everyone. every person wants his home, industry, banks etc to be secured. This project describes a security system that can monitor an industry & home. This is a useful and simple security system. here, our application uses arduino as its controller to detect the presence of human and immediately buzzer alerts is given to intimate others. This paper is based on embedded system where microcontroller is use for home security. This system can operate using cellular phone with the help of GSM technology. This system is to implement microcontroller based controlled module that receives it's instruction and command for cellular phone over the GSM network. This microcontroller then will carry out the issued Commands and then communicate the status of a given applicants or device back to the cellular phones.

Securing a home is an indispensable task because of the burglary incidents. The conventional design of home security systems typically monitors only the property and lacks physical control aspects of the house itself. In today's context, it is common to leave the house unattended as people are busy catching up with their tight daily schedule. Therefore, most people have chosen the home security system as the most reliable way to protect their home. All

the body generates some heat energy in the form of infrared which is invisible to human eyes. But, it can be detected by electronic sensor. PIR sensors are widely applied in wireless residential security systems, home alarms systems and many more security circuits as motion detector sensors. A typical PIR sensor detects the Infrared Red (IR) waves from human body and so it is also known as 'human sensor'. This system is very simple. And the working of this system is very simple as well. In this system PIR sensor used for sensing and then microcontroller is used for controlling purpose and a GSM module which is used for SMS and calling purpose. When anybody comes in range of PIR sensor, then sensor sends a logic signal to microcontroller and take control and perform a given task.

II. MODEL DESCRIPTION AND ANALYSIS

A). ARDUINO UNO MICROCONTROLLER:-

The Arduino Uno is a microcontroller board based on the ATmega328 (datasheet). It has 14 digital input/output pins (of which 6 can be used as PWM outputs), 6 analog inputs, a 16 MHz crystal oscillator, a USB connection, a power jack, an ICSP header, and a reset button. It contains everything needed to support the microcontroller; simply connect it to a computer with a USB cable or power it with a AC-to- DC adapter or battery to get started. UNO Microcontroller is programmed using an Arduino Integrated Environment or rather Arduino Software [IDE]. This IDE helps in writing an instruction code for the Arduino. Arduino can interact with buttons, LEDs, motors, speakers, GPS units, cameras, the internet, and even your smart-phone or your TV!

B). PIR SENSOR:-

Passive Infra-Red or PIR Sensor is a pyroelectric device that detects motion. Hence, it is also called as motion detection sensor. it detects motion by sensing the changes in infrared levels emitted by nearby objects. PIR sensors are used to detect living being movement. PIR is a Passive Infrared sensor, which detect infrared rays. All living being with a temperature above absolute zero emits heat energy in the form of radiation.

These radiations are infrared ray. Human eye cannot see these rays because these rays are radiated at infrared wavelength. When any living being comes in range of PIR sensor, it detects heat of that living being and generates an output. PIR sensor module does not send any rays for

detection; its only detects heat (Infrared). Passive elements are those elements that don't generate their own voltages or energy. They just only measures things. So we can say that this sensor is a passive infrared sensor and it doesn't generate anything by itself. It is only capable to measure the radiations emitted by other objects around it. It measures those radiations and do some desired calculations. PIR sensor has total 3 pins: 1.Pin#1 is of supply pin and it is used to connect +5 DC voltages 2.Pin#2 is of output pin and this pin is used to collect the output signal which is collected by PIR sensor. Pin#3 is marked as GND pin. This pin is used to provide 3. ground to internal circuit of PIR sensor.

C).BUZZER:-

A buzzer or beeper is an audio signaling device, which may be mechanical, electromechanical, or piezoelectric. Typical uses of buzzers and beepers include alarm devices, timers, and confirmation of user input such as a mouse click or keystroke Such buzzers are used in gas alarms, burglar alarms, etc. In this detector the buzzer gives the output sound when the LPG gas is detected by the sensor. So the buzzer serves as the audio output of the detector.

D).LCD DISPLAY:-

An LCD is an electronic display module which uses liquid crystal to produce a visible image. The 16x2 LCD display is a very basic module commonly used in DIYs and circuits. The 16x2 translates o a display 16 characters per line in 2 such lines. In this LCD each character is displayed in a 5x7 pixel matrix.

E). GSM MODULE:-

This GSM Modem can accept any GSM network operator SIM card and act just like a mobile phone with its own unique phone number. Advantage of using this modem will be that you can use its RS232 port to communicate and develop embedded applications. The MODEM needs AT commands, for interacting with processor or controller, which are communicated through serial communication. These commands are sent by the controller/processor. The MODEM sends back a result after it receives a command It requires supply voltage in the range 3.4 ~ 4.4V

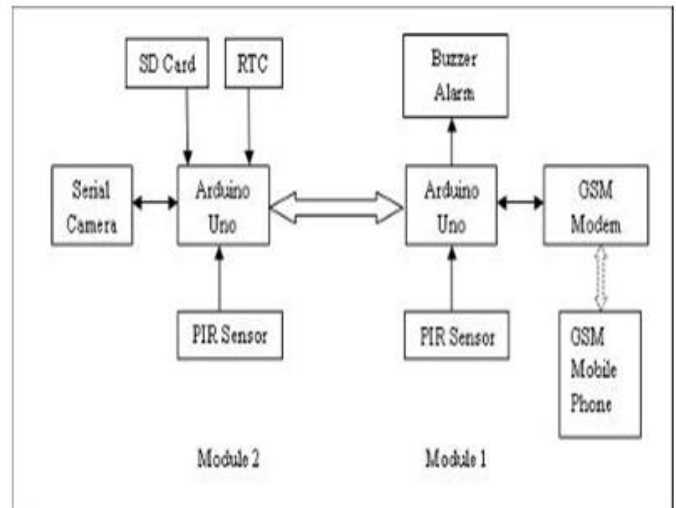

Fig1. Block diagram for gas detection

III. METHODOLOGY

In this system PIR sensor used for sensing and then microcontroller used for controlling and then a GSM module which is used for calling purpose. When anybody comes in range of PIR sensor, then sensor sends a logic signal to microcontroller, then it will necessary action to take control and perform a given task. Here a calling and SMS task is given to microcontroller using GSM. Security Alarm Systems are very important in present day society, where crime is increasing. With the technological advancements we have achieved in the recent years, a homeowner doesn't have to worry about home security while getting off his/her home. Modern home security systems provide enough security from burglars; fire, smoke, and etc.They also provide immediate notification to the homeowner.

The aim of this project is to implement a simple and affordable, but efficient home security alarm system. The project is designed for detecting intruders and informing the owner.PIR sensor detects motion by sensing the difference in infrared or radiant heat levels emitted by surrounding objects. The output of the PIR sensor goes high when it detects any motion. The range of a typical PIR sensor is around 6 meters or about 30 feet. For proper operation of PIR sensor, it requires a warm up time of 20 to 60 seconds. This is required because, the PIR sensor has settling time during which it calibrates its sensor according to the environment and stabilizes the infrared detector. During this time, there should be very little to no motion in front of the sensor. If the sensor is not given enough calibrating time, the output of PIR sensor may not be reliable.When the PIR sensor detects any motion, the output of the sensor is high.This is detected by the Arduino.

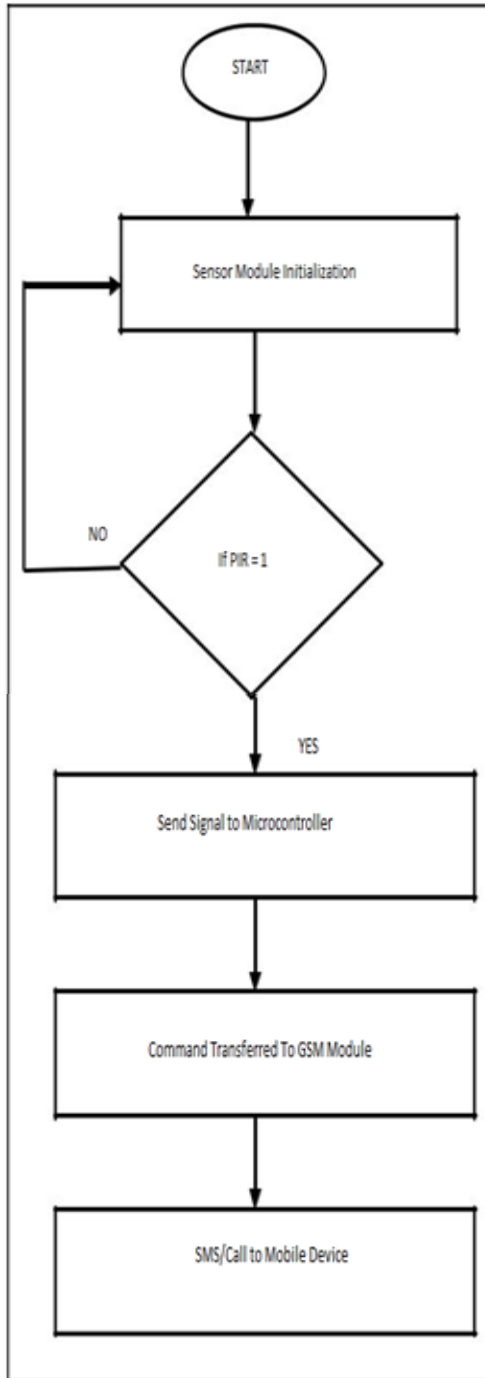

Fig2. Flowchart of the working

IV. FUTURE SCOPE

Android app will also develop for easily use. In Android app there will be direct buttons for on or off the system or to receive the OTP. For more security purpose camera module can also be implemented on the system. If any person attempt to enter in home with more than three time wrong password then at that time camera module will be activated. And camera module will capture the image of person who trying to attack on system. Future Enhancements Future suggestions of this project are very great considering the

amount of time and resources it saves. This system can be used as reference or as a base for realizing a scheme to be implemented in other project of greater including the audio-visual camera by sending the captured images to an email instantly. The project itself can be modified to achieve a complete home automation system which will then create a motion system which will then create a platform for user to interface between himself and his household. In this system GSM shield is a very important part for communication between mobile phone and microcontroller GSM Shield required the SIM card, due to range fluctuation or busy network sometimes GSM shield will not work properly.

V. CONCLUSION

In this paper, a novel architecture for flexible home security and monitoring system using Arduino microcontroller is proposed and implemented. The important of home security measures are elaborated using easily available programmable sensors like the PIR sensor, LM35 (Temperature sensor), by implementing this type of system we can secure entry point of our. Home as well as for more security we can use various sensors. This security home feature become draw much attention in the future. People getting more concerned to protect their house from unauthorized people. This system can monitor a house by use of sensors that integrated with a microcontroller and a GSM unit. SMS use to alert users via mobile phone when a possible intrusion occur. Today almost everyone using mobile phone so by use this system user will not have to carry additional device to monitor their house.

References:

- 1) Priya H. Pande¹, Nileshwari N. Solanke¹, Sudhir G. Panpatte¹ "Security System using Arduino Microcontroller" Vol. 4, Special Issue 3, January 2017.
- 2) 1Rajani U S, 2Kadar A.A "GSM Based Home Security System Using PIR Sensor" Vol. 8, Issue 2, April - June 2017
- 3) Sadeque Reza Khan, Ahmed Al Mansur, AlvieKabir, Shahid Jaman, Nahian Chowdhury, "Design and Implementation of Low Cost Home Security System Using GSM network", International Journal of Scientific and Engineering Research, Vol. 3, Issue 3, 2012.
- 4) Mahendran.N, Geo Joe Mathai, Veenesh.M.U, "Multiple sensor feeding supported, building automation system using arduino platform", With Exposure of 802.15.4 Functionalities, International Journal of Engineering Trends and Technology, Vol. 4, Issue 2, 2013.

- 5) Raj Sharma, Chirag Pranjali, Vishnu Shankar "Proceedings of IEEE TechSym 2014 Satellite Conference VIT University, Paper on Advanced Low-Cost Security system using sensors Arduino and GSM communication module."
- 6) Deepali Javale, Mohd. Mohsen, Shreerang Nandewar, Mayur Shingate, "Home Automation and Security using Android ADK", March, 2013.
- 7) Mahendran.N, Geo Joe Mathai, Veenesh. M.U, Multiple Sensor Feeding Supported Building Automation System Using Arduino Platform With Exposure of 802.15.4 Functionalities, International Journal of Engineering Trends and Technology, Vol. 4 Issue2, 2013.
- 8) E. Yavuz, B. Hasan, I. Serkan and K. Duygu. "Safe and Secure PIC Based Remote Control Application for Intelligent Home".
- 9) Q. Qu, Z. Guohao, W. Baohua, "Design of Home Safeguard System." Based on GSM Technique, Electronic Engineer, vol. 32, no. II pp. 76-78, Nov. 2006.
- 10) M. Shankar, I. Burchett, Q. Hao, B. Guenther, "Human-tracking systems using pyroelectric infrared detectors," Optical Engineering, vol. 10, no.45, pp. 106401 (01-10), Oct. 2006.