

# “SMART LPG MONITORING & AUTOMATIC GAS BOOKING SYSTEM”

Shashi kumar<sup>1</sup>, Pranita Padole<sup>2</sup>, Shweta salve<sup>3</sup>, Aditya sachdev<sup>4</sup>, Prof. M.P. Wankhade<sup>5</sup>

<sup>1,2,3,4</sup> Students, B.E. Computer Engineering, Sinhgad College of Engineering, Pune, Maharashtra, India

<sup>5</sup> Professor, Computer Engineering, Sinhgad College of Engineering, Pune, Maharashtra, India

\*\*\*

**Abstract** - In recent years there has been rapid development in technology which has made human life easier in several aspects. LPG is a need of every household but many accidents happen every year due to domestic gas leakage, so it should be used carefully. As safety and security is the most important factor we have proposed a LPG monitoring and gas leakage detection system. In our daily life, we don't know exactly the status of LPG gas completion which leads to inconvenience. Along with the leakage detection we also designed feature of sending message to user about the cylinder requirement.

MQ-2 gas sensor is continuously measuring the concentration of gases in the air and if sensor reading is above threshold, buzzer is turned on. If temperature increases gradually and reaches threshold value, exhaust fan is turned on using DC motor and windows are opened using servo motor. Load cell sensor continuously measures the weight of cylinder and when it goes below certain level, message is sent to the user that cylinder booking is required. Bluetooth module is used for connecting android device with the developed system.

**Keywords:** Arduino Mega, Temperature sensor, TextLocal API, Gas Sensor, Load Cell, servo motor, DC motor.

## 1. Introduction

Today in this present era where technological advances are at its vertex, there is not even a single sector which remains untouched by technology. Technology has not merely established our lives simpler, but also offers a high level of safety and security wherever required. Technological devices are available which provides refuge for all the mankind. In our day to day lives, we all use cooking fuel for cooking our daily meals, but if this fuel gets leaked due to some or the other way and then there is a large possibility of a calamity to occur around. Hazards due to gas leakage are dangerous can cause loss of consciousness or even death. Overall health of a person is badly affected causing dizziness, fatigue, nausea, headache, irregular breathing. If timely actions are not taken then there is possibility of fire which can damage property and contents sometimes human loss may takes place. Also the sudden completion of LPG cylinder is also a problem related to LPG which creates inconvenience in our daily life.

Several standards have been implemented for the gas leakage detection system. There are many existing systems which can detect leakage using different gas sensors. Developed systems have used arduino mega, MQ-2 gas sensor, and some other components. For automatic cylinder booking there is an existing system that does booking using

GSM module. Systems developed till date has either a gas detection module or automatic cylinder booking module. We have developed a prototype which is having both the features that are of leakage detection and gas booking. The main objective of this project is to monitor for LPG leakage to avoid major fire accidents and also provides safety where security has been an important issue and sending SMS to the user about cylinder requirement. Arduino AT328 is the microcontroller used for developing the prototype. All other components are connected to arduino. The system detects the leakage of the LPG using MQ-2 gas sensor and alerts the consumer about the gas leakage by sending SMS. The system measure the weight of cylinder by using load cell sensor. The proposed system uses the TextLoacal API to alert the person about the gas leakage via SMS and status of cylinder. When the system identifies that LPG concentration in the air reaches the specified level then it alert the consumer by sending SMS to registered mobile phone and activates buzzer. When system detects the weight of cylinder below particular level, system sends SMS for cylinder booking. Our system is using HC-05 Bluetooth Module for the connection of an android device with the system.

## 2. Problem Definition

To develop a system which continuously monitors the leakage of LPG gas and alerts user regarding leakage to avoid major accidents. If temperature goes above threshold then it detects fire and takes necessary actions like opening window, turning on exhaust fan. In addition to leakage detection feature of sending SMS to the user for the booking of cylinder is added. System continuously measures the weight of cylinder and sends SMS if weight is below threshold.

## 3. Related Work

Gas Detectors have been in the market for a very long time and have been vastly used. They have wide range of applications and can be found in industrial plants, refineries, pharmaceutical manufacturing, paper pulp mills, aircraft and ship-building facilities, wastewater treatment facilities, vehicles, indoor air quality testing and homes[1]. There are a lot of ways in which the Gas Detectors could be characterized. They are categorized on the basis of what type of gas they detect, what is the technology behind the making of the sensor and sometimes even the components which are used that affect their operation mechanism (semiconductors, oxidation, catalytic, photo ionization, infrared, etc.)[2]. Gas Detectors are also widely characterized as fixed or portable detectors.

#### 4. Proposed System

Proposed System overcomes the shortcomings of existing system. Idea focuses on providing functionalities like detecting gas leakage and informing user if there is possibility of leakage. Also user gets the status of gas level of cylinder.

##### 4.1. Flow of Working

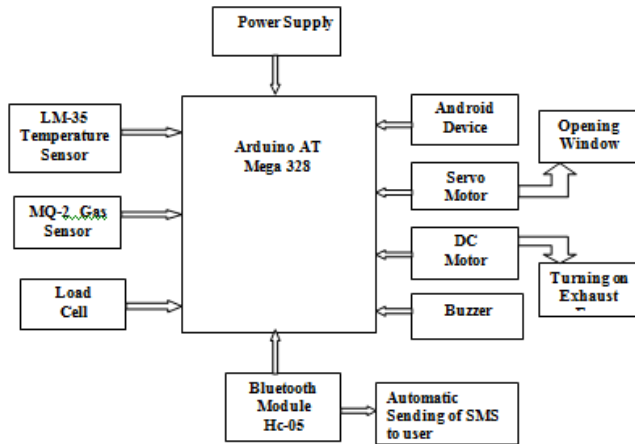

Fig. 4.1 Block Diagram of System

The working of any advanced system is mainly dependent on the microcontroller which controls the entire functioning of the device. In this case the Arduino Uno microcontroller acts like a conditional switch. It performs two set of action depending upon the condition present. It triggers the buzzer and the LCD to display the message “Gas Leak” when the leakage of the gas is detected by the sensor. The other action is to display the message on LCD “No Gas Leak” when the leakage of the gas is not detected by the sensor. If the sensor detects the presence the gas in the vicinity the GSM module will send “Gas Leak” message to the relevant contacts. If no gas is detected by the sensor in the vicinity then the GSM module will not send any messages. Bluetooth Module is included in this device to make the stakeholders aware about the leakage of gas taking place at their house in their absence so that necessary actions can be implemented immediately to prevent an accident.

#### 5. Implementation

Proposed prototype provides an alarm system which is mainly meant to detect an Gas leakage in the house and commercial premises. The objective of the system is to continuously measure the weight of the cylinder and as soon as it reaches the minimum threshold it will automatically sends an SMS alert to the user as well as Authorized LPG agent so that they can act accordingly. System also provides feature like opening windows using DC motor and turning on exhaust fan using servo motor.

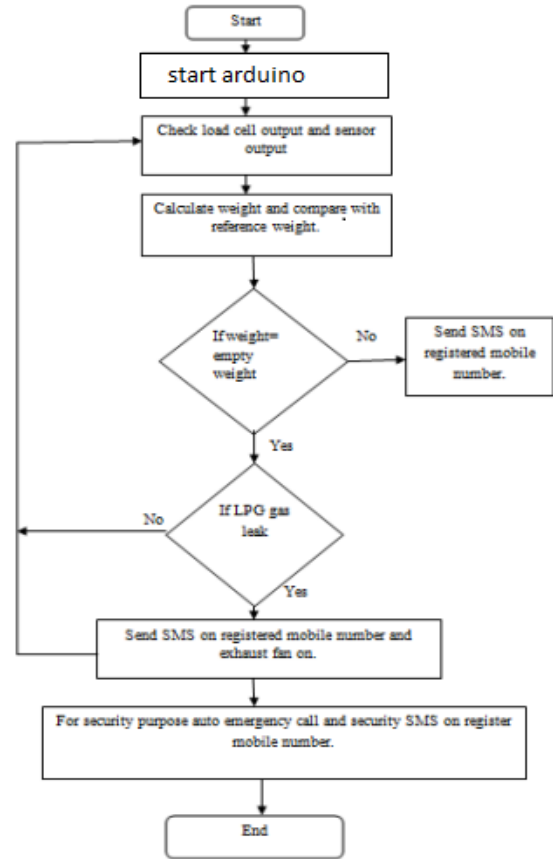

Fig-4.2 Flowchart of load cell

##### 5.1. Arduino Board

ATMEGA328P Board is a powerful development platform based on ATMEGA328 microcontroller which is one of the most feature rich AVR microcontroller from Atmel, featuring 128K Flash, 4K RAM, 53 I/O lines arranged in seven 8 bit ports, 8 ADCs, 2 UARTs, 4 timers, 8 interrupts and much more. This board is mainly used for developing embedded application involving high speed wireless communication, real time data monitoring and control, interactive control panels. ATMEGA328P Development Board has all microcontroller pins in proper PORT wise configuration. Analog Input pins are from A0-A7 and Digital pins are from D2-D12. It has one GND, RESET (RST), RXD, TXD and One microcontroller. USB jack is connected with PC It requires input voltage of 7-12 volt. We can also give power supply using external sources other than USB port.



Fig-5.1 Arduino nano

### 5.2. Gas sensor

MQ-2 Sensor is the back bone of this device and it senses the presence or absence of the lpg gas[7]. This detector has a fast reaction and induces a stable and long lifetime. It provides high sensitivity not only to LPG but also to iso-butane, H<sub>2</sub>, LPG, CH<sub>4</sub>, CO, Alcohol, Smoke and propane. It has very low sensitivity to alcohol and smoke. The basic height of the sensor is 23 ± 5% mm and it has a width of 20 ± 5% mm. The detector can detect the gas concentrations anywhere from 200 p.m. to 10000 p.m. It detects concentration of gas in air.

We set threshold value 270 ppm. If Sensor reading is greater than threshold then leakage detected otherwise leakage note detected.



Fig-5.2 MQ-2 gas sensor

### 5.3. LM-35 Temperature Sensor

LM35 is a precision IC temperature sensor with its output proportional to the temperature (in °C). The sensor circuitry is sealed and therefore it is not subjected to oxidation and other processes. It has 3 pins VCC ,GND and input analog pin It also possess low self heating and does not cause more than 0.1°C temperature rise in still air. The operating temperature range is from -55°C to 150°C. The output voltage varies by 10mV for every 1 °C rise/fall in ambient temperature, *i.e.*, its scale factor is 0.01V/°C.

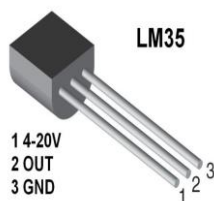

Fig-5.3 LM-35 Temperature sensor

### 5.4. Load cell sensor

Load cell sensor is device used to measure weight .It is a passive transducer or sensor which converts applied force into electrical signals. They are also referred to as “Load transducers”. We are using Load cell sensor for measuring weight of cylinder .Load cell sensor continuously measure weight of cylinder if weight of cylinder is below particular level then it will send sensor value to arduino board com 3 port from where we fetch the data come from sensor and using TextLocal API we automatically book gas cylinder

using number store in memory and also send message to owner. For a 120Ω gauge, this is a change of only 0.12Ω. 0.12Ω is a very small change, and, for most devices, couldn't actually be detected, let So we are going to need another device HX711 which is a amplifier and this amplifier able accurately measure super small changes in resistance.

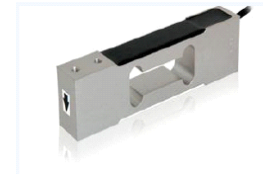

Fig-5.4 Load cell sensor

### 5.5. Bluetooth Module ( HC-05 )

Bluetooth Module connects android device to arduino board. HC-05 Bluetooth Module has 6pins. RX of Bluetooth module is connected to Tx of Arduino board and Tx of Bluetooth module is connected to Rx of arduino board. Supply Voltage of Bluetooth module is 3.3V to 5V which is connected to 5v pin of arduino.

HC-05 Bluetooth Module has 6pins. They are as follows:

**ENABLE:** When enable is pulled LOW, the module is disabled which means the module will not turn on and it fails to communicate. When enable is left open or connected to 3.3V, the module is enabled *i.e.* the module remains on and communication also takes place.

**VCC:** Supply Voltage 3.3V to 5V

**GND:** Ground pin

**TXD & RXD:**

These two pins acts as an UART interface for communication

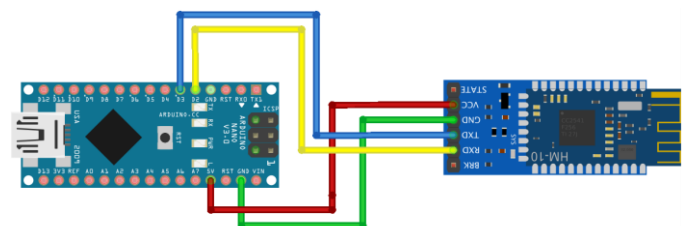

Fig-4.2.5 Connection of HC-05 Bluetooth Module with arduino

### 5.6 Servo motor

In proposed prototype Servo Motor is used to open and close window. If gas leakage or fire is detected then it automatically opens the window. Its operating voltage is 4-6 volt. Servo motor consist three pin VCC, GND and signal pin. Initial position of servo motor is 0 degre. If gas or fire is detected then it will be rotated by specified angle in order to open or close window.



**Fig-5.6 Servo motor**

### 5.7 DC motor

We are using DC motor for exhaust fan. It has 2 pin one for ground and other for input signal. Ground is connected to GND of arduino and input pin is connected to arduino D7 pin number

### 6. Future Scope

This monitoring system can be further enhanced by using Ethernet in place Bluetooth module in order to operate from anywhere, which supports the another real-time application. For industrial purposes , robot can be developed for detecting multiple gas concentrations and fire. Instead of load cell sensor we can also be used as pressure sensor which detects the amount of gas in the cylinder and also detects pressure of gas in cylinder pipe, alerting owner via call and Monitoring by using Android device from any remote location.

### 7. Acknowledgement

I feel great pleasure in my deepest sense of gratitude and sincere thanks to my guide Prof. M.P. Wankhade for his valuable time during the project work without which it would have been very difficult task.

### 8. Conclusion

Our system is reasoned to help customers to upgrade their safety norms, act in accordingly with minimum requirements on environmental issues and mostly the basic function being prevented by major disasters and protect life and property from reputed Accidents. The objective of our project is to measure the gas present in the cylinder when weight of the cylinder is below the particular level , this can be done using the weight sensors. The gas retailer gets the order for a new cylinder and the house owner (consumer) receives the message regarding the status and the secondary objective is to provide any malfunction in gas servicing system in order to prevent damage or explosion of LPG.

### 9. References

[1] Asmita Verma, Prabhakar S, Kayalvizhi Jayavel, " Gas Leakage Detection and Smart Alerting and Prediction using IOT", IEEE, 2017.

[2] Arpitha.T , Divya Kiran , V.S.N. Sitaram Gupta, "FPGA-GSM based Gas Leakage Detection System", IEEE, 2016.

[3] Mr. Akshay D. Prabhu, Mr. Ashwin D. Pathak, "Gas Leak Detector using Arduino UNO Microcontroller", International Journal for Research in Applied Science & Engineering Technology (IJRASET), Volume 5, July 2017.

[4] R.NareshNaik, P.SivaNagendra Reddy,S.Nanda Kishore, K.Tharun Kumar Reddy, "Arduino Based LPG gas Monitoring & Automatic Cylinder booking with Alert System", IOSR Journal of Electronics and Communication Engineering (IOSR-JECE), Volume 11, August 2017.

[5] Ashish Shrivastava, Ratnesh Prabhaker, Rajeev Kumar and Rahul Verma, "GSM based gas leakage detection system", International Journal of Technical Research and Applications, Volume 1, June 2013.