

Design and Implementation of Motorcycle speed Controller System for Restricted Areas

Kavita Katole¹, Mrs. P.R.Morey², Mrs.S.P.Balwir³

^{1,2,3} Asst. Prof. Department of Electronics Engineering ,DBACER ,Nagpur

Abstract – This paper presents an automated system to control the speed of the motorcycle, when it enters in a restricted areas like school or hospital. In this system a prototype is designed with the controller, servomotor and RF (radio frequency) wireless communication. The RF transmitter is fixed at the restricted areas. The speed of the vehicle can be controlled through RF communication in the zones. The RF transmitter transfers the encoded signal to RF receiver. Depending on the message received from RF transmitter, the controller controls the speed.

Key Words: restricted area, RF transmitter ,speed controller, servo motor, microcontroller

1. INTRODUCTION

Safety is a necessary part of man's life. Due to the accident cases reported daily on the major roads in all parts of the developed and developing countries, more attention is needed for research in the designing an efficient vehicular system. It is expected that if such a device is designed and incorporated into a motorcycle as a road safety device, it will reduce the incidence of accidents on our roads and various premises, with subsequent reduction in loss of life and property. When it comes to the use of a motor vehicle, accidents that have occurred over the years tell us that something needs to be done about them from an engineering point of view.

Accidents are occurring frequently in restricted areas .Drivers drive vigorously without caring the traffic. Intimation of driver about speed and accident prone zone is necessary. It can be done by using automatic technology with the help of embedded system and sensors. This project is focused on "automatic speed control of vehicles" by detecting the accident prone zone. The main objective is to design a Smart Display controller meant for Vehicle's speed control and monitors the zones, which can run on an embedded system.

Automation of the driving control of vehicles is one of the most vital need of the hour. This technology can very well implement what was absent before, controlled lane driving. Considering the hazards of driving and their more pronounced effect on vehicles our AUTOMATIC VEHICLE SPEED CONTROL SYSTEM is exactly what is required.

2. WORKING

The proposed system consist of Transmitter and receiver section, Figure 1shows receiver section implemented on vehicle. Figure 2 shows the block diagram of transmitter section which is placed in the restricted area.

The receiver assembly with ATMEGA16 microcontroller is implanted in the vehicle. If any vehicle enter in the restricted area then the transmitter will send the signal to vehicle. At the receiver 12v dc supply is connected which provide power to circuit. Generally controlling speed in this areas must be 40KM/ph .

When the vehicle enters into the restricted areas, the transmitter module just send an information that contains how much speed a vehicle can go inside this area. then the signal or information is received by the receiver and the signal acquired from the speed meter is also given to the controller. the signal is basically analog in nature that will be converted into digital so only the micro controller able to process the signal. The signal from the transmitter and the speed meter is compared by the controller.in this there are two case: first,the current speed is less than the transmitted speed the vehicle goes normally no action is required. second,the information from the speed meter is greater than the transmitted speed by the transmitter module the controller waits for few second whether the driver reduce the speed to the below value if the driver does not reduce the speed means it automatically takes the control and reduce the speed according to it.at the same time the information is transmitted to

2.1 Receiver Section

Receiver and controller circuit also containing the supply and VOLTAGE REGULATOR IC(7805 IC)which convert 12V DC supply to 5V DC. After conversion voltage supplied to all component .Such as Microcontroller ,LCD ,Electronic Accelerator ,Decoder IC ,and RF Receiver. After microcontroller start it get the real time speed of electronic accelerator and show in LCD .Our objective is to control vehicle ,but instead of vehicle we control SERVO MOTOR. This motor having the ability to work in angle position as per programming in microcontroller.

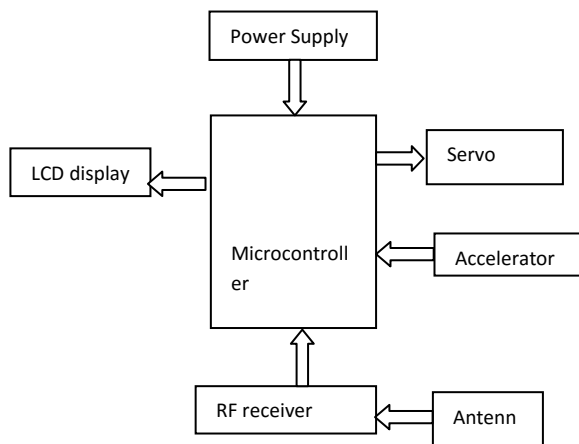

Fig1: Receiver section

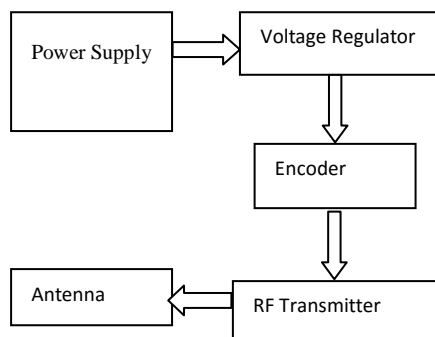

Fig2: Transmitter section

2.2 Transmitter Section

Here microcontroller programmed to work servo motor as on 0 to 90 degree angle , as well as in different mode with different angle. Electronic accelerator is use for varying speed /angle of servo motor.

Microcontroller works on two modes:

1. NORMAL MODE
2. ACTIVE/CONTROL MODE

In normal mode RF receiver continuously search transmitter frequency .When it does not get the transmitted frequency receiver send 1 bit to controller .As per programming when 1 bit is received servo motor input remains unchanged and motor work normally upto maximum speed/angle.

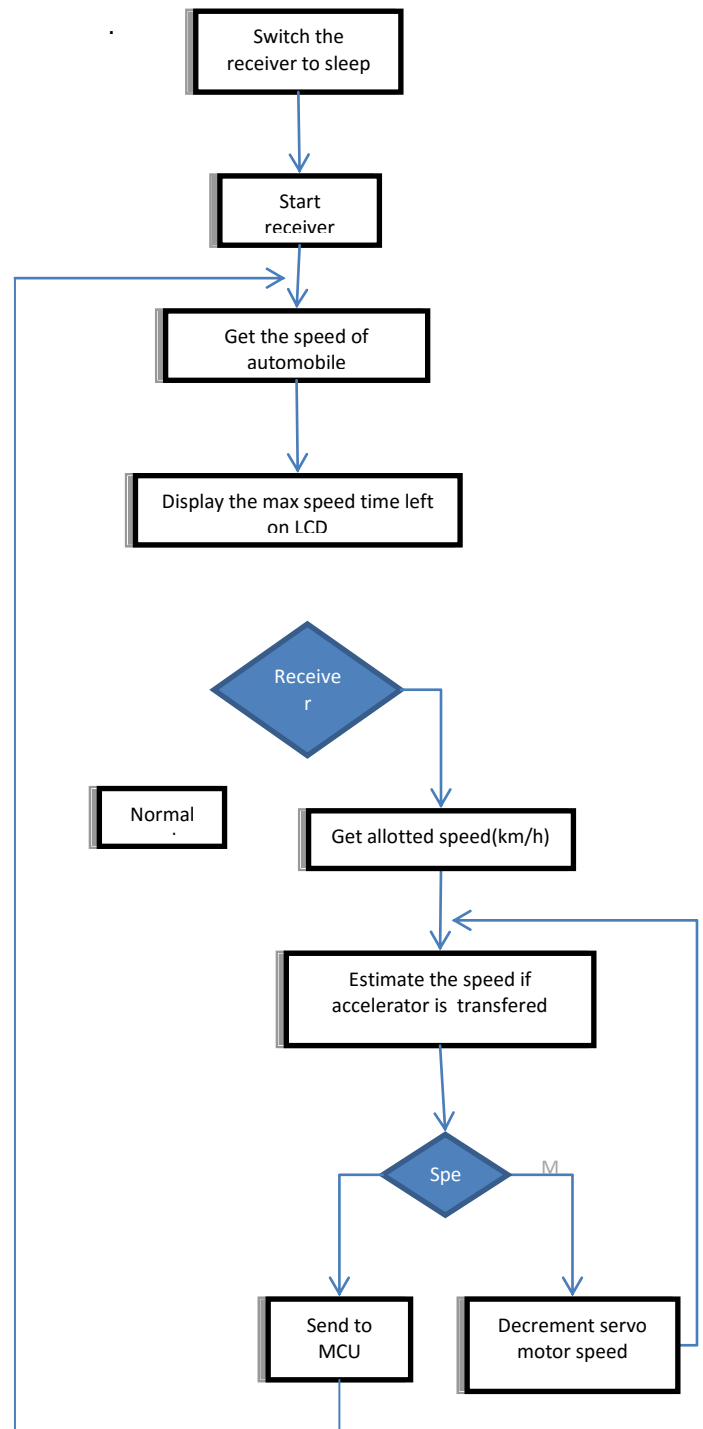

Fig 3: Flow Diagram

In active /control mode PWM signal is continuously send from controller which give the servo motor work on minimum to maximum angle or speed. When RF receiver receives the transmitted frequency from transmitter then data is decoded and decoder sends bits to controller. As per the program when 0 bit is received by controller then servo motor speed will reduce to 40 degree/speed ,hence maximum speed of servo motor is 40 km/hr.

vehicle ,but instead of vehicle we control SERVO MOTOR. This motor having the ability to work in angle position as per programming in microcontroller

Usually people drive very harshly in restricted areas as they are in a hurry, but in that hurriedness they often end in loosing either their life or someone other life on road.

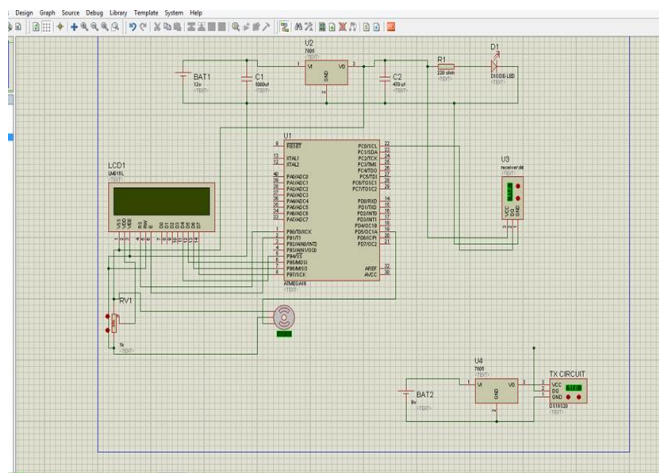

Fig 4: Circuit Diagram

This system has a great significance in termination and reduction of overall accidents and casualties in the restricted areas.

REFERENCES

[1] Amarnarayan¹, Challa Saikumar², Chandra Mohan³, Ajaykumar⁴, Sridhar N⁵, Automatic Over speed Controlling of Vehicle, International Journal of Combined Research & Development (IJCRD) eISSN:2321-225X;pISSN:2321-2241 Volume: 5; Issue: 5; May -2016

[2] "The 8051 Microcontroller & Embedded Systems" by Mohammed Ali Mazidi and Janice Gillispie Mazidi

[3] Leena Thomas¹, Swetha Annu James², Seril Joseph³, Arya K B⁴, Tedik Narah⁵, Automatic Speed Control of Vehicles Using RFID, International Journal of Engineering and Innovative Technology (IJEIT) Volume 3, Issue 11, May 2014.

Sr. No.	Normal Condition Accelerator Output Voltage	Servo Motor Angle Movement
1	1	19 Degree
2	2	38 Degree
3	3	57 Degree
4	4	76 Degree
5	5	95 Degree

Table1: Angular movement of motor with increasing voltages



Fig 5: Proposed system

3. CONCLUSIONS

This paper presents a system that checks the speed of the vehicle through electronic accelerator and transmitted using RF transmitter. Then warning signals send to driver to lower down the speed. In case driver doesn't reduce the speed then within seconds our system will take over the control and will reduce speed of vehicle automatically.