

STUDY OF BREAKDOWN PHENOMENON IN SOLID INSULATORS USING SPHERE GAP AND INSULATION TESTING KITS

Suvodeep Chakraborty¹, Rohit Patil², Prof. Y.B. Mandake³

^{1,2}Student, Electrical Department, Bharati Vidyapeeth College of Engineering Pune, Maharashtra, India

³Professor, Electrical Department, Bharati Vidyapeeth College of Engineering Pune, Maharashtra, India

Abstract - One of the major issues of the high voltage engineering is the degradation of the insulation of the solid material. It has been revealed through the several researches and studies that the high voltage power equipment are directly and mainly subjected with the spark over voltage. The sphere-sphere electrode arrangements and insulation testing kit are mainly used for the measurement of the breakdown values of the high voltages as adopted by the IEC and IEEE. The effect of the voltage on different insulation like Acrylic material, paper insulation, press-board, wood and PVC has been studied. The determination of the breakdown voltage of various insulating material gives a major area of interest to the electrical engineers. Therefore, the possibility of developing solid insulating materials with excellent breakdown strength is viable through study and research. Thus in our research we found out that the breakdown voltage for non uniform electric field is higher than that in uniform field applications. This is exhibited in our paper from practical perspective.

Key Words: Solid insulating material, breakdown voltage, sphere gap arrangement, insulation testing kit, high voltage.

1. INTRODUCTION

The application of high voltages in electrical engineering leads to degradation of the insulation of the solid insulating material. It has been foreseen from previous researches that high voltage equipment are subjected to over-voltages and lightning. Generally in the electrical power equipment, the standard sphere gaps are widely used. Therefore, sphere-sphere electrode arrangements and insulation testing kits are used for this research and the measurement of the peak values of the high voltages as adopted by the IEC and IEEE. The effect of the breakdown voltage on different insulation like Acrylic material, paper insulation, press-board, wood and PVC has been studied. To study and observe the effect on insulation of the solid material due to breakdown mechanism, high voltages through H.V. transformers are applied and characteristics graph is plotted. The determination of the breakdown voltage of various insulating material gives a major area of interest to the electrical engineers.

Therefore, the possibility of developing solid insulating materials with excellent breakdown strength is viable through study and research. The few basic and important

topics affecting the breakdown and study of different composite insulating materials are reviewed[2].

2. SPHERE GAP UNIT

Two spherical electrodes of equal diameters are placed in vertical or horizontal manner with constant gap spacing with the insulating material placed between them. As the voltage is increased via regulators and through transformer, spark-over occurs on the insulators which provide us the breakdown voltage. Measurement voltage is made as a function of minimum distance at which it can flash over or spark-over[4].

2.1 COMPONENTS OF SPHERE GAP UNIT

- **Control unit**

The control unit comprises of a switch which controls the increase and decrease in gaps between the spherical electrodes coupled to mechanical gears. This unit also consist of voltage supply up to 75 KV and can be changed using a regulator as needed.

- **H.V. Transformer (200V/60 KV, 3 KVA)**

A single phase, 50Hz testing transformer of input 0-250V and step up output of 0-75 KV is connected from the voltage source to the fixed electrode on sphere gap[1].

- **Spherical electrodes (sphere diameter 6.25 cm, 14KV -115KV)**

The sphere gap consists of two electrodes, one fixed and one moving. This arrangement of movement of space between the air gap is possible due to presence of mechanical gears connected to the control unit. As the current passes through the medium between the electrodes, a spark is generated in this gap depending on the air gap distance or the insulation used[3].

This sparking provides us the breakdown voltage of the material inserted between the electrodes.

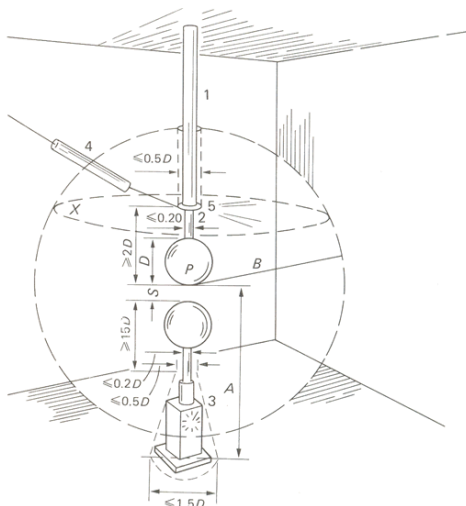

FIG 1 : Sphere Gap Arrangement

3. INSULATOR TESTING KIT

This kit comprises of two dissimilar electrode configuration, i.e. one plate type and another rod type arrangement. The insulators is placed between them and voltage is increased[8]. The specification of this kit are -

Control Panel

- Input Supply : 1ph, 230V AC, 50Hz
- Timer : 0-30hr configurable timer
- Meter : Variable Input voltage (Analog)
- AC Charging Voltage (Analog)
- Leakage Current (Analog)
- Variac rating : 3A
- Type : Manual control through knob
- Controls : Through push buttons

HV Transformer

- Input Voltage : 0-230V AC
- Output Voltage : 0-30kV AC
- Leakage Current : 30mA

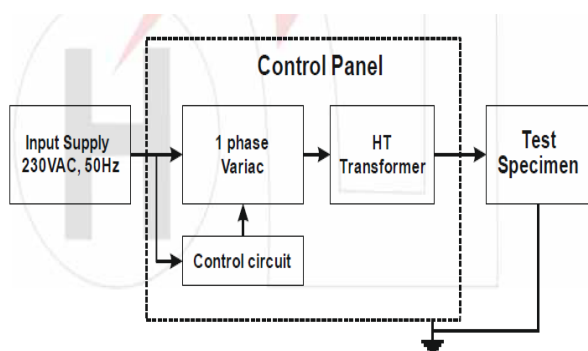

FIG 2 - Block diagram of Insulation Testing kit

4. PROCEDURE

1. Cut the insulation sheet to different diameters.
2. Place the insulation sheet between the electrodes. Confirm physical contact of electrode with insulation sheet.
3. Confirm proper connection between H.V. transformer and the electrode. Confirm the connection and earthing wire to H.V. & sphere gap assembly.
4. Apply voltage using dimmer-stat and observe the spark over on the material.
5. This voltage is recorded as breakdown voltage and measurements are taken at different thickness.

5. OBSERVATION

When press board insulation sheet sandwiched between 2 electrodes are subjected to high voltages , a high volume of hissing sound is heard[4].

1. A blue ring along circumference of electrode (touching) insulation paper is observed.
2. Heavy sparking at weakest section of insulation paper forming conducting channels which are permanent in nature.
3. Due to large surface flash over many tree are observed on paper which was under non-uniform field.
4. This provides us with the breakdown voltages of the different materials used in the experiment.

6. RESULTS AND GRAPHS

Material used - Press-board Paper

S. N o.	THICKNESS (mm)	BDV OF INSULATION KIT (kV)	BDV OF SPHERE GAP UNIT (kV)
1.	1mm	8	5
2	2mm	15	10
3	3mm	21	15

Material used - Acrylic Sheet

T. N o.	THICKNESS (mm)	BDV OF INSULATION KIT (kV)	BDV OF SPHERE GAP UNIT (kV)
1.	1mm	18	16
2	2mm	35	32
3	3mm	50	48

Material used - Insulation Paper

U. N o.	THICKNESS (mm)	BDV OF INSULATION KIT (kV)	BDV OF SPHERE GAP UNIT (kV)

1.	1mm	28	7.5
2	2mm	52	16
3	3mm	78	37

Material used - PVC Sheet

V. N o.	THICKNESS (mm)	BDV OF INSULATION KIT (kV)	BDV OF SPHERE GAP UNIT (kV)
1.	1mm	17	8
2	2mm	35	17.5
3	3mm	67	37

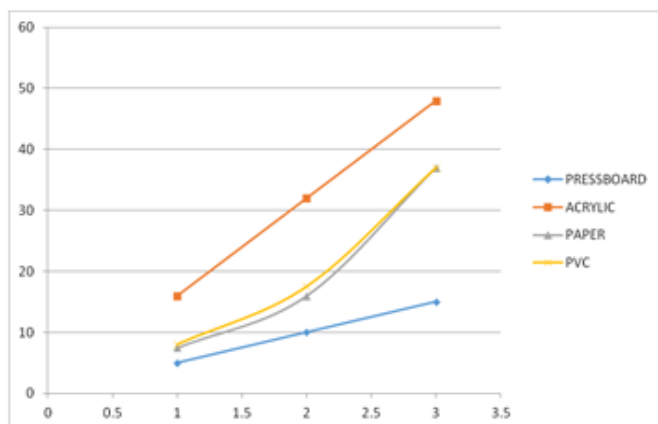

GRAPH 1 : BREAKDOWN VTG VS THICKNESS ON SPHERE GAP UNIT (UNIFORM ELECTRIC FIELD)

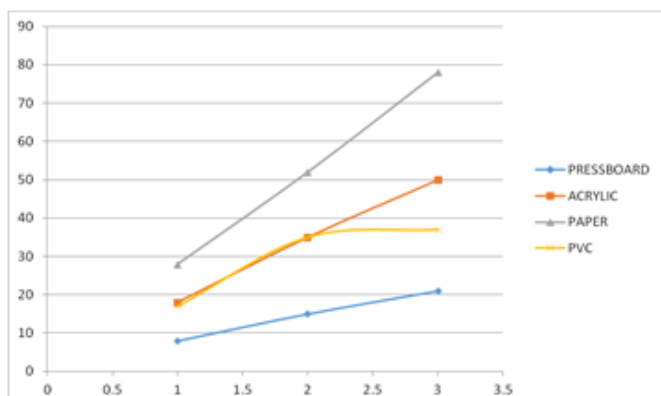

GRAPH 2 : BREAKDOWN VTG VS THICKNESS ON INSULATION TESTING KIT (NON UNIFORM ELECTRIC FIELD)

***NOTE** - The graphs 1 and 2 lead us to conclude that the breakdown voltage of solid insulating materials are much higher under the influence of non-uniform electric field (insulation testing kit) and lower in case of uniform fields (sphere gap unit).

CONCLUSIONS

The dielectric losses per cubic centimetre in a given material and at a given temperature are directly proportional to the frequency of the electric field and to the square of the field strength. Hence the decrease in breakdown voltage with increasing time of application and increasing temperature and also the dependence of this voltage upon the shape, size, and material of the electrodes and upon the form the electric field

The measurement of dielectric loss in insulating materials are very important, as they give a fair indication as to comparative dielectric strengths of such materials.

Further from the research we can conclude that due to presence of non uniform field, the breakdown voltage required for flash over in case of insulation testing kit is much higher than uniform field breakdown voltages in sphere gap unit.

REFERENCES

- [1] C. L. Wadhwa, "High Voltage Engineering", published by New Age International (P) Limited, 2nd edition 2007M. Young, The Technical Writer's Handbook. Mill Valley, CA: University Science, 1989.
- [2] K.S. Naidu, S.K. Jain, V.N. Maller and P. Satyanarayana, "Partial discharge studies in non-uniform fields with insulating barriers", IEEE Transaction on Electrical Insulation, Vol. EI-14, No. 5, 1979, pp. 285-287.
- [3] T.W. Dakin, H.M. Philofsky and W.C. Divens, "Effect of electric discharges on breakdown of solid insulation", Transactions A.I.E.E. Electrical Insulation, 73, pt.1, 1954, pp. 155-162.
- [4] M.S. Naidu and V. Kamaraju, "High Voltage Engineering", published by Tata McGraw-Hill 3rd edition, 2004.
- [5] Chao Tang*, Rui-jin Liao, Li-jun Yang, Fei-long Huang "Research on the dielectric properties and breakdown voltage of transformer oil-paper insulation after accelerating thermal ageing.", 2010 IEEE
- [6] LUCIANO SIMONI AND GIANNI PATTINI " A new research into the voltage endurance of solid dielectrics", 1975 IEEE
- [7] "BREAKDOWN IN SOLID DIELECTRICS", J. J. O'Dwyer, 1982, Department of Physics SUNY/College at Oswego, NY
- [8] H.V. Tester Instruction Manual (30kV AC, 30mA) by High Voltage India, Bengaluru, Karnataka.