

Detection of Hazardous gas using Land Rover Robot in Mines First

Deepan A¹, Jayakrishna S V², Nagha abirami S S³, Vanmathi M E⁴, Andril Alagusabai⁵

^{1,2,3,4}UG Student, Knowledge Institute of Technology, Salem-637504

⁵Assistant Professor, Knowledge Institute of Technology, Salem-637504

Abstract-Human exposure to poisonous gases while working in underground tunnels may create fatal effects. To avoid such cases we have to automate the system with the application of certain Robots. The robot here detects the hazardous gas and monitor using a wireless control like Bluetooth in mines. The MQ-4 sensor detects the level of methane (CH₄) and the Wireless Camera which is used to monitor the operations in the mines. In various mining areas, industrial applications and garbage places this robot can be used. It can be enabled to detect other gases like Carbon Monoxide, Carbon Dioxide, Low O₂ content, Smoke and other gases. Robot can provide the prior knowledge to the workers about the level of danger and so the workers can have preparatory plans which will reduce loss of human life due to disaster by enhancing the effective operation in mines.

Keyword: Mines, MQ-4, CH₄, Wireless Camera and Bluetooth.

I. INTRODUCTION

Coal mine is an underground tunnel system. The tunnel is narrow if there are some accidents the workers are easily trapped inside and it is very difficult for the workers to get out of the mines. In some situation the workers cannot escape from it. There may be sudden landslides or collapse in the mines. Dangerous accidents occur in mines due to gas explosion, CO, CO₂ poison gas, low O₂ content, high temperature, smoke, fire, water, etc. CH₄ (methane gas) is poisonous. CH₄ is an intergrowth with coal. During the process of mining CH₄ may be released from the coal layer into the environment. The gas diffuses throughout the tunnel and it causes gas explosion. As the pathway of the tunnel is narrow the gas explosion may destroy the devices and workers present in the mines. The gas cannot be pushed out from the tunnel and it creates harm to the workers. Besides the poisonous gas coal mine also has some dangerous like low O₂ content and coal dust. During mining dust is created as the tunnel is narrow it gets accumulated in the tunnel. Detection of the explosion is the first problem in mines. Communication is another problem because electromagnetic waves are absorbed and reflected in the mines. Because of many corners in the tunnel, Wave cannot cross these corners. The modern world and its researches has made a tremendous change in the field of computer science and engineering. The mining industries are facing many problems due to explosion and gas leakage in mines. To overcome this problem robot has been developed. Robots are developed to work in mines so human work is replaced by robots. This mine detecting robot is used for detect the gas leakage using MQ-4 sensor and wireless camera take picture of mines. This robot can move in any type of field and

also capable of climbing steps. The movement of robot is controlled by a remote which communicate with the robot through blue tooth.

II. LITERATURE REVIEW

Hazardous Gas Detecting Rescue Robot In Coal Mines T S Kumar Reddy, G Bala Siva Krishna describes that it is harmful for the rescues to get into the mines without the prior knowledge of the environment. Because explosion may occur at time. The explosion may be landslide, gas leakage, high temperature and others. To detect the explosion such as toxic gas and high temperature a robot is developed. This robot has a wireless camera for monitoring purpose.

Coal Mine Robot For Detection Of Hazardous Gas S. D. Mitragotri, Dr.A.R. Karwankar describes that safety of human is important. Accidents occur due to poisonous gas (CH₄), CO, CO₂ and low O₂ content. The robot moves inside the coal mines it detects the gas leakage and transmits the leakage range through Zigbee.

Hazardous Gas And Mine Detecting Robot Sharathsethuraghavan, Jasim M describes that gas detecting robot is a new generation robots which provides an answer to the problems of coal mines and provide an ease to the militant operations in war fields. The robotic vehicle is attached with sensor and wireless camera. Sensor detects the poisonous gas and camera is used for capturing pictures and videos.

Advanced Rescued and Monitoring for Coal Mine Jayant Nivritti Patil describes that rescue operation in coal mine is extremely dangerous. It is danger for the workers to get into the mine without any prior knowledge of the environment in mines. Explosive may occur at any time so to detect the explosive like toxic gases, high temperature and others robot is used in mines.

III. EXISTING METHOD

A robot was developed to minimize the human and material loss that happens during rescue operations in coal mines. The Robot is used to get in to the disaster zone and detection of research operations. Robot can go in to mine and detect butane levels, temperature, gas contents. In the existing method the four wheel system has certain complications in the movement in terrain surfaces, this is rectified in the proposed model we use six wheels so the robot can move in all kind of surface like terrain and it can also climb rocks, steps.

IV. ROPOSED METHOD

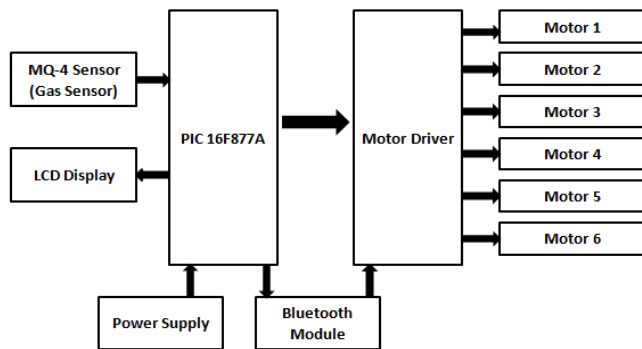

Figure. 1 Block Diagram

A. DESCRIPTION OF PROPOSED METHOD AND ITS FUNCTIONAL UNITS

The block diagram shows the functional flow of how the robot works. The vital components of the proposed system includes sensors, control unit, Bluetooth, wireless camera and supply unit. Bluetooth is used for transferring data and message. All of these sensors are directly connected to the PIC (6F877A) micro-controller which has default program in it. The working energy for the robot is obtained from the battery connected to the PIC microcontroller.

The main aim of this robot is gas detection and screening the operation in mines. MQ-4 is used for detecting hazardous gas and PIR is used for detecting obstacles. Wireless camera is used for screening the operation in mines. The visualization of all details is done by using the wireless LCD connected to the robot, so that all details of the environment can be traced easily.

B. ROBOT STRUCTURE

After taking account of the issues on coal mines, we have developed a robot. Robot is composed of mechanical vehicle, control system, driving system, communication system and sensors. This robot is made of light weight frame and 6 dc gear motor is used to drive the robot vehicle. Motor power is 30W and speed is 100rpm. The motion of robot is done by placing 3 motors on each side. The robot can move front, back, left and right side and even used for climbing rocks.

C. SENSOR UNIT

Sensor is used to measure physical quantity and convert it to signal. This signal can be read by the observer. In mines sensor is used to sense hazardous gases, temperature and humidity. MQ-5 sensor is used to detect poisonous (methane) gas. PIR sensor is used to detect the obstacles around the robot. Temperature sensor is used to measure the temperature inside the mines. The values read by the sensors are transmitted to a PIC where it compares the measured value with that of the set points and if the measured value gas above the set points, intimation will be

given to the workers saying “gas level has exceeded”. The gas level will be displayed in LCD.

D. BLUETOOTH MODULE

Wi-Fi is a good transmission system but it is explosive to nature .So Bluetooth is used for transferring message, pictures and videos.

E. WIRELESS CAMERA

The environment in the mines can be monitored using wireless camera. Images can also be spotted. The camera is connected to the screen wirelessly.

F. PIC

PIC 16F877A is used .PICs are low cost, easily available, it has large user base and serial programming capability. It is used to collect the parameter value from the sensor unit and compare it with the set point and transfer the corresponding data to the CPU. PIC 16F877A is a 8-bit. It has 40 pins and 256 bytes. Operating voltage of this PIC 16F877A is 2 to 5.5v. It uses Flash memory and it is self programming. The robot can be controlled in both manual mode and automatic mode most of them work in manual mode. The automatic mode robot is programmed within the embedded chip.

V. CONCLUSION

The mine robot for gas detection and disaster surveillance is developed with sensors, camera and other components. An 11v/4A battery is used to run the robot. MQ-4 sensor is used for gas detection and a wireless camera is used for surveillance. The robot can run in terrain surface and climb rocks in the mines. When the measured value exceeds the set points intimation will be given to the workers saying “gas level has exceeded”. The gas level will be displayed in LCD. This robot is used for monitoring the operation and gas leakage to protect Human (workers) and provide safety to enhance detection operation defensively. In 2012, 92 workers were died due to methane gas leakage in Turkey china , to prevent these disasters our proposed system will be a boon.

VI. REFERENCE

- [1]Pratima Bhagat, kishori Birdawadc, Komal Amle; “Rescue robot for hazardous coal mines”, International Journal of Technology and Science, Issue-2, Vol.1, May 2014
- [2]T.S. Kumar Reddy; G. Balasiva Krishna; “Hazardous gas detecting rescue robot in coal mines”, International Journal of Mechanical and Production Engineering, ISSN:2320-2092, volume2, Issue-5, May-2014.
- [3]Mr. Sabarish Chakkath, S. Harihara Siddharth, B. Hemalatha; “Mobile Robot in Coal Mine Disaster Surveillance”, IOSR Journal of Engineering, (IOSRJEN), e-ISSN:2250-3021, Volume-2, Issue 10, October 2012.