

Automated Water Conservation and Theft prevention using IOT

Elakiya Bharathi V^[1] Jaishnu M^[2] Padhmavathi K^[3] Premkumar S^[4] & Sasikumar S^[5]

^[1,2,3,4]UG Student, Knowledge Institute of Technology,Salem-637504

^[5]Assistant Professor, Knowledge Institute of Technology,Salem-637504

Abstract: Today's world is growing rapidly in urban residential area ,to avoid water scarcity of water problems and requirement of consumers. It is supposed to supply adequate water distribution networks are managed automatically. Along with this another problem in the water supply system is that public is using suction pumps to suck the water directly from the home street pipeline. In this project it is proposed to develop an IOT based remote water monitoring and theft prevention system by recording the flow rates at the consumer/user end. In order to implement the proposed water supply system, each consumer should be provided with an IOT based water flow monitoring system consisting of a MSP to record the flow rate using a flow sensor .The valve turns on/off to stop the water supply whenever the flow rate exceed a predefined limit. The solenoid valves are also controlled using real time clock to control flow of water accordingly for a fixed duration of time.

Keywords: MSP430 Launch Pad, W5100 Ethernet shield , Flow Sensor, Theft identification.

1.INTRODUCTION

As the world is progressing towards the future with an ever growing population and crave to the consumption of water, there would be a need to introduce uniform water distribution in order to avoid imbalance of water in various areas. Over the year the world has been facing with water shortage problems. The monitoring of water resource for these enterprises can prevent the occurrence of stealing water and leaking water effectively. Therefore, the monitoring system of urban water supply has aroused extensive attention in recent years. Urban water supply networks form the link between drinking water supply and drinking water consumers.

The person in charge will go to the place and then open the valve to that particular area. Once the time is over the person will go again to that place and close the valve. This type of operation needs man power. This is waste of time to go to that place and come back often. Also the people may take excess water for their personal use with the help of motor or some other equipment. Due to this many people will not receive sufficient water for their use.

II Literature Review

Literature Review 1

Name of the Journal & Year of Publication:

International Journal of Engineering and Innovative Technology (IJEIT) 2014

Title of the paper: Automated Water Distribution and Performance Monitoring System

Abstract: The integrating system is capable of predicting flow of water, issuable of water with appreciable quality and automatic supply of water. It can be done by employing sensors such as flow sensors and pH sensors.

Hardware Used: LCD , ADC , Control circuit , Control valve , Pipeline , Flow sensor , pH sensor , Microcontroller , Power supply , Zig bee

Software Used: Kiel μ Vision

Applications: Automated water distribution and performance monitoring system focuses on various entities such as proper supply, over consumption alert and water quality assurance

Future scope of work:Future work deals with tasks such as water level detection and intimation of less volume of water in main tanks which are gathered from other tanks located in different places.

Literature Review 2

Name of the Journal & Year of Publication:

International Journal of Innovative Research in Computer and Communication Engineering (2015) **Title of the aper:** Automated Drinking Water Supply System and Theft identification Using Embedded systems.

Abstract: In this project it is proposed to develop an embedded based remote water monitoring and theft prevention system by recording the flow rates at the consumer/user end.

Hardware Used: DMA flow sensor, Opacity sensor , Pressure logger, Service reservoir, Pressure regulating valve, GSM ,Hall Effect Sensor, Solenoid Valve

Software Used: MySQL, Kiel μ Vision

Applications: Automated water distribution and water theft detection.

Future scope of work: We can make centralized water control and theft detection system. We can ensure fair water supply to all users by preventing water theft and ensuring by taking necessary action.

The disadvantage of the existing system that required manpower was eliminated.

Literature Review 3

Name of the Journal & Year of Publication:

International Innovative Research Journal of Engineering and Technology ICEIET-2017

Title of the paper: An Efficient Water Distribution System for India using IoT

Abstract:It is also proposed to employ a IoT modem for wireless communication and hence information is transmitted to many responsible consumers and officers to take immediate action under problematic situation.

Keywords : IoT modem, solenoid valve , flow sensor

Hardware Used: Level sensors , Flow sensor , Microcontroller , PH sensors , Vibration sensor , Pressure sensor

Software Used: Kiel μ Vision.

Applications: It provides a review of smart water distribution and utilization of water resources for every Indian citizen to save the nation from water scarcity

Future scope of work: There is a need for low cost and low maintenance smart water system which is simple for household appliances in terms of data reliability.

III EXISTING METHOD

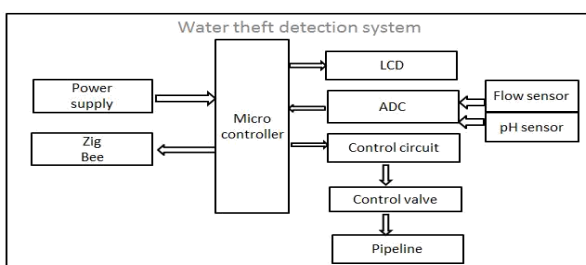

Fig 1: Existing Block Diagram

The system is provided with an electrically operated solenoid valve to supply water to the consumers. The valve turns on/off by the central processing station PC to supply

the water for a particular time period. The system is provided with another electrically operated solenoid valve to stop the water supply whenever the flow rate.

IV PROPOSED METHOD

IV. a. FUNCTIONAL BLOCK DIAGRAM

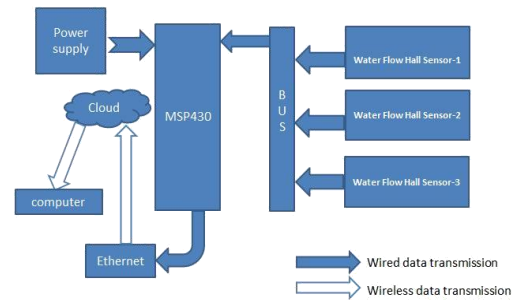

Fig 2: Functional Block Diagram

The existing system is replaced by the Ethernet communication protocol and it feeds the data to the cloud . The cloud on the other hand sends the data to the centralized system . The difference in the volume of water passed from the main tank to the sum of the individual systems will determine whether there is a leakage or theft .

IV. b. DESCRIPTION OF PROPOSED METHOD

AND ITS FUNCTIONAL UNITS

MSP430LAUNCHPAD MICROCONTROLLER

The microcontroller will switch ON/OFF the solenoid valve using a transistor as a switch. It is proposed to employ a GSM modem for wireless communication so that the information can be passed to particular responsible officer's cell phone for immediate action as well as to the central processing database.



Fig 3: MSP430LAUNCHPAD MICROCONTROLLER

- 20-pin DIP processor socket
- Built-in Flash emulation for debugging and programming
- 2xUser LEDs
- Power LED
- User button
- Reset button
- 10-pin header for external circuit connection

- The 16-bit RISC architecture is perfectly suited for wireless, low-power industrial and portable applications. This established range has a strong and popular position due to its ease of use and broad suite of development tools and support.

b. DC 12V MINI WATER PUMP



Fig 4: MINI WATER PUMP

Product description

- Weight: 150g
- Dimension of inlet and outlet: 15mm O.D. / 5mm O.D.
- Working voltage : 12Vdc
- Rated voltage: 12Vdc
- Working current: 0.1A-0.5A
- Lift: 130cm (at 12Vdc)
- Flow rate: 300L/H

C.YF-S201 WATER FLOW SENSOR



Fig 5: WATER FLOW SENSOR

- Connection details:
- Red wire is 5V
- Black wire is GND
- Yellow wire is PWM signal output

Description:

- Lowest rated working voltage: DC4.5 5V-24V
- Maximum operating current: 15 mA (DC: 5V)
- Working voltage range: DC 5~18V
- Load capacity: ≤ 10 mA (DC 5V)
- Temperature: ≤ 80 °C
- Allowed pressure: pressure 1.75Mpa

V SIMULATION

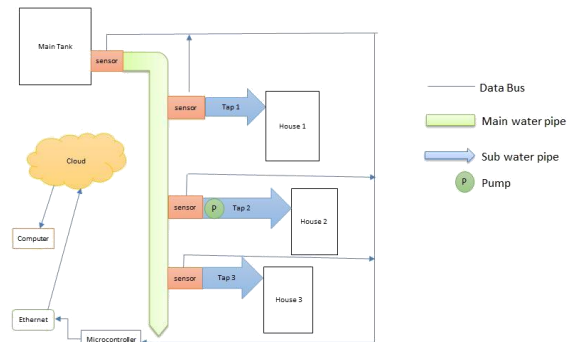

Fig 6: WATER FLOW SENSOR

VI CONCLUSION

The proposed method consists of the IOT (Internet Of Things) based water theft detection and corresponding bills acclaiming by the water board. This will automate the unorganized water supply system to a organized one. In addition to this we can detect water tapping and corresponding measures can be taken in a very fast method with a less cost system , this will also generate a additional revenue to the government . In the present day of Smart lifestyle this is a great requirement as water resources are diminishing slowly.

REFERENCES

- [1] International Journal of Innovative Research in Computer and Communication Engineering (An ISO 3297: 2007 Certified Organization) Vol. 3, Issue 3, March 2015 “Automated Drinking Water Supply System and Theft Identification Using Embedded Technology” Sagar Khole1, Tushar Kolape2, Mrs.A.P.More
- [2] International Innovative Research Journal of Engineering and Technology , International Conference on Emerging Innovation in Engineering and Technology ICEIET-2017 An Efficient Water Distribution System for India using IoT S. Ezhilvanji1 , S. Malarkodi2 1,2PG Scholar, Department of CSE,Christ Institute Of Technology.