

Automated Toll Collection System Using NFC

Prof. Swapnil Gholap¹, Sahil Mondkar², Swapnil Khaire³, Mayur Mhatre⁴

¹Prof. Swapnil Gholap, Dept of Computer Engineering, SSJCOE, Dombivli, India

^{2,3,4} Students, Dept of Computer Engineering, SSJCOE, Dombivli, India

Abstract - This article gives an important guideline for Automated Toll Collection System (ATCS) Using NFC and Theft Vehicle Detection. ATCS comes out/becomes visible as a coming together technology where time and (wasting very little while working or producing something) are important in toll collection systems now/recently. In this, NFC tag will be placed by toll authority having (like nothing else in the world) identification number (UIN) and user details. Active NFC tag will be attached to the vehicle. When vehicle passes through the tollbooth system, data on NFC will be read by NFC Reader and also sent to the server for checking (for truth). Server will check details and toll amount will be deducted from user's account. Theft Vehicle Detection is done with the help of different sets of computer instructions such as OCR and BLOB Detection.

Key Words: ATCS, NFC tag, UIN, NFC Reader, OCR Set of computer instructions, and Blob Detection.

1. INTRODUCTION

Automated toll Collection framework is considered as a viable technique keeping in mind the end goal to conciliate movement blockage and jams, upgrade the comfort and security of voyagers, and minimize fuel consumption and air pollution for environmental protection need. The paper proposes Architecture for collecting toll using Near Field Communication (NFC) technology. The basic idea is that the client having NFC enabled android mobile taps on NFC enabled toll tab at toll station, which reads the information like NFC Id and automatically sends an acknowledgment to the owner of vehicles and simultaneously the request is forwarded to the server. The system proposed shows a high transparency level in transaction and amount collected. The system is able to develop the auto-generated message as acknowledgment for toll station, client and the server. The automated toll collection system is also able to census traffic flow and audit road maintenance fees. This system is necessary to improve expressway management.

2. PROPOSED SYSTEM

In this project, the main aim is to demonstrate secure toll transaction with better interaction features in transaction through website and Android App which can improve the availability of toll collection amount directly to government without any corruption. With help of this

project, transparency will be maintained towards all customers, toll agents and the government. Customers can view their amount deducted, all toll transactions operated successfully with their corresponding toll location referencing through their id, and remaining balance on their respective accounts. The toll agents will be paid a certain salary as per decided amount by the government on the basis of individual toll collection of the month and get cars details for crime detection for police.

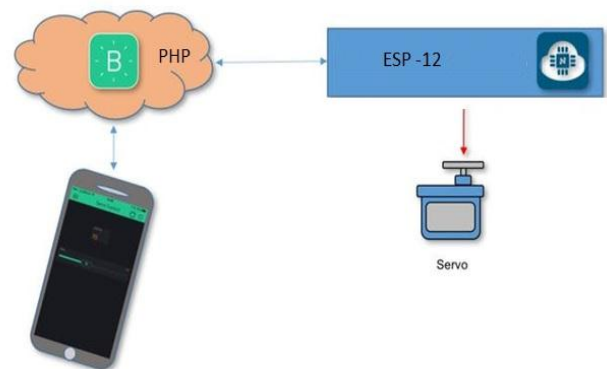

We use servo motor, ESP12 module for making model. NFC Reader reads the card and sends information to ESP 12 module. It then fetches the information from database if condition is satisfied amount is detected and the module then sends command to servo motor which acts as a gate to open

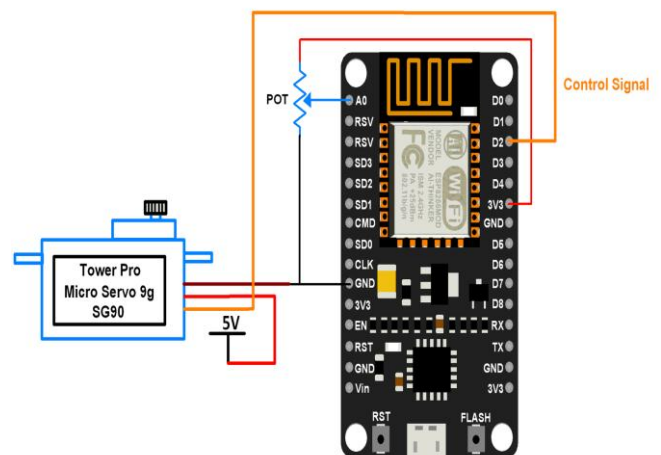

Fig : Interfacing Esp12 with Servo motor

3. SYSTEM ARCHITECTURE

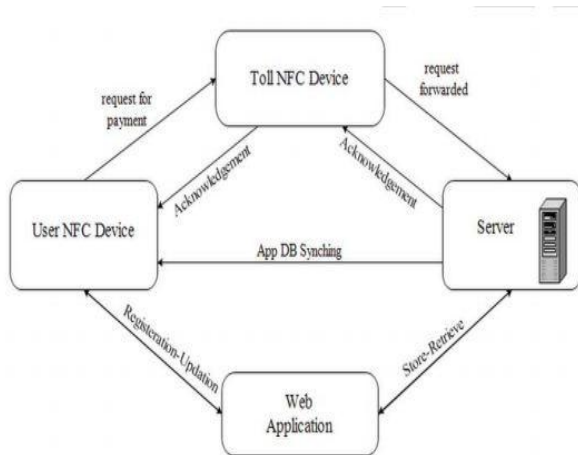
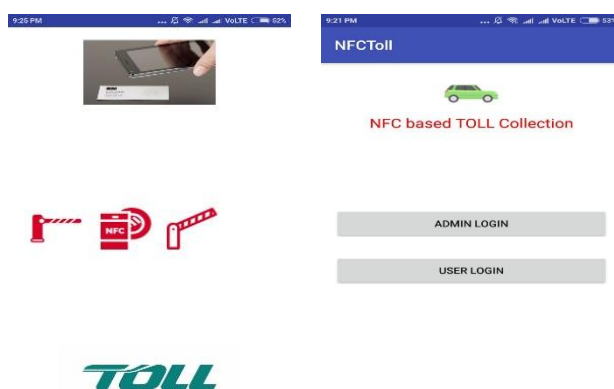

Fig. 3.1: System Architecture

The block diagram mainly consists of four components those are user NFC card, Toll NFC device, Server and presented web Application. The web application is hosted for purpose so that the admin can update the balance if low. Initially user can register his details and an NFC card is issued to him. Android app available in his device may be used to check history from which toll his car has passed. During the registration process, client/user will be provided with the NFC-Id that will be unique as per user's filled details. The whole required details will be saved into user's respective account database (Server).

4. DESIGNED SYSTEM

When we start the application an animation of toll gate opening is displayed



The first page is to select between "Admin Login" and "User Login"

The User Login allows two options of "Register New Car" and "Tap to Toll"

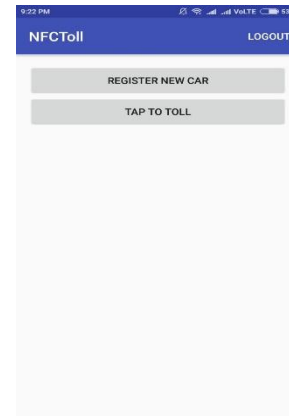

User Login and admin login page are shown below

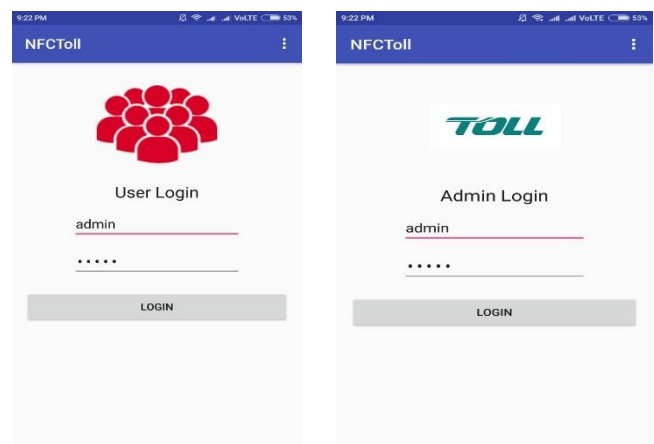

In user login the history is shown from which all toll booths the car have passed and how much amount is deducted.

Information like time and date at the toll booth is saved in history so that user can have a look at it whenever he wants to.

5. CONCLUSION

In this paper, from the above research and ways of doing things used we figure out that the system provides a paperless passage for toll gate with fully automated toll collection. That's the reason for the thought about/believed system provides a smart solution to the usual & toll collection method. This way the system (accomplishes or gains with effort) performance factor as better user convenience from payment without stops, less traffic jam, better audit control and clearness/open honesty at toll transaction. The only disadvantage is internet connection is necessary.

ACKNOWLEDGEMENT

We sincerely wish to thank our project guide Prof. Swapnil Gholap for her ever encouraging and inspiring guidance helped us to make our project a success. Our

project guide made us endure with her expert guidance, kind advice and timely motivation which helped us to determine about our project

We also express our deepest thanks to our Head of our Computer Department Prof. P. R. Rodge and project coordinator Prof. Uttara Gogate whose benevolent helps us making available the computer facilities to us for our project in our laboratory and making it true success. Without his kind and keen co-operation our project would have been stifled to standstill

Lastly, we would like to thank our college principal Dr. J. W. Bakal for providing lab faculties and permitting us to go on with our project. We would also like to thank our colleagues who helped us directly or indirectly during our project.

REFERENCES

- [1] Guo-Huang Hsu, Liang-Rui Lin, Rong-Hong Jan, and Chien Chen ,” Design of ETC Violation Enforcement System for Non-payment Vehicle Searching”, ICACT Transactions on Advanced Communications Technology (TACT) Vol. 2, Issue 1, March 2013
- [2] Saijie Lu, Tiejun He, Zhaohui Gao,” Design of Electronic Toll Collection System based on Global Positioning System Technique”, 2009 ISECS International Colloquium on Computing, Communication, Control, and Management 978-1-4244-4246-1/09/\$25.00 ©2009 IEEE CCCM.
- [3] Z. Feng, Y. Zhu, P. Xue and M. Li, “Design and realization of expressway vehicle path recognition and ETC system based on RFID,” 3rd IEEE International Conference on Computer Science and Information Technology (ICCSIT),vol. 7, pp.S6- 90, 2010.
- [4] Z. Feng, Y. Zhu, P. Xue and M. Li, “Design and realization of expressway vehicle path recognition and ETC system based on RFID,” 3rd IEEE International Conference on Computer Science and Information Technology (ICCSIT),vol. 7, pp.S6- 90, 2010.
- [5] Saijie Lu, Tiejun He, Zhaohui Gao,” Design of Electronic Toll Collection System based on Global Positioning System Technique”, 2009 ISECS International Colloquium on Computing, Communication, Control, and Management 978-1-4244-4246- 1/09/\$25.00 ©2009 IEEE CCCM