

# Enhancement of Marine Data Network Using IOT

<sup>1</sup>POOJA GUNDEWAR, <sup>2</sup>AKSHAY JADHAVAR, <sup>3</sup>DIVYA JAGTAP, <sup>4</sup>RUPALI DESHMUKH,  
<sup>5</sup>SAVITA JADHAV

<sup>1,2,3</sup> Student, Dept of E&TC, DIT, Pimpri,

<sup>4,5</sup> Assi. Prof., DIT, Pimpri.

\*\*\*

**Abstract** – This paper deals with an investigation of the motion of ships, avoidance of maritime accidents and incidents, such as ship collision with obstacles, fuel leakage, fire explosion.

The occurrence of the accidents place port in a very dangerous situation, since the port could suffer from a high risk of blockage of port entry, and the consequent economic loss can be substantial.

In the case of maritime accidents, a client will connect to the server using TCP/IP link. Once a client connects to the server, client can issue commands to move the ships in forward, backward, right and left direction.

**Key Words:** TCP/IP Protocol link, ultrasonic sensor, fuel leakage sensor, fire sensor, Wi-Fi, android phone, Internet of Things (IOT).

## 1. INTRODUCTION

In this project there will be client and server communication. A ship model will be a server and a mobile phone shall behave link a client. A server needs to have public IP which has to be recognized uniquely. A client can connect any android phone with a client output. A client will connect to a server using TCP/IP protocol link. Once a client connect to the server, client can issue the commands like to move the ship in forward, backward, right and left direction. The precious information link current location (latitude, longitude) of the ship and the other information link like fuel leakage, fire information can also be obtained. In this project we are going to detect the obstacles coming in the path of ship by using ultrasonic sensor.

### 1.1 Working Principle

#### 1.1.1 Tilt measurement

Three axis accelerometer measures the tilt angle and displays on the LCD and also we can measure the angle of deviation of ship.

#### 1.1.2 Fuel Leakage Detection

Gas Sensor (MQ5) module is useful for gas leakage detection. It is suitable for detecting H<sub>2</sub>, LPG, CH<sub>4</sub>, CO, Alcohol. Due to its high sensitivity and fast response time, measurements can be taken as soon as possible. The sensitivity of the

sensor can be adjusted by using the potentiometer. The output voltage from the Gas sensor increases when the concentration of gas increases.

#### 1.1.3 Fire Detection

The LM35 series are precision integrated-circuit temperature sensors, whose output voltage is linearly proportional to the Celsius (Centigrade) temperature. The LM35 operates at -55° to +120°C. For 1 degree Celsius temperature there is change of 10 mV in output voltage.

#### 1.1.4 Obstacle Detection

Obstacles are detected which are coming in the path of ship. Ultrasonic sensors emit short, high-frequency sound pulses at regular intervals. If they strike an object, they are reflected back as echo signals to the sensor, which itself computes the distance to the target based on the time-span between emitting the signal and receiving the echo.

#### 1.1.5 Location tracking using GPS

GPS or Global Positioning System is a satellite navigation system that furnishes location of ships. GPS provides continuous real time, 3-dimensional positioning, navigation and timing worldwide.

It tracks the current location of ships and send it to microcontroller.

#### 1.1.6 Providing commands through Android phones

Android phone will connect to the server using TCP/IP link. Once it connects to the server, it can issue commands to move the ship in forward, backward, left and right direction by using Wi-Fi serial application.

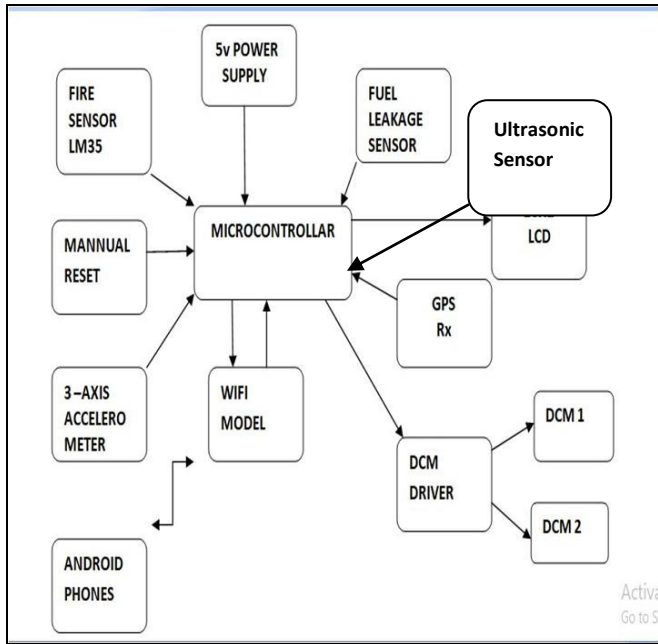
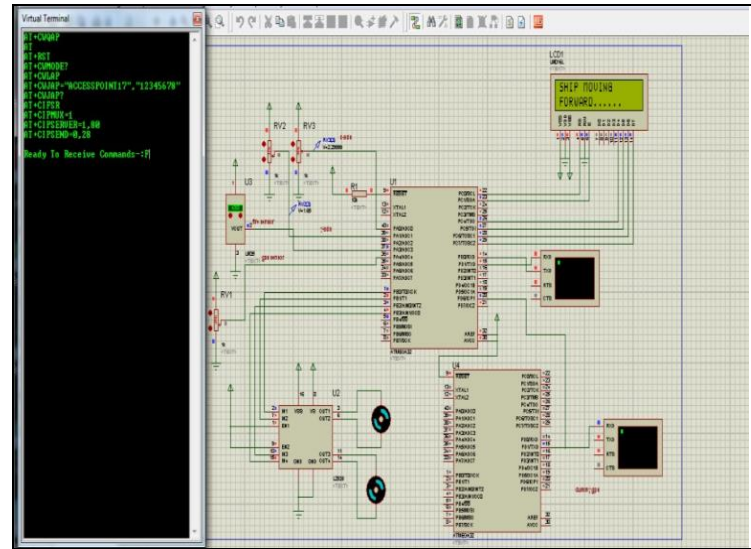

Fig -1: Block Diagram

### 3. RESULT



### 4. CONCLUSION

Due to high cost of other available technologies, the demand for data networks in the marine environment for safety and convenience has increased. In this paper, implementation IOT data networks in marine environment has been shown using Wi-Fi infrastructure available on ships and android phones.

### 5. FUTURE SCOPE

The technology can be improved further by giving commands using satellites communication.

### REFERENCES

1. B. Hui, K. Jeon, K. Chang, S. Kim, J. Park, and Y. Lim, "Design of radio transmission technologies for vhf band ship ad-hoc network", in ICT Convergence(ICTC), International conference on. IEEE, 2011, pp.626-629.
2. R.J.Mohsin, J.Woods and M.Q.Shawkat, "Density and mobility impact on manet routing protocol in maritime environment", in Computer Science And Information Conference(SAI), 2015.IEEE, 2015, pp 1046-1051.
3. Rabab Al-Zaidi, J.Woods and Mohammed Al-Khalidi, "Next Generatin Marine Data Network In An IOT Environment", Second International Conference On Fog And Mobile Edge Computing (FMEC), 2017.IEEE, 2017, pp 50-55.
4. R. Mohsin and J. Woods, "Performance evaluation of manet routing protocols in a maritime environment," in Computer Science and Electronic Engineering Conference (CEEC), 2014 6th. IEEE, 2014, pp. 1-5.
5. M. Rabab J., W. John, and M. Q. Shawkat, "(amdc) algorithm for wireless sensor networks in the marine environment," International Journal of Advanced Computer Science and Applications(IJACSA), vol. 6, no. 6, 2015.

### 2. FLOWCHART

