

# CFD ANALYSIS OF DOUBLE PIPE HEAT EXCHANGER WITH DIFFERENT INNER SECTIONS

Hariraam.V<sup>1</sup>, Domnic Edward.D<sup>2</sup>, Gokula Krishnan.M<sup>3</sup>, Dombega Shivajittu<sup>4</sup>, Selvan.P<sup>5</sup>

<sup>1,2,3,4</sup> Student of B.E Mechanical Engineering, SNS College of Engineering, Coimbatore, India

<sup>5</sup> Under the Guidance of Assistant Professor, Department of Mechanical Engineering, SNS College of Engineering, Coimbatore, India

\*\*\*

**Abstract** - Heat transfer techniques and thermal properties of Heat Exchanger can be analyzed using Computational Fluid Dynamics tools. There exists no analysis with varying the inner section, tube of double piped heat exchanger with square as a substitute for conventional circular section. The methodology for CFD analysis of a heat exchanger is validated is the effect of fluid properties for both square and circle sections are with constant temperature and thermal properties where analyzed. The contour of temperature for both the circular and square sections are calculated using ANSYS fluent 15.0, Where the equation of mass, moment and heat transfer where solved simultaneously using k- epsilon two equation turbulence mode. Thus, this research results in better selection of inner section for double pipe heat exchanger.

**Key Words:** Heat Exchanger, Computational Fluid Dynamics, Varying Inner Sections, Circle, Square.

## 1. INTRODUCTION

Heat exchanger plays an important in power plants and heat recovery units. Due to increasing the population, the energy is efficient for our daily works. So that many heat exchangers can be used for utilize the energy efficiently. Here analyzing the heat transfer between two fluids such as hot and cold. In this paper the circle and square shape of heat exchanger pipe was analyzed for which one is maximum heat transfer rate. The analysis is done by the computational fluid dynamics in the software of ANSYS fluent 15.0. The flow analysis is set between hot and cold water passing the pipe. The velocity of hot water is less when compared to the cold water in order to increase the heat transfer rate. The heat transfer coefficient is critical for designing and developing the flow of process.

### 1.1 Types of Heat Exchanger

There are innumerable types of heat exchangers are available in use such as Tubular type heat exchanger, Plate type heat exchanger, Extended heat exchanger, Regenerative heat exchanger. Here the Tubular type Double Pipe Heat Exchanger is analyzed.

## 2. INPUT PARAMETERS

### 2.1 Double pipe Heat Exchanger with Inner Circular Section

#### 2.1.1. Calculation for Inner Circular Section

Diameter, d	= 0.06m
Area, a	= $(\pi d^2)/4$ = $2.82 \times 10^{-3} \text{ m}^2$
Velocity, v	= 0.003m/s
Hydraulic diameter, H <sub>d</sub>	= $(4A/P)$ = 0.06m
Mass flow rate, m	= $\rho.A.V$ = 0.01 kg/s

#### 2.1.2. Calculation for outer section – Cylinder

Area, A	= $7.4612 \times 10^{-3} \text{ m}^2$
Velocity, V	= 0.004m/s
Mass flow rate, m	= $\rho.A.V$ = 0.029Kg/s

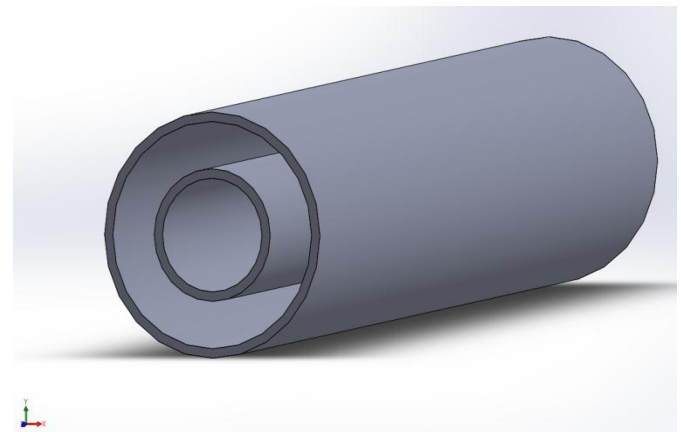

**Fig-1:** Solid Model of Double pipe Heat Exchanger with inner Circular Tube modeled using SOLIDWORKS

### 2.2. Double pipe Heat Exchanger with Inner Square Section

#### 2.2.1 Calculation for Inner Section Square:

Hydraulic Diameter, D <sub>h</sub>	= 0.06m
Area, A	= a <sup>2</sup>

Perimeter, Side, a  $P = 4a$   
 $0.06 = (4A/P)$   
 $0.06 = (4 \times a^2)/4a$   
 $a = 0.06m$   
 Mass flow rate, m  $= \rho.A.V$   
 $= 0.0108 \text{ Kg/s}$

**2.2.2 Calculation for Outer section – Cylinder**

Area, A  $= 6.409 \times 10^{-3} \text{ m}^2$   
 Velocity, V  $= 0.004m/s$   
 Mass flow rate, m  $= \rho.A.V$   
 $= 0.0256 \text{ Kg/s}$

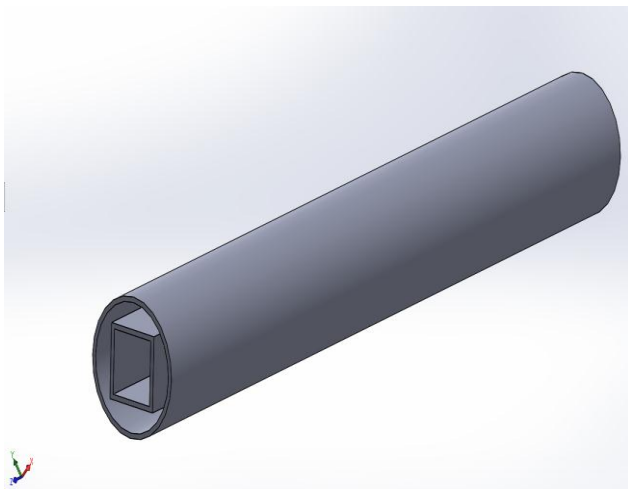

**Fig-2:** Solid Model of Double pipe Heat Exchanger with inner Square Tube modeled using SOLIDWORKS.

**3. SOLUTION STRATEGY & CONVERGENCE**

The mesh made is with small mesh sizes, so good gradients can be obtained in boundaries. The values in the table indicate the properties of circular, Square inner pipe.

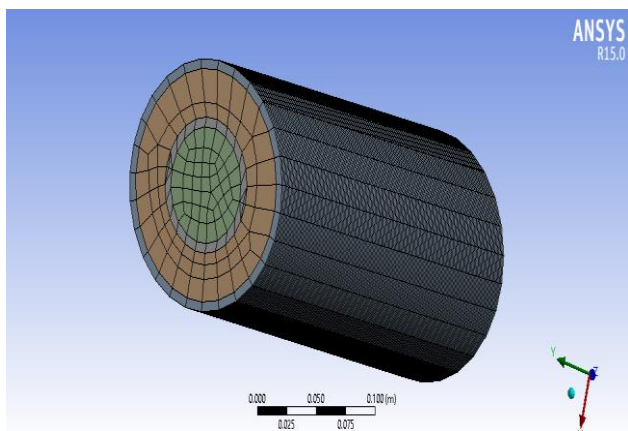

**Fig-3:** Double pipe Heat Exchanger Circular Tube with Mesh

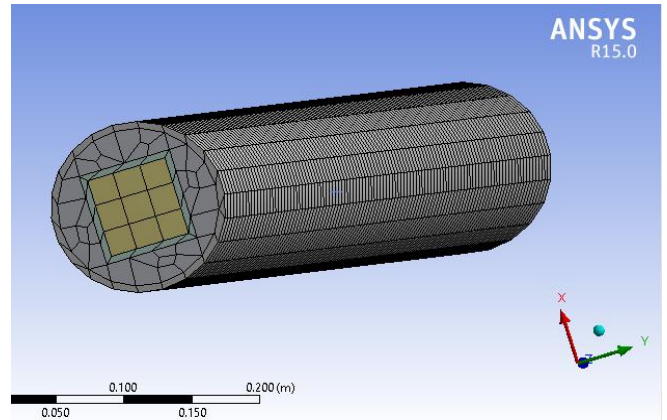

**Fig - 4:** Double pipe Heat Exchanger Square Tube with Mesh

**Table - 1:** Details of Mesh Model

Details	Circular Section	Square Section
Nodes	33425	9900
Element	31350	9047

**4. VALIDATION OF MODEL**

The circular and square tube was analysed using computational fluid dynamics for counter flow where hot fluid flows through the inner pipe and the cold fluid flows through the outer pipe. Heat transfer parameters, such as temperature drop was calculated. Thus simulation results were developed. The simulation results of the circular tube were compared with the results obtained for a square tube of equal length and similar operating conditions in order to compare its performance related to thermal properties of the heat exchangers.

**Table - 2:** CFD Validation Parameters

Type of Inner Section	CIRCLE	SQUARE
Length	1m	1m
Hydraulic Diameter	0.06m	0.06m
Working Fluid	WATER LIQUID	WATER LIQUID
Cold Fluid Inlet Temperature	303 K	303 K
Hot Fluid Inlet Temperature	350 K	350 K
Mass Flow Rate	0.01 Kg/s	0.0108 Kg/s

### 5. RESULT

CFD computations were done for the mass flow rate of water 0.01 circular tube and 0.0108 kg/s for square tube. Performance parameters adopted for comparison are heat pick range by the cold fluid and heat flow rate.

The heat transfer in the circular tube in analysed in ANSYS FLUENT as fig- 5 and the results fig - 6 are obtained.

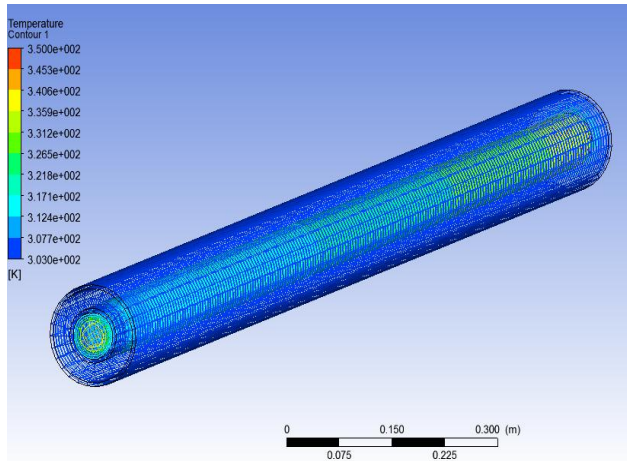

Fig - 5: Temperature Contour of Circular tube

Average of Facet Values Static Temperature		(k)
cold_inlet		303
cold_outlet		314.27319
hot_inlet		350
hot_outlet		331.73666
<b>Net</b>		<b>322.40833</b>

Fig - 6: Results of Static Temperature

The heat transfer in the square tube in analysed in ANSYS FLUENT as fig 7 and the results fig 8 are obtained.

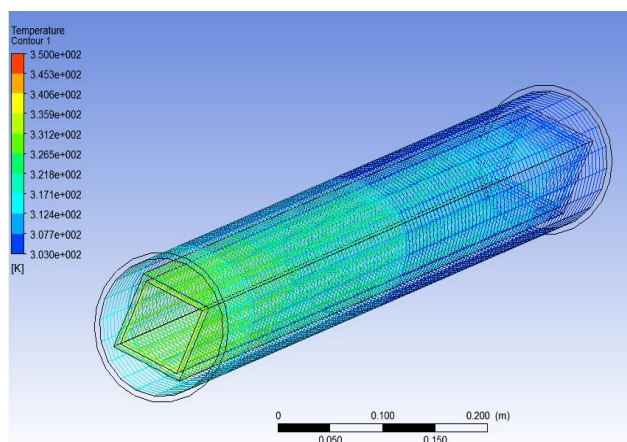

Fig -7: Temperature Contour of Square tube

Average of Facet Values Static Temperature		(k)
cold_inlet		303
cold_outlet		316.78024
hot_inlet		350
hot_outlet		333.09152
<b>Net</b>		<b>316.22125</b>

Fig - 8: Results of Static Temperature

Table - 3: Comparison of Working Fluid Temperature

Type of Inner Section	Circle	Square
Cold Fluid inlet Temperature	303 K	303 K
Cold Fluid outlet Temperature	314.27 K	316.78 K
HotFluid inlet Temperature	350 K	350 K
Cold Fluid outlet Temperature	331.73 K	333.09 K
Heat Flow rate ,Q	1366.808 W	1475.274 W

From the results, the cold fluid outlet temperature is higher in square tube than the conventional circular tube. Thus, the Heat absorbed by the cold fluid from the hot fluid is more in square tube than the conventional circular tube.

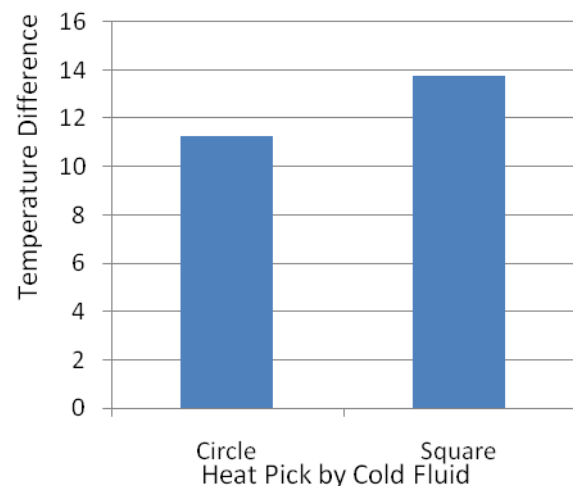
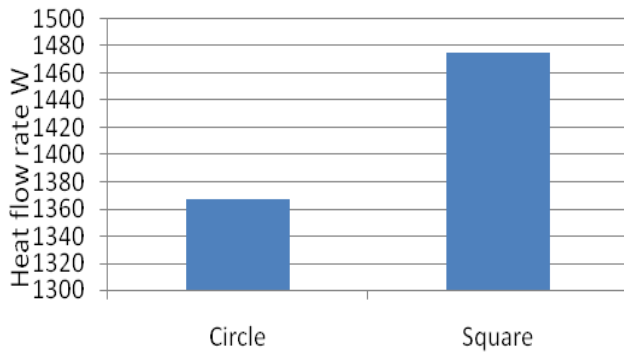

Chart - 1: Temperature Difference of Cold Fluid (Heat pick up range) in different inner sections.

The heat flow rate of cold fluid for circle tube is 1366.80W

The heat flow rate of hot fluid for square tube is 1475.27W.

The heat flow rate of cold fluid for circle tube and square tube is plotted as a graph shows in the Chart 2.



**Chart - 2:** Heat Flow Rate of Cold Fluid in different inner sections

## 6. CONCLUSION

Comparing with the circular and square, the heat pick rate in the cold fluid done by the square section is more in the counter flow. The heat flow rate is high due to high end turbulent edges are more when compared to circle. The CFD software have emerged as a cost effective and speedy solution provider to heat exchanger design, analysis and optimization. In square corners were present while the circle has no corners, When the number of corners increases the heat dissipation at the corners are also increases. So the net heat flow rate also increases.

## REFERENCES

1. Muhammad Mahmood Aslam Bhutta et al, CFD applications in various heat exchangers design: A review, Applied Thermal Engineering, 32 (2012), Page No.1-12.
2. M.Z.M.Saqheeb Ali et al, Thermal Analysis of Double Pipe Heat Exchanger by Changing the Materials Using CFD, International Journal of Engineering Trends and Technology (IJETT) - Volume 26 Number 2- August 2015 Page no. 95-102
3. Kale Shivam B et al, Experimental analysis & Simulation of double pipe heat Exchanger, IJARIIIE-ISSN(O)-2395-4396, Vol-3 Issue-2 2017 I
4. Dr.Y.Krishna et al, CFD Analysis and Performance of Parallel and counter flow in Concentric tube heat Exchanger, International Journal of Engineering Technology and research Vol-2, Issue -11, November 2017, Page No. 2782-2792.