

PLC based bottle filling with automatic volume detection

Pradnya Babar¹, Sheetal Marab², Urmila Gatkul³

^{1,2} Students, dept. of Electronics and Telecommunication, SVERI's College of Engineering Pandharpur, Maharashtra, India.

³ Professor, dept. of Electronics and Telecommunication, SVERI's College of Engineering Pandharpur, Maharashtra, India.

Abstract - Our project is based on the industrial automation. This project is used in many industries like mineral water, milk industries where the filling process is carried out. In this project the bottle is placed on the conveyor belt and one bottle at a time is filled. In this process two different size of bottle. The wastage of water is prevented by this method.

The entire process of filling of various sizes of bottles and automatic detection of volume of bottle is carried out with the help of PLC.

Key Words: PLC, IR sensor, Conveyor belt, solenoid valve.

1. INTRODUCTION

PLC plays a lead role in the world of automation. PLC is reliable and hence provides accurate output. In our project, the filling operation is done through PLC which allows filling of the liquid to a desired level. It also reduces wastage of liquid. Ladder logic is one of the methods used for programming PLC. Logic is developed and according to that the filling operation takes place. The PLC used is Allen Bradley. Automation is used in our day to day life for example in the field of control system, information technologies, etc. Automation reduces the human work and efforts. The world's economy is very much helped by the PLC automation.

2. METHODOLOGY

A conveyor belt is used on which the bottles are placed. The position of the bottle is sensed through IR sensor. IR sensor gives output as logic '1' or logic '0' and depending upon its output corresponding motor turns ON. The filling operation is done with automatic detection of volume of bottle and selection the amount of liquid to fill the bottle. The filling process is done based on timing. Timer is used for defining the time according to that the preset value is set and depending on the preset value the pump is switched ON.

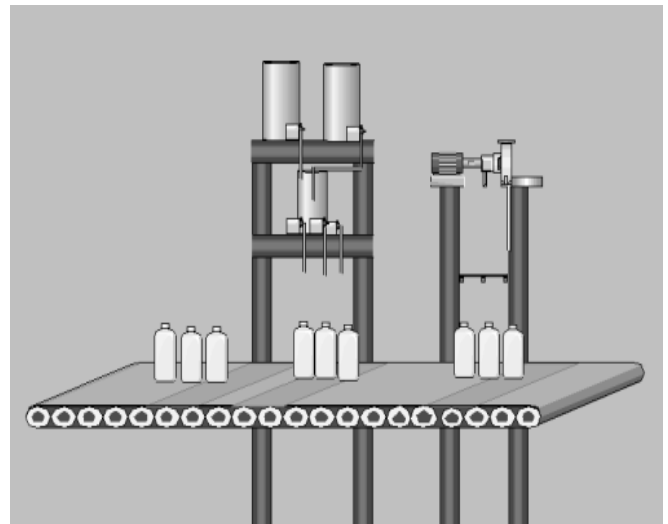

Figure (1). Overview of Bottle filling plant

3. BLOCK DIAGRAM

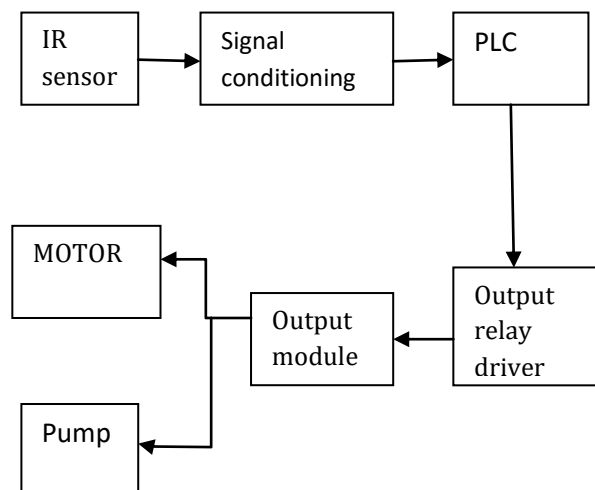

Figure (2). Block diagram

3.1 WORKING:

INPUT MODULE:

The input module includes IR sensors. There are three IR sensors one is used to detect the position of the bottle on the conveyor belt and two pairs of IR sensor are used to

detecting the volume and also for detecting the position of the bottle for filling process. The input of conveyor belt where the bottles are fed the first IR sensor is placed. This sensor is used to detect the proper position on the conveyor. The other two pairs are kept at the filling operation to detect the proper position for filling operation and simultaneously for detecting the volume. These sensors also help to stop the conveyor. Hence inputs are given to input module.

SIGNAL CONDITIONING:

The output of the IR sensor is low approximately 5v. For PLC we require input should be 24v. Hence for this purpose we use signal conditioning circuit which condition the input signal and increases it and can be given to PLC as a input. The output of PLC is given to the output devices like motor etc. through relay circuit. The relay has three terminals they are common, NC and NO.

PLC:

PLC is a specialized computer used to control machine and process. Plc consists of I/O unit, memory unit, CPU. The I/O unit interacts with the user. It requires 24v of input. The ladder logic is one of the method used for programming of PLC. The process of bottle filling is done with the help of PLC. Depending on the logic developed the entire filling operation for various sizes of bottle is carried out. Hence all processing and control operation is done through PLC.

OUTPUT RELAY DRIVE UNITL:

The operating voltage required for output device like motor is nearly about 12v and the output of the PLC is about 24v. In order to drive the output devices we give the output of PLC through a relay driver circuit to the output devices.

OUTPUT MODULE:

DC motor and pump are the output devices used for the bottle filling process. These are connected to the output module. The DC motor is used to run the conveyor in forward direction. There is one pump used for the filling process. These are the output devices used in the bottle filling process. This is shown in above block diagram.

4. FLOW CHART:

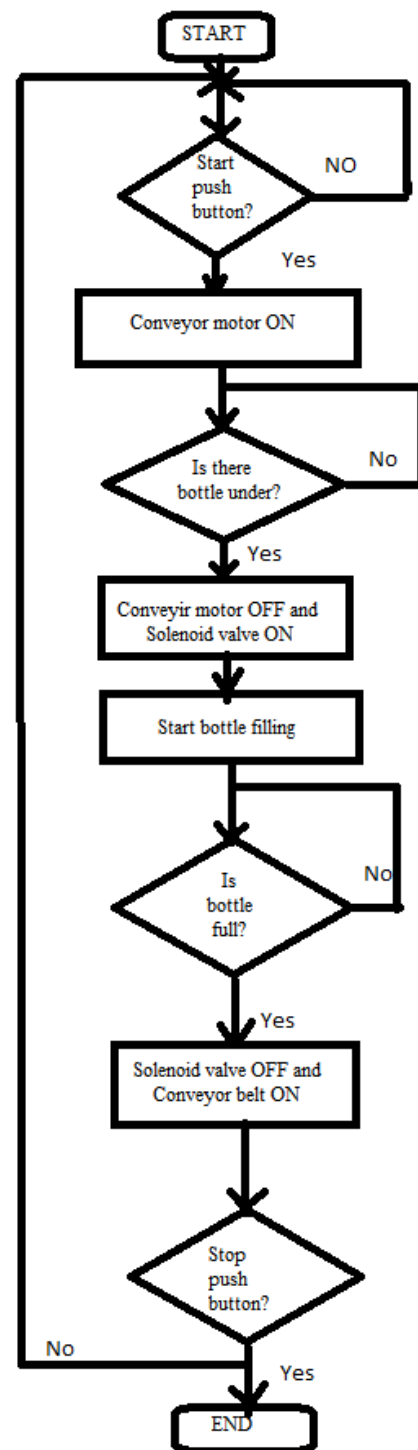

CONCLUSION

The purpose of this project is to fill the bottle to a desired level using PLC. To bring the economic progress and increase the productivity we use automation systems. The whole system is controlled with the help of PLC. The system is reliable, flexible, time saving.

REFERENCES

- [1] T. Kalaiselvi, R.Praveena, Aakanksha. Dhanya, "PLC Based Automatic Bottle Filling and Capping System" With User Defined Volume Selection, International Journal of Emerging Technology and Advanced Engineering August 2012.
- [2] Anup Dakre, Junaid G. Sayed , Ekata A. Thorat , Aousaf Ahamad Md. Aves Chaudhary, "Implementation of Bottle Filing and Capping using PLC".
- [3] Vinod Jiddi, Automatic Liquid Filling using PLC, International Journal of Recent Advancement in Engineering & Research 2017.