

# Review paper on Stator and Rotor Fault Diagnosis Of 3-Phase Induction Motors

<sup>1</sup>Yogesh R. Patni, <sup>2</sup>Prof. M.M.Ansari

<sup>1</sup>PG Student, SSBT Bambhori, Jalgaon

<sup>2</sup>Asst. Professor, SSBT Bambhori, Jalgaon

\*\*\*

**Abstract** – I.M. are widely used in almost every other field dealing with electrical power such as industrial engineering mechanical and manufacturing field. Induction motors are simple, efficient and most rugged thus with a very high reliability. But like any other motor, they are vulnerable to faults, which if not considered, may result in catastrophic failure of the motor in the continuous operation. Condition monitoring of the induction motors has been widely used in the detection of faults. In this paper the various faults and study of conventional and innovative techniques for induction motor faults.

This paper presents a detailed analysis of methods to detect induction motor faults and proposes future research areas. Systematic approaches must be exploited to predict incipient machine faults.

**Key Words:** ANN, Computer Simulation, Data Acquisition, Fast Fourier Transforms, Fault Diagnosis, Fuzzy Logic, Induction Motors, Parameter Estimation, Vibration Measurement, Wavelet Transforms

## 1. INTRODUCTION

Induction motors are the important for every industry. However as in any other machine, they will eventually fail because of heavy operating duty, poor working environment, improper installation and manufacturing factors, etc. With escalating demands for reliability and efficiency, the field of fault diagnosis in induction motors is gaining importance. If the faults are not prognosticated beforehand, it may result in large revenue losses as well as pose threat to reliability and safety of operation. However, many methods have been proposed for fault detection and diagnosis, but most of the methods require a good deal of expertise to apply them successfully. Simpler approaches are needed to enable even amateurish operators with nominal knowledge of the system to scan the fault condition and make reliable decisions.

The induction motor is subjected to primary types of fault and related secondary faults. Fig.1 (a) classifies the sources of induction motor faults. In Fig. 1(b), the internal fault tree is depicted and Fig. 1(c) illustrates the external fault tree for an induction motor. Broadly, an induction motor can develop either internal fault or external fault. With reference to the origin, a fault may be mechanical or electrical. Fault can be classified as stator fault or rotor fault depending on the location of the fault. Faults associated with the moving parts like bearing and cooling faults are categorized as rotor faults [1]. Specifically, induction motor faults can be broadly classified into bearing failures, stator faults, rotor faults, air gap eccentricity, mechanical vibrations, etc. Fig.2 illustrates the relative probability of occurrences of various faults in an induction machine [2].

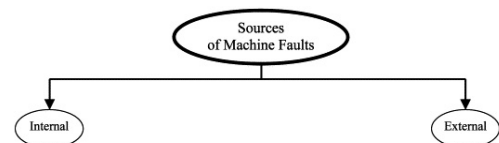

Figure 1(a): Sources of Machine Faults

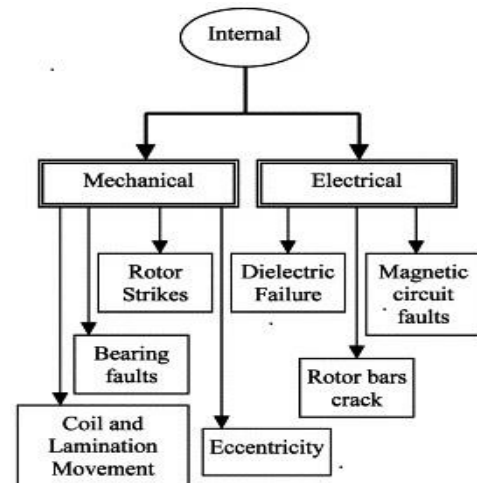

Fig. 1(b) Block Diagram Presentation of Internal Faults

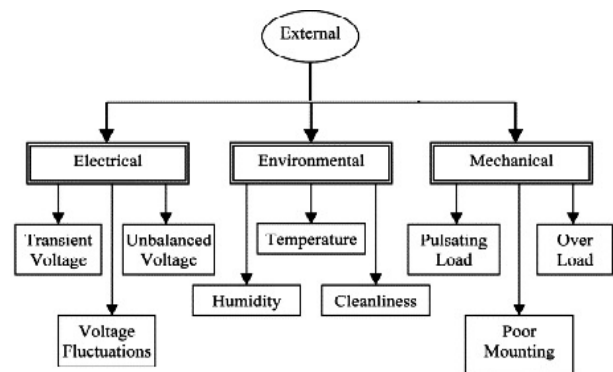

Fig. 1(c) Block Diagram Representation of External Faults

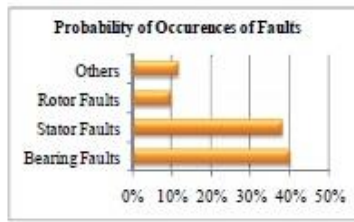

Fig.2. Faults by % in an Induction Motor

A typical diagnosis system [3] shown in Fig. 3 consists of a sensor assembly which provides the fault signal to a signal processing unit, which further sends its result to be analyzed by expert systems, where the corresponding fault is ultimately detected.

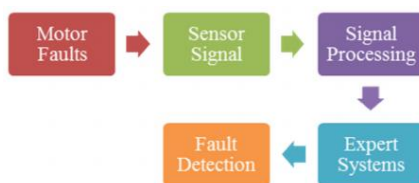

Fig. 3. On-Line Fault Monitoring of Induction Motor

Condition monitoring and fault diagnostics are usually implemented by investigating the corresponding anomalies in machine current, voltage and leakage flux. Other methods[4] including monitoring the core temperature, bearing vibration level and pyrolyzed products, have been reported to diagnose fault conditions such as insulation defects, partial discharge and lubrication oil and bearing degradation. Numerous induction motor fault techniques are based on Fast Fourier Transform Spectral Signature analysis, vibration analysis, temperature measurements, harmonic analysis of speed fluctuations, state or parameters estimation, either axial flux or air gap torque analysis, acoustic noise arrangement, magnetic field analysis, fuzzy logic and neural networks, etc.

## 2. INDUCTION MOTOR FAULTS:

Profound efforts have been devoted to Induction motor fault diagnosis. Depending on the region of fault occurrence, induction motor faults are mainly put under the following five categories.

### 2.1. Bearing Faults

Generally, a rolling-element bearing is an arrangement of two concentric rings. A set of balls or rollers spin in raceways between the inner ring and outer ring. Bearing defects may be categorized as “distributed” or “local”. Distributed defects include misaligned races, waviness, surface roughness and off-size rolling elements. Localized defects include spalls, pits and cracks on the rolling surfaces. These localized defects create a series of impact vibrations at the instant when a running roller passes over the surface of a defect whose period and amplitude are calculated by the

anomaly’s position, speed and bearing dimension. Mechanical vibrations are produced by the flawed bearings. These vibrations are at the rotational speed of every component. The bearing dimensions and the rotational speed of the machine are used to determine the characteristic frequencies associated to the raceways and the balls or rollers. The condition of the bearing is ascertained by examining these frequencies. This task is accomplished using mechanical vibration analysis techniques.

### 2.1. Stator Faults

An induction motor is subjected to various stresses like thermal, electrical, mechanical, and environmental. Most stator faults can be attributed to such stressful operating conditions. Faults in the stator winding such as turn-to-turn, coil-to-coil, open circuit, phase-to-phase and coil-to-ground, are some of the more prevalent and potentially destructive faults. If left undetected, these may eventually cause cataclysmic failure of the motor. The three main divisions discussed in of stator faults are the following.

#### a) Frame :

- Vibration
- Circulating currents
- Earth faults
- Loss of coolants

#### b) Lamination:

- Core slackening
- Core hot spot

#### c) Stator windings faults:

- End winding portion (turn-to-turn faults, fretting of insulation, local damage to insulation, damage to connectors, discharge erosion of insulation, displacement of conductors, contamination of insulation by moisture, oil or dirt, cracking of insulation and so forth).
- Slot portion (insulation fretting, displacement of conductors).

### 2.3. Rotor Faults

Rotor faults can be induced by electrical failures such as a bar defect or bar breakage or mechanical failures such as rotor eccentricity. The first fault occurs from thermal stresses, hotspots, or fatigue stresses during transient operations such as start-up, especially in large motors. A broken bar changes torque significantly and became dangerous to the safety and consistent operation of electric machines. The second type of rotor fault is related to air gap eccentricity. This fault is a common effect related to a range of mechanical problems in induction motors such as load unbalance or shaft misalignment. Long-term load unbalance can damage the bearings and the bearing housing and

influence air gap symmetry. Shaft misalignment means horizontal, vertical or radial misalignment between a shaft and its coupled load. With shaft misalignment, the rotor will be displaced from its normal position because of a constant radial force.

### 2.4. Eccentricity Faults

Unequal air gap between stator and rotor results in eccentricity of induction motor. In general, air-gap eccentricity can be of two types: the static air-gap eccentricity and the dynamic air-gap eccentricity. A mixture of both forms, called mixed eccentricity and the axial non uniformity of air gap, known as inclined eccentricity have also been accounted. The minimal radial air-gap length is fixed in space for static air-gap eccentricity. On the contrary, the center of rotor and the center of rotation do not coincide for dynamic eccentricity. In this case, the position of minimum air gap is not fixed in space but rotates with the rotor. An erroneous positioning of the rotor or stator during the commissioning phase may give rise to static eccentricity. It may also be caused by stator core ovality. A cause of dynamic eccentricity can be a bent shaft, bearing wear and movement, or mechanical resonances at critical speeds.

### 2.5. Vibration Faults

Vibrations are natural processes in induction motors which are caused by the oscillations of mechanical parts of the motors. These oscillations are reflected in the external system attached with the machine shaft. Consequently, machine related frequency spectrum is generated which is unique for a healthy motor. Each fault in the motor changes the frequency component of the spectrum. This can be compared with the reference spectrum to perform fault detection and diagnosis.

## 3. FAULT DIAGNOSIS

The spectrum of supply current of an induction motor can be analyzed for the diagnosis of faults appearing in it. For a healthy motor, there will be no existence of backward rotating field and only the forward rotating magnetic field rotates at synchronous speed. In the occurrence of any fault, there will be a resultant backward rotating field in the air gap and the spectrum of stator current will change. In Table 1 various frequency components introduced in supply current spectrum due to faults has been summarized. By monitoring the various frequencies in Table 1, it is possible to diagnose the corresponding motor faults. Nevertheless, it has been observed that these frequency components cannot be treated as exact signs of occurrence of motor faults as these frequencies can be detected in the spectrum of even healthy motors due to unavoidable manufacturing symmetries and misalignment etc., Many techniques have been proposed and developed over years that provide a good measure of occurrence of faults in induction motors.

Faults	Frequency
	$f_{sl} =  f_s \pm n f_r $
Bearing Fault	$f_{bc} = \frac{N_b f_r}{2} \left[ 1 \pm \frac{D_b}{D_p} \cos \theta \right]$
Rotor Fault	$f_{br} = f_s \left[ n \frac{(1-s)}{p} \pm s \right]$
Eccentricity	$f_m = f_s \left[ (n R_s \pm O_m) \frac{(1-s)}{p} \pm O_{sm} \right]$

**Table 1. Frequency Components of Induction Motor Faults**

fcfb	components generated by bearing faults
fs	supply frequency
n	1,2,3... [Integral values]
frc	characteristics race frequencies
Nb	number of bearing balls
Db	ball diameter
Dp	bearing pitch diameter
θ	contact angle of the ball on the races
fcbrf	components generated by broken rotor faults
p	number of pole-pairs
s	per-unit slip
Ore	components associated with eccentricity
Osmh	rotating eccentricity order stator MMF harmonic order
Rs	number of rotor slots

### 3.1. Detection of Bearing Faults

#### 3.1.1. Vibration Spectrum Analysis

To extract from a time domain signal the frequency domain representation. The forces occurring in the rolling element bearing in electrical machines create high frequency components of vibration. During normal conditions, these high frequency components are mainly because of friction but in case of a defect in bearings shock pulses can also be found due to breaks in lubrication layer between the friction surfaces. This method analyses the vibration spectrum of an induction machine using piezoelectric accelerometer which works on Fast Fourier Transform, For instance, a 0.75 kW induction motor with 6202 ball bearing type having number of balls N= 8, is taken for experimentation. The harmonic vibration spectrum of the healthy motor and that with defective bearing is analyzed individually. Fig. 4(a) and Fig. 4(b) portray the vibration amplitudes for the analyzed frequencies, f1=100Hz, f2=152Hz, rotational frequency f= fr =50Hz and sideband 150-300Hz, for the motor with healthy bearing and defective bearing respectively. The vibration amplitude for faulty motor is bigger than that of a healthy motor.

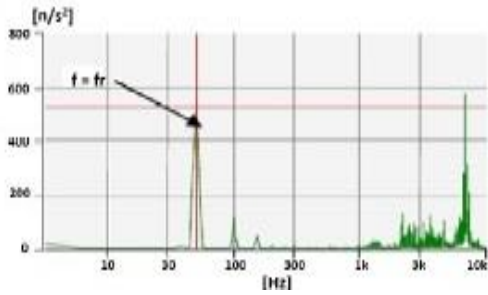

Fig. 4(a). Harmonic Vibration Spectra of Induction Motor with Good Bearing

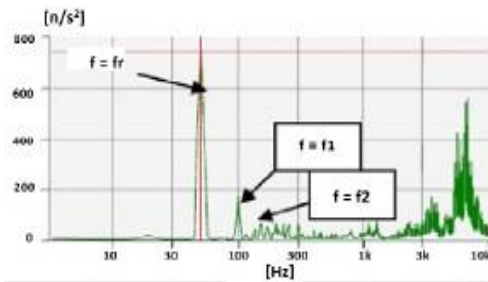

Fig. 4(b). Harmonic Vibration Spectra of Induction Motor with Bad Bearing

The dynamic simulation of a motor running with faults in the bearing inner race is presented and a winding function approach is applied to the model of an induction motor with mixed eccentricities due to inner race faults. A spectral analysis of electromagnetic torque developed by the simulated motor is compared with those of vibrations resulting from experiments on motor with faulty bearing. Fig. 5(a) and Fig. 5(b) elaborate the power spectral density and analysis of vibration signal in frequency domain. The spectrum magnitude is then standardized to have a bandwidth of 0.2 Hz. This entails that for any fault frequency the magnitude of the power spectral density seeps out on bordering frequency bins at + 0.2 Hz from the faulty frequency.

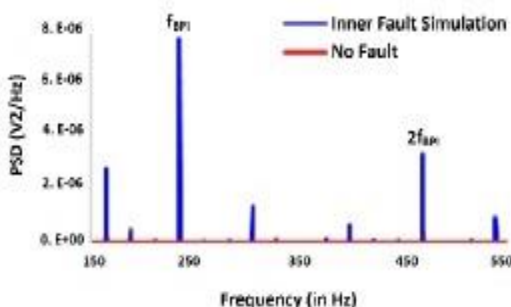

Fig.5(a). Frequency Spectrum of Electromagnetic Torque of Dynamic Simulation Motor with Bearing Fault

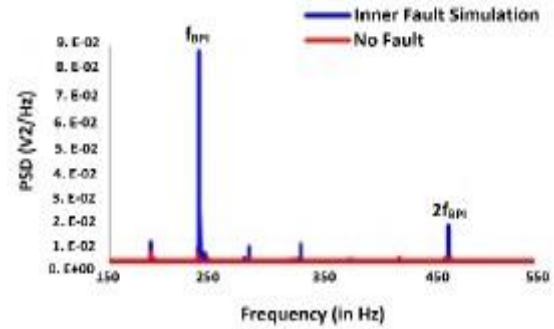

Fig.5(b). Characteristic Frequencies in the Spectral Analysis of Vibration of Induction Motor with Inner Race Bearing Fault

### 3.2.1. Using Park Vector Approach and Complex Wavelets

The impact of stator fault on machine current can be examined through Park vector transformation approach. The locus of instantaneous spatial vector sum of the three phase stator currents forms the basis for Park’s vector. Generally, a three phase induction motor does not involve the connection to the neutral. It only involves the connection with the three phase mains. Hence, the mains current has no homopolar current. A two dimensional representation of three phase current of induction motor can be achieved using Park’s Transform. As a function of mains phase variable ( $I_a, I_b, I_c$ ), the Park’s vector components ( $I_D, I_Q$ ) are:

$$I_D = \sqrt{\frac{2}{3}}I_a - \frac{1}{\sqrt{6}}I_b - \frac{1}{\sqrt{6}}I_c$$

$$I_Q = \frac{1}{\sqrt{2}}I_b - \frac{1}{\sqrt{2}}I_c$$

This maps a circle. This circle has its centre at the origin (0, 0) of the coordinates. This locus is distorted by stator winding faults and thus provides easy fault diagnosis. Besides making analysis and calculations easier, Park’s Transform scores over traditional methods in terms of being economical, especially for small and medium-sized motors. Also it can diagnose the faults without requiring access to motor. In order to investigate the proposed technique, a 3 phase, 4 pole induction motor model with 36 stator slots and 55 turns per slot is simulated. The 3 phase supply currents are measured and Park vector currents are calculated using Park’s Transform. Considering no fault in the stator, the motor current’s Park vector is presented in Fig. 6(a). In case of a stator fault, the motor current’s Park vector is shown in Fig. 6(b). The current Park’s vector for a healthy motor corresponds to a circle whereas for a faulty one, the shape distorts to an ellipse depending upon the amount of fault level. Simulation and experimental results are finally analyzed using complex wavelets.



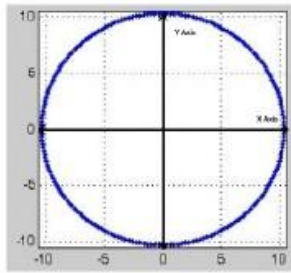

Fig.6(a). Motor Current's Park's Vector Representation at Healthy Case

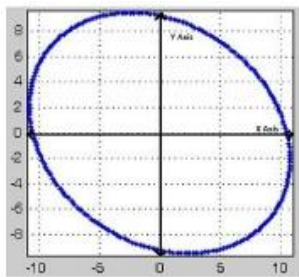

Fig.6(b). Motor Current's Park's Vector Representation at Faulty Case

### 3.3. Detection of Rotor Faults and Eccentricity

#### 3.3.1. Motor Current Signature Analysis (MCSA)

Current harmonics in the stator current are analyzed by MCSA [53-59]. These harmonics are caused by new rotating flux components on account of a fault. It needs only one current sensor and is based on signal processing techniques like FFT. The equipment set up for measuring motor current is shown in Fig. 7. Data acquisition is achieved by performing FFT on the stator Current. The data obtained after FFT is normalized as a function of the first harmonic amplitude is then analyzed. Fig. 8(a) and Fig. 8(b) illustrates FFT with initial condition of rotor bars and with 3 broken rotor bars respectively.

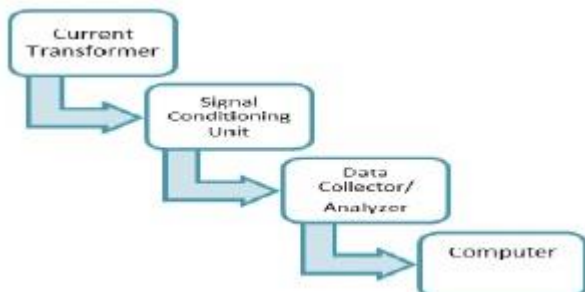

Fig.7 Set-Up for Measuring Motor Current

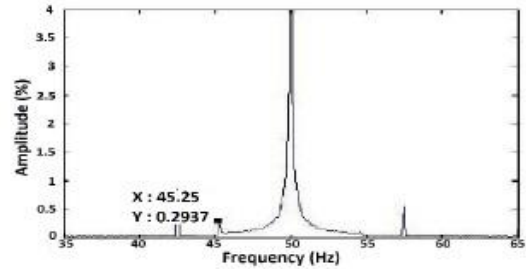

Fig. 8(a) FFT with initial condition for broken bars

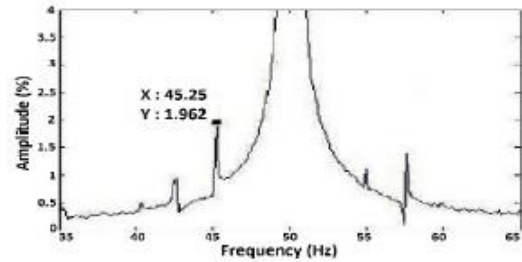

Fig. 8 ( b) FFT with 3 broken bars

Table 2 indicates the percentage amplitude for harmonics with different number of broken rotor bars. Evidently, the harmonic contents increase with increase in fault level i.e. rise of count of broken rotor bars.

Frequency(Hz)	Amplitude%	No. of Broken Bars
45.25	0.2937	0
45.25	1.028	1
45.25	1.83	2
45.25	1.962	3

Table 2

Similarly, eccentricity also causes a change in the FFT of induction motor. Fig. 9(a) and Fig. 9(b) illustrate the FFT with initial condition of rotor bars and with 87.3% eccentricity respectively.

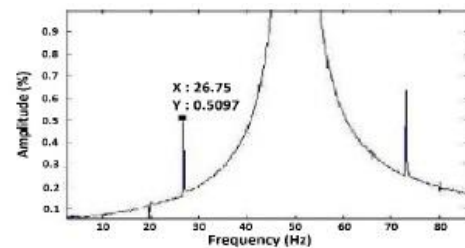

Fig. 9 (a) FFT with initial condition of Rotor's eccentricity

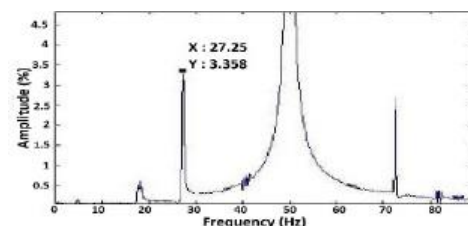

Fig. 9 (b) FFT with 87.3% of Rotor's eccentricity

Markedly, the harmonic contents increase with increase in fault level i.e. increase of eccentricity.

Eccentricity (%)	Amplitude%
0	0.39
44.5	1.96
87.3	4.94

Table 3

### 3.3.2. Intelligent Techniques

Several Intelligent techniques like Fuzzy logic systems, Artificial Neural Networks, Neuro-Fuzzy Systems etc. have been elaborately discussed for induction motor condition monitoring. Usually, any Artificial Intelligence (AI) based diagnostic technique has three prime steps- i) Signature extraction ii) Fault detection and iii) Fault severity estimation. In Fig. 10, a schematic of Neural Networks for condition monitoring of an induction motor is presented.

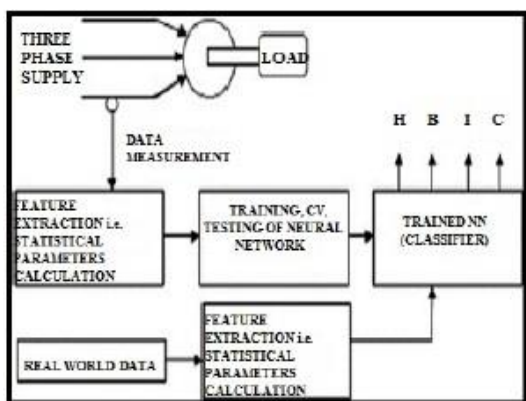

Fig. 10 Neural Network Schematic for Condition Monitoring of Induction Motor

Apart from these techniques, some other methods for the incipient fault detection of induction motor have found a mention in other literature. Table 4 presents an elaborate comparison of several fault detection techniques and the faults generally detected by them.

Fault Detection Techniques	Detected Faults
MCSA	Bearing, Rotor, Stator and Vibration Faults
Park's Transform	Bearing and Stator Faults
Artificial Neural Networks	Bearing and Rotor Faults
Wavelet Analysis	Bearing, Rotor, Stator and Vibration Faults
Finite Element Method	Rotor, Stator and Vibration Faults
Vibration Testing and Analysis	Bearing and Vibration Faults
Concordia Transform	Bearing Faults
External Magnetic Field Analysis	Rotor Faults
Multiple Reference Frames Theory	Eccentricity
Power Decomposition Technique	Stator Faults
KU Transformation Theory	Stator Faults
Zero Crossing Time Method	Stator Faults
Modal Analysis Method	Vibration Faults

Table 4. Comparison of various fault detection techniques

### 4. SCOPE OF FUTURE WORK

Expert systems can be employed for fault diagnosis using rules obtained from the connection weight of a supervised neural network and rules extracted from heuristic knowledge. This combination of Artificial Neural Networks and expert knowledge may enhance the monitoring system for diagnosis. Moreover, a data base for vibration harmonics using experimental and theoretical investigations for various sizes and design standard of three phase induction motors can be created. Through this database, a new standard for vibration can be established instead of the traditional one, which depends upon RMS velocity of vibration rather than harmonic amplitude.

### REFERENCES

[1] G.K. Singh and Sa'ad Ahmed Saleh Al Kazzaz, "Induction Machine Drive Condition Monitoring and Diagnostic Research-A Survey", Electric Power Systems Research, vol. 64, pp. 145-158, 2003.

[2] M. L. Sin, W.L. Soong and N. Ertugrul, "Induction Machine On-Line Condition Monitoring and Fault Diagnosis - A Survey", AUPEC2003, Australasian Universities Power Engineering Conference, Christchurch, New Zealand, pp. 1-6, 2003.

[3] Neelam Mehala and Ratna Dahiya "Condition Monitoring and Fault Diagnosis of Induction Motor Using Motor Current Signature Analysis", A Ph.D Thesis submitted to the Electrical Engineering Department, National Institute of Technology, Kurushetra, India, October, 2010.

[4] P. J. Tavner and J. Penman, "Condition Monitoring of Electrical Machines", Letchworth, England: Research Studies Press Ltd., 1987.

[5] Shuo Chen, "Induction Machine Broken Rotor Bar Diagnostics Using Prony Analysis", A Ph.D Thesis submitted to the School of Electrical and Electronic Engineering of the University of Adelaide, April 2008.