

Design and Fabrication of an All-Terrain Vehicle

Rishi Govind T.S¹, Noyal Thomson², Miswaramjind³, Rinto Thomas⁴, Sreyas.k⁵, Vysakh.V⁶

¹Assistant Professor, Dept. Of Mechanical Engineering, IES College of Engineering, Thrissur, Kerala, India 680551

^{2,3,4,5,6} Students, Dept. Of Mechanical Engineering, IES College of Engineering, Thrissur, Kerala, India 680551

Abstract - It is an experimental project to design and fabricate a Quad bike that can propagate along almost all terrains. It is simply called an All Terrain Vehicle. As the name implies, it is designed to handle a wider variety of terrain than most other vehicles. Although it is a street-legal vehicle in some countries, it is not street-legal within most states and provinces of Australia, the United States or Canada. The actual ATV is designed from a two-wheeler. The rider sits on and operates these vehicles like a motorcycle, but the extra wheels give more stability at slower speeds.

1. INTRODUCTION

An all-terrain vehicle(ATV), is also known as a quad, quad bike or four wheeler, is defined by the American National Standards Institute (ANSI) as a vehicle that travels on low pressure tires, with a seat that is straddled by the operator, along with handle bars for steering controls. As the name implies, it is designed to handle a wide variety of terrain than most other vehicles. Although it is street legal vehicles in some countries, it is not street legal within most states and provinces of Australia, the United States, Canada or the United Kingdom. In the UK a recent variant class of ATV is now road-legal, but there are few models available in this class. By the current ANSI definition, ATVs are intended for use by a single operator, although some companies have developed ATVs intended for use by the operator and one passenger. These ATVs are referred to in this notice as tandem ATVs. The rider sits on and operates these vehicles like a motorcycle, but the extra wheels give more stability at slower speeds. Although typically equipped with three or four wheels, six-wheel models exist for specialized applications. Engine sizes of ATVs currently for sale in United States, (as of 2008 products), range from 49 to 1000cc (3 to 61 cu in).The course of mechanical engineering is a perfect mix of all kind of knowledge including automobile engineering.

1.1 Objectives

The objective of this project is to design and fabricate a quad bike. After thorough studies, a Quad bike has been designed and fabricated and all the necessary tests have been performed to ensure its reliability in off road riding. Based on the results of these tests it has been proved that the design of this vehicle satisfies its use. Even though it is not an innovative idea, this is rarely exhibited project in India. The main difference of this Quad bike from the conventional ATVs is that, it is actually designed from a two wheeler. The main difficulty we faced during the designing was to transform a two wheeler into four wheeler.

1.2 Design Consideration

Main body consists of

Front structure

Chassis

Rear axle

Designing a body means the development of structure with links and joints. While designing the main body some care is to be taken to make it a balance structure and it should take all the loads. No places or joints should exist with concentrated loads. The loads acting in the vehicles can be broadly classified into two, namely loads acting when the bike is idle and the impacts which could occur while riding. All the loads, when idle as well as moving, are acting on the chassis or the structure. So the structure should be made in rugged fashion to entertain all these expected and unexpected loads. Care should be taken while designing each member of frame. Considerations for force and stresses have got its relevance in the front structure design. The major loads acting on any member are,

Weight of the engine and its accessories

Weight of the structure itself

Bending loads

Tilting loads

Tension or compression

Twisting moment

2. CALCULATIONS

The selection of number of linkages was done using the formulae; $n=2j-3$,

Where,

n =number of joints

j = number of linkages

$n=2j-3$,

When $j=3$,

$n= (2*3)-3=3$

Since $3=3$, the design is satisfied.

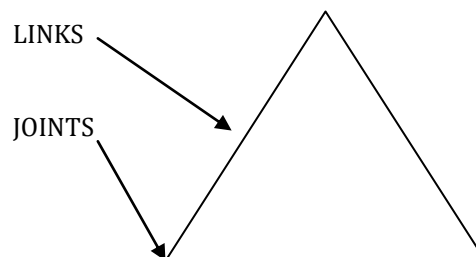

Fig -1: Links and Joints

3. MAIN BODY

Main body consists of a front structure, steering mechanism, suspension and front wheels.

3.1 Front Structure

The front structure of a quad bike is a three dimensional truss with each of its member having a role to support loads. The frame is to be welded into the bike chassis to form a rigid structure. The designing should start from the two dimensional frame at the bottom. The width of the 2D frame is set as the engine width as shown. The next consideration is the overall size of the vehicle. As the width planned is 100 cm and by considering the width of wheels, the length of the link shown in the front structure are designed. Steering stem angle is to be remained unchanged so that wheel to wheel axis should be kept that same distance with virtual stem as in the original bike. And after design no part is to be protruded out from the wheel front. All these are kept in mind while seating the dimension to each link. To get directional stability and steering control there should be a positive caster. So the lower arm and upper arm are to be tilted while fixing. To achieve this, from the rectangular closed structure a trapezium shaped form is attached from which lower arms are to be connected. In order to place upper arms in the same vertical plane parallel to previous a triangular form is to be there with an inclination equal to that of knuckle. To share the compressive load with lower and upper arms, additional link rose are given so that arms would have to take tensile loads only. Unbalanced forces are avoided by connecting all the links in triangular form. Now the steering stem length is to be set to get the final height as that of bike. In addition to the strengthening rods attached, a provision for fixing two independent suspensions is also provided. As the fork is to be cut from the original steering stem there is a probability of tilting and the torque transmission will be difficult. A separate V link is provided with the steering to prevent the tilting. The work started with forming the base frame which is the bottommost frame in the bike. The frame is welded as per the design. The welding is done such that all the forces are concentrated to a point and the member should withstand all these forces thereby avoiding rupture. Two other members are also provided for reinforcement and the member is welded to base frame. Lower and upper arms for both side are then welded to the reinforcing member which takes up the side forces. Upper arms are also provided with hook joint in order to connect the suspension. The welding is done by dipping the rubber seals which covers the ball joint in cold water thereby preventing overheating. If it is not practiced, the damage of rubber seals may affect the satisfactory performance of the ball joint which is to be connected to the knuckle joint. The arms are not welded to the structure instead they are connected by means of a nut and screw which allows rotation of arms along its axis and rubber washers are introduced to avert friction.

Base frame is welded to the bike chassis at the cross members. The handle rod is supported using the frame which is welded to chassis at one side and the other to the force concentrating point. During each individual joining steps the work is done by checking the geometry for misalignment with the help of spirit level indicators.

3.2 Steering mechanism

The forks which were used to connect the wheel, has been removed. The steering rod is pushed into the handle rod and is supported to the handle bar with the help of a V member fastened by nuts and bolts at either side. This avoids wavering of steering the steering rod. The steering is given to the wheels through knuckles by means of a nut and bolt locking arrangement with rubber seals. The steering rod is actually a T-shaped one in which the perpendicular members are joined via nut and bolt arrangement protected by rubber rings. In the fabricated project the turning radius of the steering is found to be 2m.

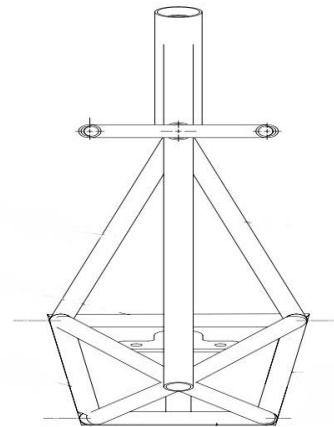

Fig -2: Front View Design of Steering Mechanism

3.3 Suspension

Suspension is the term given to the system of springs, shock absorbers and linkages that connects a vehicle to its wheels. Suspension systems serve a dual purpose----contributing to the car's road holding/handling and braking for good active safety and driving pleasure, and keeping vehicle occupants comfortable and reasonably well isolated from road noise, bumps and vibrations etc. These goals are generally at odds, so the turning of suspension to keep the road wheel in contact with road surface as much as possible, because all the forces acting on the vehicle do so through the contact patches of the tires. The suspension also protects the vehicle itself and any cargo or luggage from damage and wear.



Fig -3: Suspension

3.4 Front wheels and suspension

Front structure is held upright using a jack for attaching wheels and another jack hold the chassis in alignment. The wheels are connected to their corresponding knuckles by bolting it at four points. Front suspensions are then introduced. It is connected to the drilled holes in the cross member at the top and to the upper arm at the bottom using hooks and bolts. If the engine gives the heart to the body of an automobile then the condition of heart is controlled by the suspension system employed. Choosing the right type of suspension was another obstruction in achieving our goal. We decided to go with the independent suspension for the front wheels and mono shock suspension for rear wheels. Availability of the suspension system was not a big ask for us. But the biggest difficulty that we faced in selection was to incorporate the suspension system with the design and the availability of accessories that are required for mounting. Another dilemma involved in the selection was the economic conditions. The different suspension that was available for us was Macpherson strut type in maruti800, Bajaj chetak coil spring with damper, etc. First we considered the Macpherson strut type for front wheels which required independent suspension. But the cost that involved was really high thus we have to go for another system. Then we opted for the suspension system that are economical and satisfies our design. Then we considered the mono shock suspension which required high stiffness with good damping power. The suspension is held at an angle of 60 degree from the base.

3.5 Mono-Shock

On a motorcycle with a mono shock rear suspension, there is only one shock that connects the rear swing arm to the motorcycle's frame. Typically this lone shock absorber is in front of rear wheel, and uses a linkage to connect to the swing arm. Mono shock eliminates torque to the swing arm and provides more consistent handling and braking. They are also easier to adjust, since there is only one shock absorber to adjust, and there is no worry of matching two shocks. Also the linkages used to connect the shock to the swing arm are frequently designed to give a rising rate of damping for the rear. Mono shock is fixed at an angle of 70 degree from the base.



Fig -4: Mono-Shock

3.6 Pre-load adjustment

The pre-load on a rear shock absorber is typically adjusted via a threaded or notched collar on the shock. As the collar is rotated, the coil-over spring is compressed more or less. The more the spring is compressed, the higher the pre-load, and vice-versa. Some shock absorbers, known as air assist shock absorbers, allow adjustment of pre-load by changing the air pressure inside the shock. A valve on the shock absorber allows air to be introduced or released from shock. More air pressure gives more pre-load and vice versa.

3.7 Damping adjustment

Stock rear shocks typically offer no damping adjustments, or a single adjustment for both compression and rebound damping. This adjustment is usually made by a dial at the very top or very bottom of the shock. The dial selects one of a few different orifice sizes for the damping fluid flow path. The larger the orifice, the less the damping, and vice versa. In automobiles, a double wishbone suspension is an independent suspension design using two wishbone shaped arm to locate the wheel. Each wishbone or arm has two mounting point to the chassis and one joint at the knuckle. The shock absorber and the coil spring mount to the wishbones to control vertical movement.

4. REAR AXLE

The rear axle is made out of a solid shaft. It is then drilled at four points. The shaft is turned at lathe to have a force fit (interference) at bearing location. Flanges provide attachment to the sprocket and disc. Sprockets and disc are then fastened to flanges via nut and bolt. The bearings are force fitted into the housing which has been welded into clamps required to finally attach to the chassis. Stiffer are welded at either ends of the axle to attach the wheels through bolting. The rear axle here we used is of 800mm length and 1 inch diameter.

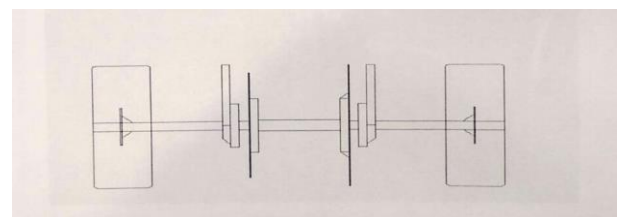

Fig -5: Rear axle

5. BRAKES

5.1 Considerations taken

Braking is to be done only at the rear wheels. Braking torque should not fail the axle. The rear axle can be equipped with either disc or drum brakes. Drum brakes have lesser braking speed than disc type. As it is only provided at the rear end, disc brake is opted. The brake can be applied either by wire mechanism or hydraulic. The lever can be used either by hand as in front brakes in bikes or by right foot as in rear brakes in bikes. The wire type requires greater effort than the hydraulic type, so hydraulic type is opted. The right foot braking lever is available with hydraulic type. The disc and caliper is selected as per the availability basis.

5.2 Basic construction of brake system

Brake system consists of a disc, caliper, master cylinder and hoses. Caliper is mounted at one point of the clamp. Brake pedal and the master cylinder are attached to the front structure. The master cylinder consists of one pistons whose outputs are joined together to obtain maximum pressure for braking. Hoses are used to join these units.

6. LUBRICATION

Most small petrol two-stroke engines cannot be lubricated by oil contained in their crankcase and sump, since the crankcase is already being used to pump air-fuel mixture into the cylinder. Traditionally the moving parts (both rotating crankshaft and sliding piston) were lubricated by a pre-mixed fuel-oil mixture (at a ratio between 16:1 and 50:1). As late as the 1960s petrol stations would often have a separate pump that would deliver such a pre-mix fuel to motorcycles. Even then, in many cases the rider would carry a bottle of his own two-stroke oil. Taking care to close the fuel tap first, he or she would meter in a little oil (using the cap of the bottle) and then put in the petrol, this action mixing the two liquids. Modern two stroke engines pump lubrication from a separate tank of oil. This is still a total loss system with the oil being burnt the same as in the older system, but at a lower and more economical rate. It is also cleaner, reducing the problem of oil-fouling of the spark plugs and coke formation in the cylinder and the exhaust. Almost the only motors still using the pre-mix are hand held two stroke devices such as chainsaws (which must operate in any attitude) and the majority of model engines. All two-stroke engines running on a petrol mix will suffer oil-starvation if forced to rotate at speed with the throttle closed, e.g. motorcycles descending long hills and perhaps when decelerating gradually from high speed by changing down through the gears. Two stroke cars were in particular danger and were usually fitted with freewheel mechanism in the power train, allowing the engine to idle when the throttle was closed, requiring the use of brakes in all slowing down situations. Large two stroke engines, including diesels, normally use a sump lubrication system similar to four-stroke engines. The cylinder must be still pressurized but

this is not done from the crankcase but by a pump or supercharger.

7. FABRICATION PROCESS

Fabrication is the process by which the concepts and planning turns to a tangible entity. The fabrication incorporates all the design considerations, parts availability and economic feasibility at utmost care. The main notion in the fabrication is to superimpose with our design procedures. Design procedures raised many new challenges for us. The major stumbling block in the project while doing the fabrication was the availability of parts with minimum capital for optimum performance. And we have come up with new solution which would cope with our design, with minimum investment. Various machining process like turning, drilling, boring, milling etc along with joining process like welding and tightening using fasteners were involved in fabrication. We have the chassis which is the platform to build the structure. The front frame and the rear axle are attached to the purchased chassis. The whole fabrication can be considered as an extension work done to incorporate the four wheels. It is more likely to consider the entire procedure as a conversion of a two wheeler or four wheeler. Starting so, the process may seem easier, but the actual problem occurs in manufacturing a vehicle is in its alignment. So alignment is checked while adding each component to the core structure.

8. TWO STROKE ENGINE

A Two-stroke engine is an internal combustion engine that completes the process cycle in one revolution of the crankshaft (an upstroke and down stroke of the piston, compared to twice that number of a four-stroke engine). This is accomplished by using the beginning of the compression stroke and the end of the combustion stroke to perform simultaneously the intake and exhaust functions. In this way two-stroke engines often provide strikingly high specific power, at least in a narrow range of rotation speeds. The functions of some or all of the valves required by a four-stroke engine are usually served in a two stroke engine by ports that are opened and closed by the motion of the pistons, greatly reducing the number of moving parts. Gasoline (spark ignition) versions are particularly useful in lightweight (portable) applications such as chainsaws and the concept is also used in diesel compression ignition engines in large and non-weight sensitive applications such as ships and locomotives. Invention of two stroke cycle is attributed to Scottish engineer Dugald Clerk who in 1881 patented his design, his engine having a separate charging cylinder. The crankcase scavenged engine, employing the area below the piston as a charging pump, is generally credited to Englishman Joseph Day (and Frederick Cock for the piston controlled inlet port).

Two-stroke engines do not have valves, which simplifies their construction and lowers their weight.

Two-stroke engines fire once every revolution, while four stroke engines fire once every other revolution. This gives two stroke engines a significant power boost.

Two stroke engines can work in any orientation, which can be important in something like a chainsaw. A standard four stroke engine may have problems with the oil flow unless it is upright, and solving this problem can add complexity to the engine.

These advantages make two stroke engines lighter, simpler and less expensive to manufacture. Two-stroke engines also have the potential to pack about twice the power into the same space because there twice as many power strokes per revolution. The combination of light weight and twice the power gives two stroke engines a great power-to-weight ratio compared to many four-stroke engine designs.

9. CONCLUSIONS

After thorough studies, a Quad bike has been designed and fabricated and all the necessary tests have been performed to ensure its reliability in off road riding. Based on the results of these tests it has proved that the design of this vehicle satisfies its use. Even though it is not an innovative idea, this is rarely exhibited project in India. The main difference of this Quad bike from conventional ATVs is that, it is actually designed from a two wheeler. The main difficulty we faced during the designing was to transform a two wheeler into a four wheeler. As it is not an ordinary vehicle it has to withstand heavy unbalanced forces during its off road riding. Thus we have provided triangular linkages for equal load transmissions.

REFERENCES

- Designing of All Terrain Vehicle (ATV) by Deep Shrivastava, International Journal of Scientific and Research Publications, Volume 4, Issue 12, December 2014
- Design & Manufacturing of All Terrain Vehicle (ATV)- Selection, Modification, Static & Dynamic Analysis of ATV Vehicle, Upendra S. Gupta, Sumit Chandak, Devashish Dixit, International Journal of Engineering Trends and Technology (IJETT) – Volume 20 Number 3 – Feb 2015
- Quad Bike Design And Simulation: A Pre-Manufacturing Methodology, Srijan Manish, Jitendra Kumar Rajak, Vishnu Kant Tiwari, Rakesh, Volume 5, Issue 6, June (2014), pp. 68-76